

# Loading Guidelines

Code of practice for the loading and securing  
of goods on railway wagons

Volume 2

Goods

Version 01/04/2026

10<sup>th</sup> edition



INTERNATIONAL UNION  
OF RAILWAYS

<b>Release history</b>	
<b>Version</b>	<b>Changes/Numbers</b>
01/04/2017	Complete revision
01/04/2018	Instructions for the use of the UIC Loading Guidelines in volume 2, 2.2.1, 2.2.2, 2.6, 4.1.3, 4.1.4, 6.2, 9.0, 9.2, 9.4, 20.2, 100.2, 100.3
01/04/2019	0.10, 1.5.1, 1.5.2, 1.8.3, 7.1, 9.4 +(Footnote “Minimum breaking strength in tangent traction” has been supplemented)
01/04/2020	0.8, 1.5.3, 4.1.4, 7.1, 7.2, 9.0 Table 4 +(numbering by letters in chapter 9)
01/04/2021	0.1, 0.2, 0.10, 1.3.2, 1.5.2, 1.5.3, 1.6.1, 1.6.2, 1.8.2, 1.8.3, 4.1.4, 9.0, 9.1, 9.1.4, 9.2, 9.4, 100.2, 100.3
01/04/2022	Instructions for the use of the UIC Loading Guidelines in volume 2, 0.7, 1.2.6, 1.4.6, 9.0, 9.0.1, 9.1, 9.1.3, 9.2
01/04/2023	Instructions for the use of the UIC Loading Guidelines in volume 2, 1.2.4, 1.4.7, 1.6.1, 1.6.2, 1.10.6, 7.3, 7.7, 9.0, 9.1, 9.1.1, 9.1.2, 9.1.3, 9.1.4, 9.2, 9.4, 100.2
01/04/2024	0.1, 0.7, 1.2.6, 1.8.1, 1.8.3, 6.3, 9.1, 9.1.2, 9.1.3, 9.1.4, 9.2
01/04/2025	1.6.3, 1.6.6, 1.8.1, 1.8.2, 1.8.3, 1.8.4, 1.8.5, 7.5, 7.7 (repealed), 9.2, 100.2
01/04/2026	1.8.3, 1.8.5, 9.0, 9.0.1, 9.2

### Warning

Any copies, reproductions or distributions, in full or partial, by any means, including electronic means, for use other than private and individual, are prohibited without the express consent of the International Union of Railways. The same shall apply to translations, adaptations or transformations, arrangements or reproduction by any technique or process whatsoever. “Analyses and short quotations justified by the critical, polemical, educational, scientific or informatory nature of the work in which they are incorporated” (Articles L 122-4 and L122-5 of the French Intellectual Property Code) are permitted on condition that the name of the author and the source are clearly stated.

© Copyright International Union of Railways (UIC) - Paris, 2026  
 Published by the International Union of Railways (UIC)  
 16 rue Jean Rey, 75015 Paris - France  
 Registration of copyright January 2026  
 ISBN **978-2-7461-3593-2**

## **Instructions for the use of the UIC Loading Guidelines in volume 2**

The loading Guidelines are designed to guarantee operating safety and ensure damage-free conveyance of the goods in question.

The loading Guidelines contain all the necessary measures for the loading and securing of goods.

The loading Guidelines describe the loading condition and securing during the shipment procedure.

The loading Guidelines correspond, in the main, to the principles set out in volume 1 or have been developed based on experience in practice. They may contain either more or less stringent requirements for the securing loads. Used in conjunction with the indications on the loading gauge, they thus provide comprehensive instructions for the proper loading of goods. As such, for the specific cases covered by these guidelines, reference to the regulations in volume 1 is no longer necessary in principle. The indications contained in the Loading Guidelines are to be considered as minimum requirements. If necessary, they must be increased or extended after checking by the shipper/consignor.

Alternative loading and securing methods are permitted, providing the provisions of volume 1 are complied with.

## Table of content

Instructions for the use of the UIC Loading Guidelines in volume 2

### Chapter 0: Information Sheets

- 0.1 Load of wagons
- 0.2 Maximum dimensions of loads
- 0.3 Covering of loads
- 0.4 Bulk goods
- 0.6 Single-use bindings for securing the load
- 0.7 Indirect fastenings
- 0.8 Friction and coefficients of friction
- 0.9 Long load units on two carrier wagons with swivelling / sliding-swivelling bolsters
- 0.10 Wooden load carriers/pallet

### Chapter 1: Metal

- 1.2.2 Steel sheet in packages on bound-in timbers placed crossways, able to slide
- 1.2.3 Steel sheet in packages on timbers placed lengthways, able to slide
- 1.2.4 Heavy plates without timbers (ungreased)
- 1.2.5 Heavy plates (ungreased and particularly wide)
- 1.2.6 Heavy plates (ungreased)
- 1.3.1 Coiled sheet (greased or ungreased)
- 1.3.2 Ungreased hot-rolled coiled sheet
- 1.4.1 Steel pipes in tiers, diameter greater than 65 cm (26")
- 1.4.2 Steel pipes in tiers, diameter of over 40 cm up to 65 cm (16" - 26")
- 1.4.3 Steel pipes in tiers, diameter of over 25 and up to 40 cm (10" - 16")
- 1.4.4 Steel pipes in dovetailed stacks, resting on the stanchions
- 1.4.5 Steel pipes in dovetailed stacks, laterally scotched
- 1.4.6 Steel pipes, dovetailed on special wagons
- 1.4.7 Steel tubes/pipes, bars and polygonal sections bound into bundles
- 1.5.1 Wheelsets
- 1.5.2 Wheelset rubber support pads
- 1.5.3 One or several bogies with wheelsets (rubber support pads)
- 1.6.1 Sections (ungreased)
- 1.6.2 Sections (ungreased) loaded in staggered formation
- 1.6.3 Steel bars and other sections in packages (ungreased)
- 1.6.4 Steel billets
- 1.6.5 Steel rod for reinforced concrete (up to 36 m long)
- 1.6.6 Sheet piling sections (ungreased)
- 1.6.9 Steel slab
- 1.7.1 Steel rods loaded onto wagons
- 1.8.1 Rails loaded on one wagon
- 1.8.2 Rails loaded on two wagons
- 1.8.3 Rails loaded on more than two wagons, up to 150 m in length
- 1.8.4 Rails loaded on two wagons, with spacers
- 1.8.5 Rails (loaded on several flat wagons)
- 1.8.6 Rails on one wagon, loaded in staggered formation
- 1.9.1 Aluminium slabs
- 1.10.1 Metal trellis-work
- 1.10.2 Wire netting in rolls
- 1.10.3 Wire netting in rolls and in bundles
- 1.10.4 Coils of wire rod (all diameters) loaded gunshot
- 1.10.5 Coils of wire rod loaded on the roll
- 1.10.6 Coils of wire rod loaded on the roll in two tiers
- 1.11.1 Scrap
- 1.11.2 Heavy scrap

### Chapter 2: Wood

- 2.1 Rough logs
- 2.2.1 Square-sawn rough timber in packages
- 2.2.2 Square-sawn smooth timber (planed, precision-sawn) in packages
- 2.4 Wood in bundles
- 2.5 Wooden sleepers (in packages)
- 2.6 Wooden sleepers, impregnated (in packages)
- 2.7 Wooden sleepers (untied)
- 2.8 Wood chippings
- 2.9 Plywood slabs, hardboard
- 2.10 Glue-laminated timber (GL) or solid construction timber (SCT) in packages

### Chapter 3: Agriculture

- 3.1 Peat and similar substances in compressed bales

### Chapter 4: Paper

- 4.1.1 Rolls of paper loaded on the roll ("eye-to-side")
- 4.1.2 Rolls of paper loaded "gunshot" (eye-to-end)
- 4.1.3 Rolls of paper loaded upright (eye-to-sky)
- 4.1.4 Rolls of paper and wood pulp loaded upright ("eye-to-sky")
- 4.1.5 Rolls of paper
- 4.1.6 Rolls of paper loaded "gunshot" (eye-to-end)
- 4.2.1 Wood pulp in bales (individual bales)
- 4.2.2 Wood pulp in bales (in units)

### Chapter 5: Reserved

### Chapter 6: Stone and construction materials

- 6.1.1 Blocks of stone (worked)
- 6.1.2 Blocks of stone (unworked)
- 6.2 Stone and concrete slabs on steel trestles (sliding method of loading may be used, except for goods loaded in intermodal loading units (ILUs))
- 6.3 Concrete sleepers loaded crossways

### Chapter 7: Vehicles and machinery

- 7.1 Vehicles and machinery on wheels or caterpillar tracks, secured with scotches
- 7.2 Vehicles and machinery on wheels or caterpillar tracks, secured with fastenings
- 7.3 Wheeled vehicles
- 7.4 Wheeled vehicles
- 7.5 Vehicles with tyres, weighing no more than 2800 kg
- 7.6 Vehicles with tyres weighing no more than 2200 kg, secured with a single scotch and forwarded by block trains
- 7.7 Vehicles with tyres weighing up to 2800 kg with electric traction

### Chapter 8: Boats

- 8.1 Boats weighing up to 500 kg
- 8.2 Boats weighing over 500 kg
- 8.3 Boats on trailers

### Chapter 9: Combined transport load units

- 9.0 Combined transport - General
- 9.0.1 Securing of goods inside Intermodal Loading Units (ILUs)
- 9.1 Swap bodies (SBs)
- 9.1.1 Swap bodies dedicated to certain carrier wagons
- 9.1.2 Special swap bodies
- 9.1.3 Flats
- 9.1.4 Heavy-duty swap bodies
- 9.2 Containers
- 9.3 Demountable bodies (DBs)
- 9.4 Semi-trailers (STs)
- 9.4.1 Semi-trailers Novatrans system ("N")

### Chapter 10: Barrels

- 10.1 Barrels
- 10.2 Barrels in wagons with sliding walls

### Chapter 11: Palletized load units

- 11.1 Formation of palletised load units
- 20.1 Cable drums, loaded "gunshot"

### Chapter 100/200: Miscellaneous

- 100.1 Goods in wagons with sliding doors and lockable partition walls
- 100.2 Wagons with strengthened sliding walls without code letters ii
- 100.3 Wagons with high-strength side stanchions



## **Chapter 0: Information Sheets**



## 0.1 Load of wagons

### Loading procedure

Lines are divided into categories according to axle-load and mass per linear metre A, B1, B2, C2, C3, C4, D2, D3, D4, E4, E5, where

A = 16.0 t 1 = 5.0 t/m

B = 18.0 t 2 = 6.4 t/m

C = 20.0 t 3 = 7.2 t/m

D = 22.5 t 4 = 8.0 t/m

E = 25.0 t 5 = 8.8 t/m

Plate (example) with maximum load limits

	A	B	C2	C3	D2
S	39 t	47 t	55 t	57 t	
120	0.00 t				

- Identify the line category with the lowest load limit on the route to be taken
- Comply with the load limit indicated on the wagon for the line category

Derogation plate (example)

Higher values are permissible on certain RUs/IMs in the line categories and speeds indicated.

DB, ÖBB SBB, FS	C
100	59 t

### Distribution of loads

- The load should be distributed as uniformly as possible

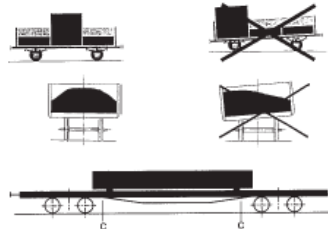

### Single loads

- Respect the relevant values lengthways along the wagon
  - load resting on the wagon floor or at least four timbers,
  - load resting on two timbers



across the wagon

Bearing width of individual load

Examples

at least 2.0 m,  
where border of table opposite is a single line

	m	t
a - a	0   00	00
b - b	0   00	00
c - c	0   00	00

at least 1.2 m,  
where border is a double line.

	m	t
a - a	0   00	00
b - b	0   00	00
c - c	0   00	00

When the symbol " ——— " is used alone, the values are also valid for loading on two timbers.

Goods which could damage wagon floors because of their small bearing surfaces, shape or weight are to be placed on timbers. Such timbers shall be required when the loads exerted on the wagon floor exceed:

- 10 kg/cm<sup>2</sup> for wagons bearing the UIC sign,
- 5 kg/cm<sup>2</sup> for other wagons.

For road vehicles loaded onto low-loader wagons a load of 5000 kg per wheel is permissible without timbers.

The maximum permissible floor loadings exerted by conveyor vehicles shall be:

- 3000 kg/wheel for wagon
- 2760 kg/wheel for large containers, where a minimum distance of 760 mm between two such surfaces shall be mandatory

## 0.1

### Axle/bogie- and wheel-loads distribution

- Ratio between the wheel loads of a single axle across the wagon: max. 1.25:1. If the centre of gravity of the load is off-centre, the ratio between the wheel loads is to be calculated in accordance with volume 1, point 3.3.
- Ratio of axle-load/bogie load lengthways along the wagon
  - on an axle wagon max. 2:1,
  - on a bogie wagon max. 3:1.

The permissible axle-load must not be exceeded.

## 0.2 Maximum dimensions of loads

### Width and height

- Determine the smallest loading gauge on the route in question (see Loading guidelines, volume 1, tables 1).

#### Loading gauges

Example

Exemple

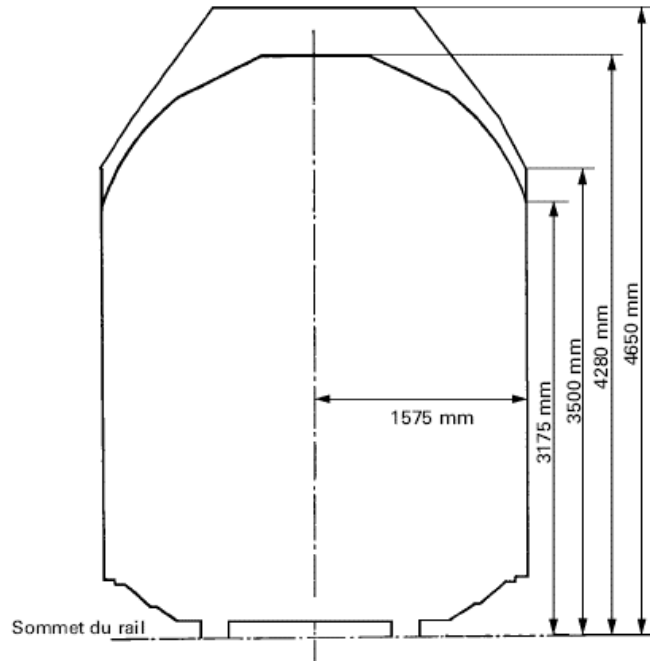

- Calculate the reduction of the loading width due to vehicle wheelbase (distance between axles) and overhang of the load in curves (see Loading guidelines, volume 1, tables 2).

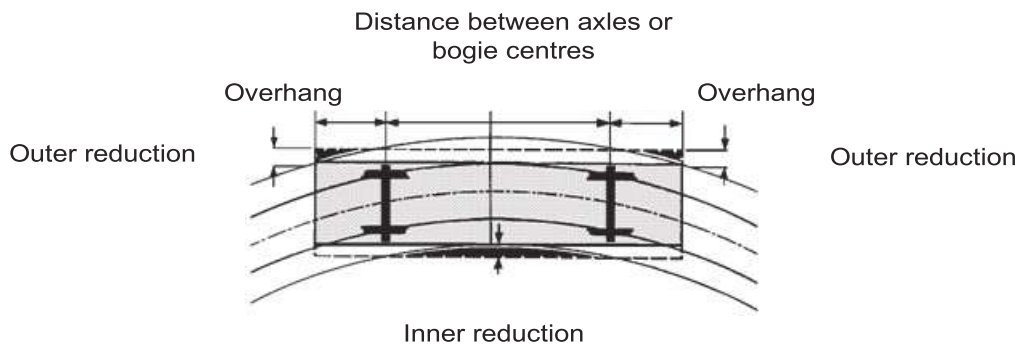

Check that the loading gauge is respected on horizontal, straight track; measurements to be taken above rail level.

## 0.2

### Length of load

- Ensure that the load length marked on the wagon is observed, e.g.:  $\overbrace{\hspace{2cm}}^{12\text{ m}}$
- The load may extend beyond the headstock by:
  - ③ • 21 cm maximum up to a height of 2 m above rail level and
  - ④ • 41 cm maximum above a height of 2 m above rail level,

as measured from the buffer fastening plane.

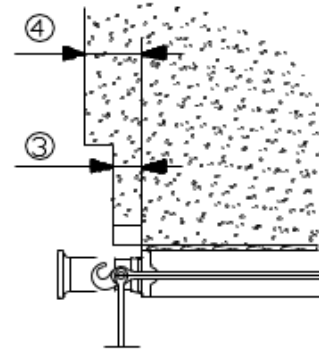

- ⑤ • with a clear space of 20 cm left over the wagon end step, measured at the level of the buffer fastenings, from the middle of the wagon end step to a height of 2 m.

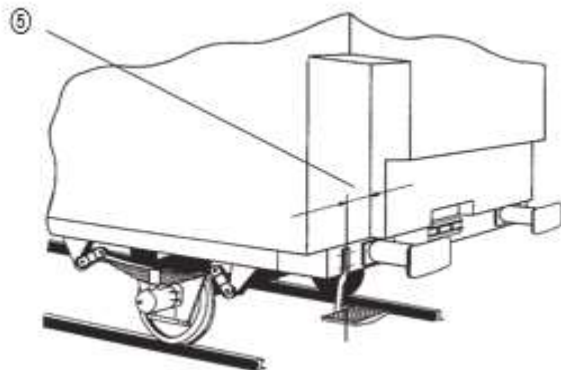

- ⑥ - there is a clearance of 20 cm measured from the draw hook on either side and above.

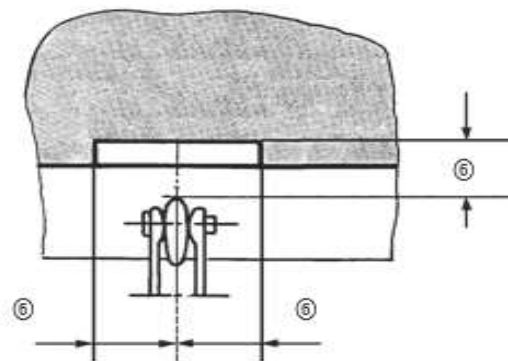

- On wagons with shock-absorbers, the surfaces marked with black and yellow stripes should also be kept free.

If the load extends beyond the prescribed limit, a buffer wagon should be inserted:

- ⑦ • vertical clearance of load above buffer wagon at least 10 cm,
- ⑧ • when the buffer wagon is loaded, there should be a longitudinal distance of at least 35 cm between the loads.

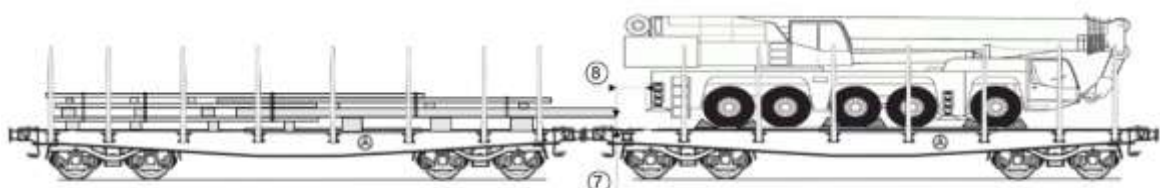

## 0.3 Covering of loads

### Goods

Goods should be covered

- for protection against the weather,
- to avoid being blown away by the wind (e.g. small-grained products such as wood chippings, gravels),
- in compliance with the RID (Regulations concerning the International Carriage of Dangerous Goods by Rail).

### Wagons

Wagons with fixed walls, stanchions or sides

### Coverings

**Sheets** (compliant with UIC Leaflet 806)

**Single-use sheets** (compliant with volume 1, point 6.1.2)

These must be:

- protected, if they rest on sharp edges,
- stretched tight such as to avoid the formation of puddles,
- arranged such that the markings (RU and number) on the sheet and the wagon remain visible,
- neither attached to moveable parts of the wagon nor nailed in place,

① stretched tight using indirect fastenings (in order to avoid flapping or ballooning)

② ○ stretched tight using non-metallic bindings tied to each eyelet and to the wagon rings or hooks with a double knot,

③ ○ the bindings are to be positioned at intervals of approx. 1 m,

④ • if several overlapping sheets are used (no overlap is permitted for single-use sheets) on the same wagon,

⑤ ○ they are to be tautly secured using oblique bindings,

⑥ ○ the bindings are to be positioned at intervals of approx. 1 m,

⑦ ○ if an eyelet is missing at the point where the sheets overlap, the third binding may be replaced by a fastening that encircles the whole sheet.

- In addition, by analogy with point ⑪, single-use sheets must be secured by means of an indirect fastening every 2 m approx.

**Mesh** (standard chicken-wire)

- mesh width: maximum 100 mm.

### Synthetic netting

- Nets made of synthetic material should have a mesh width of approx. 30 mm (longitudinal breaking strength<sup>1)</sup>: 39 daN min.; transverse breaking strength: 48 daN min.)

⑧ • The covering is to be secured approx. every 2 m,

⑨ • by at least two bindings at each end of the wagon, or in accordance with ⑫.

⑩ • All the bindings are to be tied to the net itself **or**

⑪ ○ stretched tight crossways over the net, or

⑫ ○ the net is to be stretched tight and attached tautly to the wagon hooks (hooks are present on e.g. Eaos wagons).

### Synthetic film (separate load units only)

- Shrink-fit or stretched plastic sheeting (for palletised goods, the feet of the pallets must also be enclosed in the plastic sheeting) must withstand the mechanical stresses and climatic conditions occurring during carriage by rail. If necessary, it must be ensured that the sheeting can withstand the effects of biological conditions (micro-organisms, insects, ...).

⑬ • Securing of film: approx. every 1 m.

<sup>1)</sup> Strength test to be performed on a sample of width 10 cm with 3 threads.

### 0.3

#### Securing

- non-metallic fastenings for sheets, including single-use sheets. Breaking strength<sup>2)</sup> approx. 500 daN,
- non-metallic fastenings for nets (breaking strength<sup>2)</sup> approx. 50 daN),
- chicken-wire mesh may also be secured using steel wire.

#### Attaching the fastenings

- ⑭ sheet eyelet,
- ⑮ fastening ring on wagon,
- ⑯ thread ends of fastening through fastening ring from rear,
- ⑰ tie a double knot in the ends of the fastening at the front.

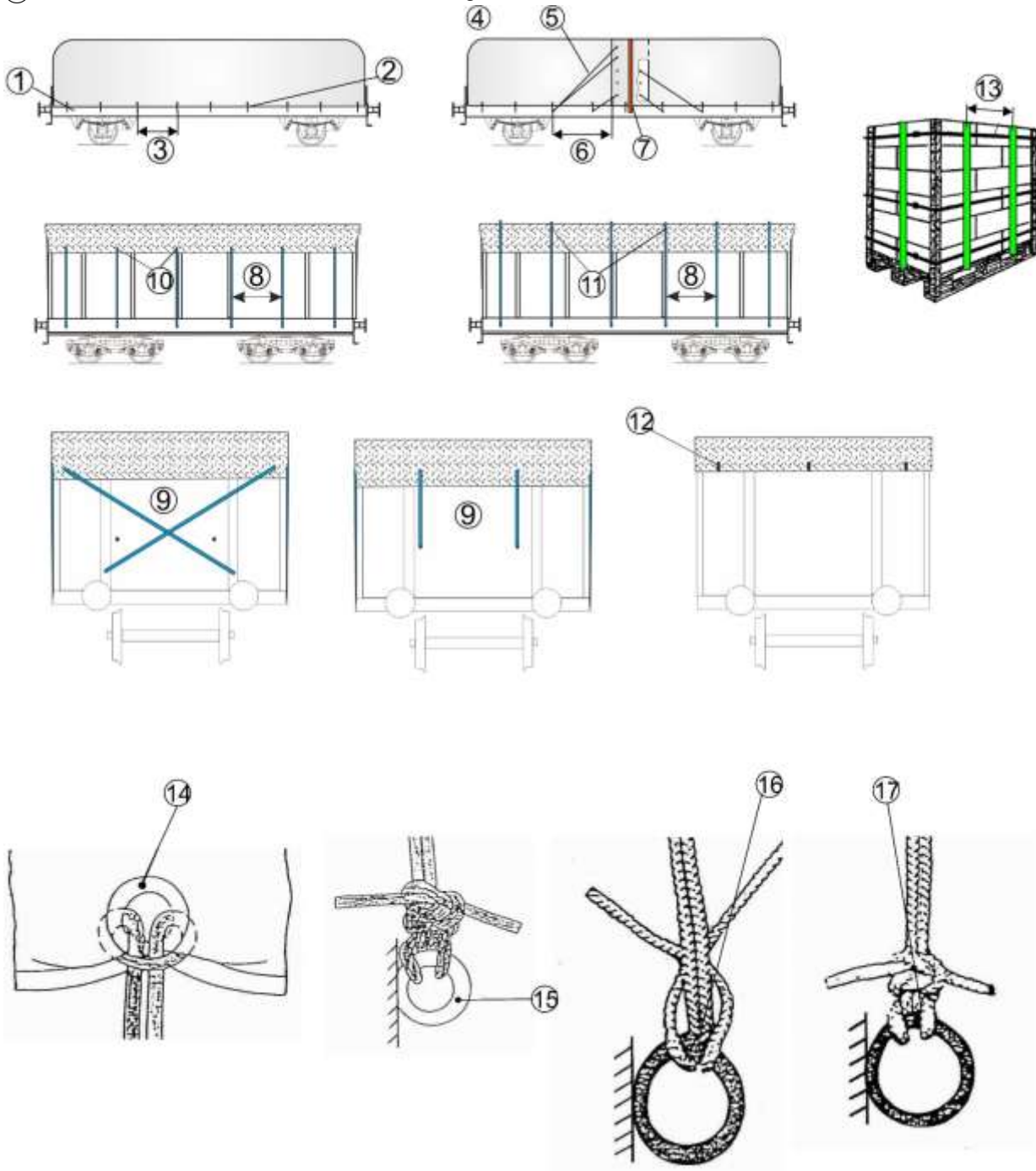

<sup>2)</sup> The minimum breaking strength (straight pull) corresponds to double the permitted tensile force (LC); this concerns only synthetic straps, woven-fabric straps and load securing straps, as well as lashing steel wire ropes and lashing chains.

## 0.4 Bulk goods

### Wagons

Wagons with fixed walls, containers, swap bodies or demountable bodies (roller units).

### Method of loading

Bulk goods should be spread evenly and compactly over the entire loading surface.

① **Goods to be loaded up to around 10 cm below the top of the side walls,**

including at the wagon centre

Goods likely to fall from the wagon:

due to shunting impacts or jolts/vibrations during transit, e.g. shredder scraps, cast iron pieces and fragments, shavings and chippings, segments of sectional iron, pipe offcuts, machine parts, round timber up to 10 cm in diameter.

② **Goods to be loaded up to approximately the top of the side walls,**

including at the centre of the wagon

Compressed scrap (briquettes), crushed or uncrushed motor cars.

③ **Goods to be fully covered**

Sections of bodywork, parings, mix of light and heavy scrap metal, bundles of household newspapers, planks and slabs up to around 15 mm thick, wood chippings.

Covering material: chicken mesh or netting made of synthetic material (check that the mesh dimensions are suited to the dimensions of the load).

Powdery goods such as fines, sand or wood shavings.

Covering material: tarpaulin

④ **To be loaded in a cone formation**

Goods **unlikely to be blown off** by wind during transit, e.g. gravels, coke, tubers, apples.

⑤ **The goods should be loaded up to around 15 cm below the top of the side walls in the vicinity of the walls.**

⑥ **Up to a height of around 50 cm**

### Covering material and fastening

See information sheet 0.3

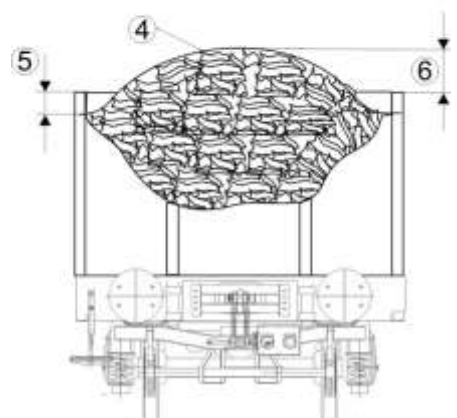
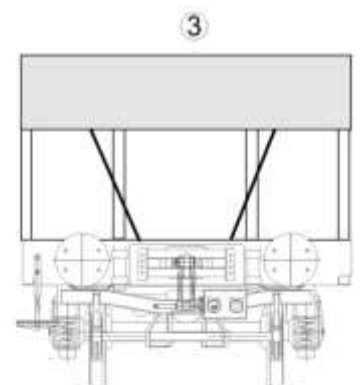
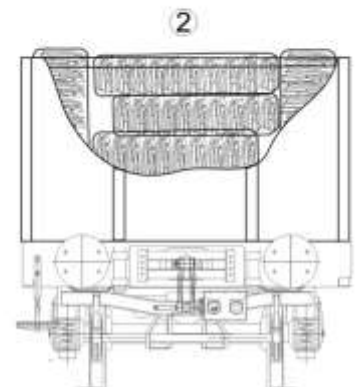
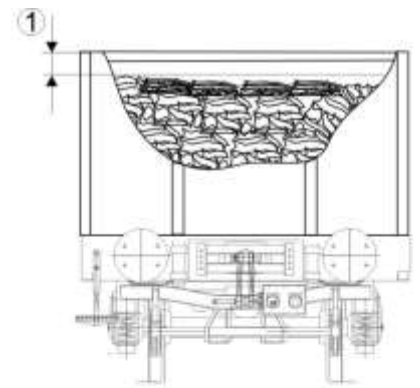



## 0.6 Single-use bindings for securing the load

### Basic principles

- Web lashing made from man-made fibres  
EN 12195-2 (current version)
- Annealed steel wire

### Characteristics

#### Web lashing made from man-made fibres

Woven textile strips (as per standard) **or**

Bindings made of parallel, high grade polyester filaments fully encased in high polymer thermoplastic coating (operational range: -25 °C to +70 °C) with locking devices, e.g. buckle(s) or slipknot(s).

The bindings, including its tensioning and securing parts, must have the following breaking strength<sup>1)</sup> as a minimum (straight pull):

- for indirect fastenings and for binding opposing stanchions: 1000 daN and,
- for direct fastenings per 1000 kg of load to be secured:

3200 daN



1000 daN

Maximum permissible extension is 7% at half the breaking strength (lashing capacity "LC").

The strap shall not slip from a buckle during a cyclic load test.

It is recommended that the manufacturer's name, the traceability code where appropriate and the breaking strength (straight pull) be indicated, including the tensioning device.

In principle, the straps used for direct fastenings must not be twisted, unless the twisting results from the position of the strap and/or the fastening points. In this case the maximum twist is 90°.

The straps used for indirect fastenings and bindings may be twisted upon tensioning. The total twist on each strap may equal three twists of 360°. The twist may also be located in those parts of the strap resting on the load, e.g. on the curve of a pile of logs, or over a dovetailed stack of tubing.

No twisting of the strap is permitted in edged areas, e.g. packages of sawn timber, girders, wagon sides, etc.

#### Examples of tensioning buckles

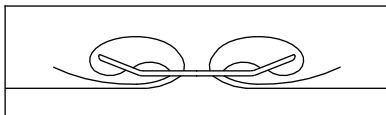

Figure 1 tensioning buckle

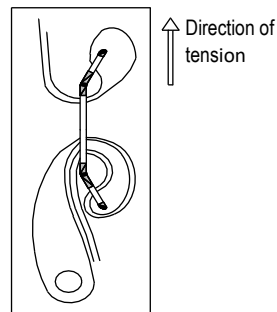
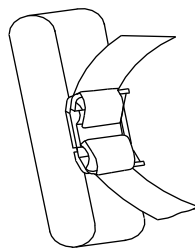

Figure 2 Creation of a slipknot

### For optimum use

The bindings should be protected against fraying on sharp edges by appropriate means.

<sup>1)</sup> Minimum breaking strength in tangent traction is equivalent to twice the permissible traction strength (LC) and only applies to synthetic straps, woven straps and load-securing straps, as well as lashing steel wire ropes and lashing chains.

## 0.6

### Lashing

1. Encircle the loaded goods.
2. Fit the tensioning buckle (figure 1).
3. Tighten with the removable tensioner.

### Direct fastening

1. Pass the strip through/around the securing points on the wagon and around the load.
2. Fit the tensioning buckle.
3. Tighten with the removable tensioner.

### Indirect fastening

1. Fit the slip knot with the tensioning loop through/around the wagon securing points (figure 2).
2. Pass the bindings over the loaded goods and through/around the wagon securing points.
3. Fit the tensioning buckle.
4. Pre-tension (300 daN minimum) using the removable tensioner.

### Quality control

By analogy with EN 12195-2:

Document result of check (straight pull), including the tensioning device.

#### Annealed steel wire

S 37 (new S 235 in EN 10027)

Steel wire Ø [mm]	Breaking strength of 1 wire R <sub>m</sub> [daN]	Breaking strength of 2 wires R <sub>m</sub> [daN]	Breaking strength of 4 wires R <sub>m</sub> [daN]	Cross-section of wire A [mm <sup>2</sup> ]
4	456.12	912.24	1824.49	12.57
5	712.69	1425.38	2850.76	19.63
6	1026.27	2052.55	4105.09	28.27
8	1824.49	3648.97	7297.94	50.27
10	2850.76	5701.52	11403.04	78.54

## 0.7 Indirect fastenings

### Purpose

With indirect fastenings, the load is “pressed” against the loading surface using bindings.

This

- improves the overall stability of the load unit and/or,
- ① - increases the contact pressure on the load and limits its potential for longitudinal movement.

### Goods

Individual items (like boxes), objects bound together to form load units (packages, bales, etc.) and stacked goods that can be pressed sufficiently securely against the loading surface with bindings.

### Wagons

Wagons with built-in indirect fastening systems or wagons with securing devices (e.g. rings, hooks, eyelets)

### Bindings

- ② - should be preferably woven or synthetic straps (see also information sheet 0.6),
- Metallic bindings have only limited suitability because of their low elasticity. Bindings made from steel strip may not be used,
- They must be equipped with a built-in tensioning system or separate tightening device,
- Straight pull breaking strength<sup>1)</sup> (including connecting parts) of between 1000 daN and 4000 daN, with a minimum pre-tension of 300 daN, according to the weight, length and surface of the goods and the lashing angle  $\alpha$ ,
- Straps should be protected from fraying on sharp edges by means of inserts, rubber hosing or corner protections.

The buckles and locking devices on the securing straps must be suited to the type of strap used in terms of its functional properties and strength.

The bindings must, as far as possible, be fixed using:

- hooks. Hooks must be equipped with a safety device against inconvenient unhooking, except in an enclosed cargo space.

The design of the lashing point and the triangle must be adapted to each other to prevent inconvenient unhooking.

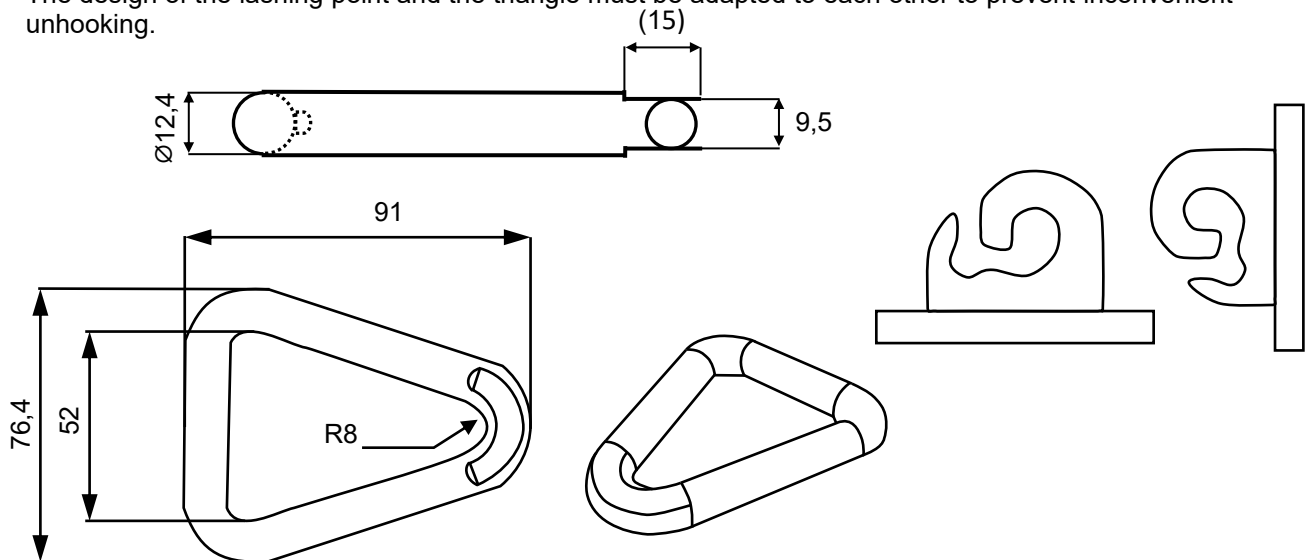

- or tensioned in loops (loops double the breaking strength). Use of knots reduces the breaking strength of the bindings by approx. 60%. If knots are used, the diminished breaking strength must be compensated for by means of suitably stronger bindings.

The following factors are crucial when pre-tensioning a binding:

- the pre-tensioning force,
- the lashing angle  $\alpha$  (measured between the loading surface and the binding). The smaller the lashing angle, the higher the pre-tensioning force in the binding must be to obtain the same contact force. The lashing angle  $\alpha$  must be at least 35°.

<sup>1)</sup> Minimum breaking strength in tangent traction is equivalent to twice the permissible traction strength (LC) and only applies to synthetic straps, woven straps and load-securing straps, as well as lashing steel wire ropes and lashing chains.

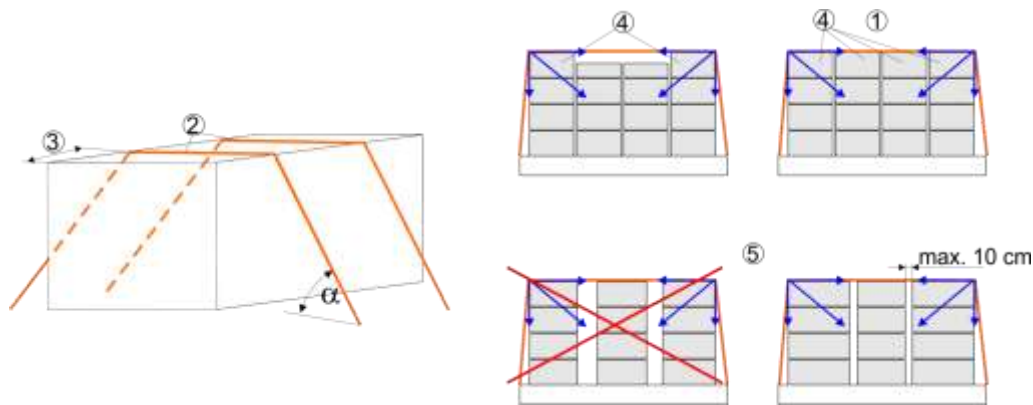

On sharp edges, the bindings must be protected by means of inserts, corner protection or rubber hosing. For goods with a smooth surface, indirect fastenings should be used in combination with friction-enhancing inserts made from a suitable material.

Indirect fastenings can only be used to secure those parts of the load that can be pressed sufficiently securely onto the loading surface. The load must not be damaged by the bindings.

### Attaching the bindings to the wagon

- Use the rings, hooks or eyelets made of steel rod (diameter at least 16 mm) fitted to the wagon.
- Eyelets and rings designed for fixing sheets on wagons may not be used for indirect fastening of goods with a unit mass of more than 4 t,
- Hooks and securing rings on stanchions may only be used if the stanchions are secured against uplifting.
- If there are no securing points in suitable positions, the goods may be fastened using appropriate parts of the wagon. However, bindings may not be attached to parts of the wagon running gear or suspension, nor to the bogies, signal brackets, door locking devices, handrails, steps, etc. Similarly, bindings must not be looped around draw gear, buffing gear or parts of the brake system, and must not pass beneath the underframe.

### Execution

If at all possible, bindings should be attached to the wagon using the securing devices provided (rings, eyelets, hooks). They should then be passed over the load (over tension) and tightened using the tensioning device (e.g. ratchet or lever).

The straps used for bindings may be twisted upon tensioning. The total twist on each strap may equal three twists of 360°.

The twist may also be located in those parts of the strap resting on the load, e.g. on the curve of a pile of logs, or over a dovetailed stack of tubing.

No twisting of the strap is permitted in edged areas, e.g. packages of sawn timber, girders, wagon sides, etc.

The free ends of the bindings must be secured and must not hang loose.

- ③ Each load unit requires at least two indirect fastenings, positioned approximately 50 cm from the ends of the load. Exceptions to these rules are explained in the loading guidelines and examples in volume 2.
- ④ Indirect fastenings can only protect those parts of the load that can be pressed sufficiently securely against the loading surface with bindings.
- ⑤ Empty space between load units lessens the effect of indirect fastenings as the bindings pull the individual units towards the middle of the wagon rather than pressing them against the loading surface.

For goods:

- with a smooth surface, indirect fastenings should be used in combination with friction-enhancing inserts made from a suitable material;
- with a fragile surface, indirect fastenings should be used in combination with inserts, rubber hosing or corner protection.

### Reference documents

EN 12 195-1: "Calculation of lashing forces",

EN 12 195-2: "Web lashing made from man-made fibres",

EN 12 195-3: "Lashing chains",

EN 12 195-4: "Lashing steel wire ropes".

The reference to the corresponding standard refers to the current version.

## 0.8 Friction and coefficients of friction

### Introduction

The friction forces between the loading surface and the load, between loads stacked on one another or when anti-skid materials are extremely important in securing loads as they have a direct influence on the design of additional devices used to secure the load. It is therefore highly important to determine the stable friction coefficients of the materials or characteristic friction pairs between loads and securing devices of goods transported on vehicles.

### Friction

Friction is the interaction between the surfaces of bodies in contact with one another (e.g. loading surface, loads, anti-skid inserts) preventing or impeding movement between these bodies.

Due to the effects of running dynamics, only sliding friction is taken into consideration when securing loads transported by railway.

### Sliding friction

Sliding friction  $F_{GL} = \mu_{GL} \cdot F_N$  is always lower than adhesion  $F_H$ .

In the UIC loading guidelines,

- the decisive parameter to evaluate the securing of the load is the friction coefficient  $\mu_{GL}$  only; it is calculated for the friction pairs formed by the load and the loading surface, or between the loads themselves,
- the sliding friction coefficient is named friction value or friction coefficient  $\mu$ .

Below a non-exhaustive enumeration of the sliding friction coefficients compared to the pairs of materials

Table of sliding friction coefficients “ $\mu$ ” (source: VDI 2700 directive)

Material	dry	wet	greasy
Wood / wood	0.20 – 0.50	0.20 – 0.25	0.05 – 0.15
Metal / wood	0.20 – 0.50	0.20 – 0.25	0.02 – 0.10
Metal / metal	0.10 – 0.25	0.10 – 0.20	0.01 – 0.10
Concrete / wood	0.30 – 0.60	0.30 – 0.50	0.10 – 0.20

Table of sliding friction coefficients “ $\mu$ ” (source: Fraunhofer Institute)

Material	dry	wet	greasy
Concrete products			
Prefabricated panel / used wood	0.50	0.50	
Prefabricated panel / new wood	0.40	0.40	
Prefabricated panel / prefabricated panel	0.55	0.55	
Steel frame / wooden loading surface	0.40	0.40	
Wooden beam / wooden loading surface	0.50	0.50	
Paper products			
Paper / paper	0.40		
Packed paper rolls / anti-skid floor	0.30		
Non-packed paper rolls / anti-skid floor	0.25		
Packed paper rolls / loading surface with planks	0.40		
Non-packed paper rolls / loading surface with planks	0.45		
Packed paper rolls / metallic floor	0.30		
Non-packed paper rolls / metallic floor	0.30		
Packed paper rolls / synthetic material	0.25		
Non-packed paper rolls / synthetic material	0.15		

## 0.8

Table of sliding friction coefficients “ $\mu$ ” (source: DEKRA)

Goods packed in sheeting	0.20 – 0.50
Cardboard packing	0.20 – 0.50
Wooden pallet / anti-skid floor	0.30 – 0.35
Pallet made of synthetic material / anti-skid floor	0.20 – 0.25
Rubber tyres / steel loading surface	
dry / clean surface	0.40 – 0.45
dirty / dry surface	0.30
dirty / wet surface	0.10 – 0.20

### Determining the friction coefficient

The standard EN 12195-1, edition 1.2011, includes a description in Annex B of a procedure to determine the friction coefficient in practice.

### Marking on packing increasing the friction coefficient

The marking consists of a pictograph representing an arrow, the tip of which points towards the contact surface with an increased friction coefficient.



### Measures geared towards increasing the friction coefficient

When using anti-skid materials, it is important to select the optimum technical solution in order to achieve the highest possible friction coefficient, ideally  $\mu > 0.7$ .

The friction coefficient that can effectively be achieved must then be considered on a case-by-case basis, as must the purpose of use (immobilising the load or limiting its movements).

The dimensions of the materials in use shall vary according to the weight of the load. The strength to be required of the friction-enhancing material must be suited to the masses to be secured.

Anti-skid materials	Behaviour with regard to deformation and concentrated loads	Pressure stress
Anti-skid matting (ASM) with hollow spaces	After applying a load as per DIN 15155 for 24 h, total weight of 1000 kg, no residual deformation affecting functioning may be apparent.	In case of high pressure, ASMs with a high proportion of hollow space tend to stiffen, in which case $\mu$ may decrease considerably. Comply with manufacturer's requirements.
Anti-skid matting with no hollow spaces		Comply with manufacturer's requirements (in case of PUR material, no higher than 80 N/mm <sup>2</sup> )
Fibrous material with anti-skid coating (felt)	If the load is localised and heavy, deformations or compression marks may occur, though they can have a positive effect, preventing the load from sliding further.	Comply with manufacturer's requirements
Solid cardboard with anti-skid coating	When using single-use products, it is unnecessary to check the effect of deformations or compression marks. If the load is localised and heavy, deformations or compression marks may occur, though they can have a positive effect, preventing the load from sliding further.	Comply with manufacturer's requirements
Solid cardboard or corrugated cardboard with anti-skid coating, with synthetic supporting material inside		Comply with manufacturer's requirements
Woven anti-skid material on both faces	Within the use and temperature ranges specified by the manufacturer, no significant residual deformation may be apparent.	In case of high pressure, ASMs with a high proportion of hollow space tend to stiffen, in which case $\mu$ may decrease considerably. Comply with manufacturer's requirements.
Woven anti-skid textile products on both faces	If the load is localised and heavy, deformation may occur. Under normal circumstances, practically no compression marks may be apparent, due to the thickness of the material and other properties.	In the absence of any general instructions, comply with manufacturer's requirements.

Source: VDI directives, VDI 2700 directive, sheet 15, securing loads on road vehicles, anti-skid material (May 2009)



## 0.9 Long load units on two carrier wagons with swivelling / sliding-swivelling bolsters

### Loading

Long self-supporting loads which have to be loaded on several wagons equipped with two swivelling / sliding-swivelling bolsters due to their length or weight.

Loads with a narrow profile which may bend crosswise due to stresses during carriage, must be strengthened using a suitable method, for example by assembling several beams into a single load unit or setting up ancillary structures along the sides of the load.

### Loading devices

- ① The swivelling bolster fixes the load on the carrier,
- ② The sliding-swivelling bolster enables longitudinal movement between the load and the wagon when negotiating curves and longitudinal movement of the buffing and draw gear.  
Swivelling / sliding-swivelling bolsters are generally equipped with lateral load-securing devices (stanchions, sides, end walls or fastening pads).  
Before loading it is necessary to check that the swivelling / sliding-swivelling bolster can pivot freely.

### Wagons

- two flat wagons of the same type
  - with in-built fixed swivelling bolsters **or**
  - with removable / transferable swivelling / sliding-swivelling bolsters
- ③ if necessary, using an intermediate wagon (flat wagon with collapsible boards and folded or removable stanchions), **or**
- ④ guard wagons (flat wagons with collapsible boards and foldable or removable stanchions);
  - articulated wagon with in-built fixed swivelling bolsters.

### Method of loading

- ⑤ Swivelling / sliding-swivelling bolsters should be placed above the longitudinal axis of the carrier wagons, as centred as possible within a range of  $\pm 1$  m; in case of an off-centre load, the permissible load capacity of the wagon must be observed.  
Removable / transferable swivelling / sliding-swivelling bolsters must be secured sufficiently to withstand potential stresses.

#### Loading:

- with the centre of gravity of the load above the longitudinal axis of the wagons and between the swivelling bolsters,
- ⑥ - the load must project above the swivelling bolsters by at least 1 m. For other load units (e.g. concrete sleepers), exemptions are granted when the contact points required by the design must be observed. In this case, the necessary measures must be taken to ensure the load unit cannot slide beyond the swivelling bolsters.
  - concerning vibrations, observing the ratio:  $n_i : n_a = 2.67:1$  provides the optimum conditions,
  - in case of coupled wagons with two in-built swivelling bolsters and without sliding-swivelling bolsters, the load is secured on one swivelling bolster with longitudinal movement possible on the second bolster.

#### Loading with guard wagons ④

- If the load units project above the bolsters at the front of the carrier wagons and the measures as per point 4.2 of volume 1 are not observed, guard wagons are required. Guard wagons may be loaded with other goods in accordance with the UIC Loading Guidelines.

In this case the consignor RU determines the minimum distances:

- ⑦ - horizontally between the loads,
- ⑧ - vertically between the load and the intermediate wagon ③ / buffer wagon ④.
- ⑨ It must be checked that the loading gauge and width limits for the load units as per tables 1 and 2 of volume 1 of the UIC Loading Guidelines are being observed.

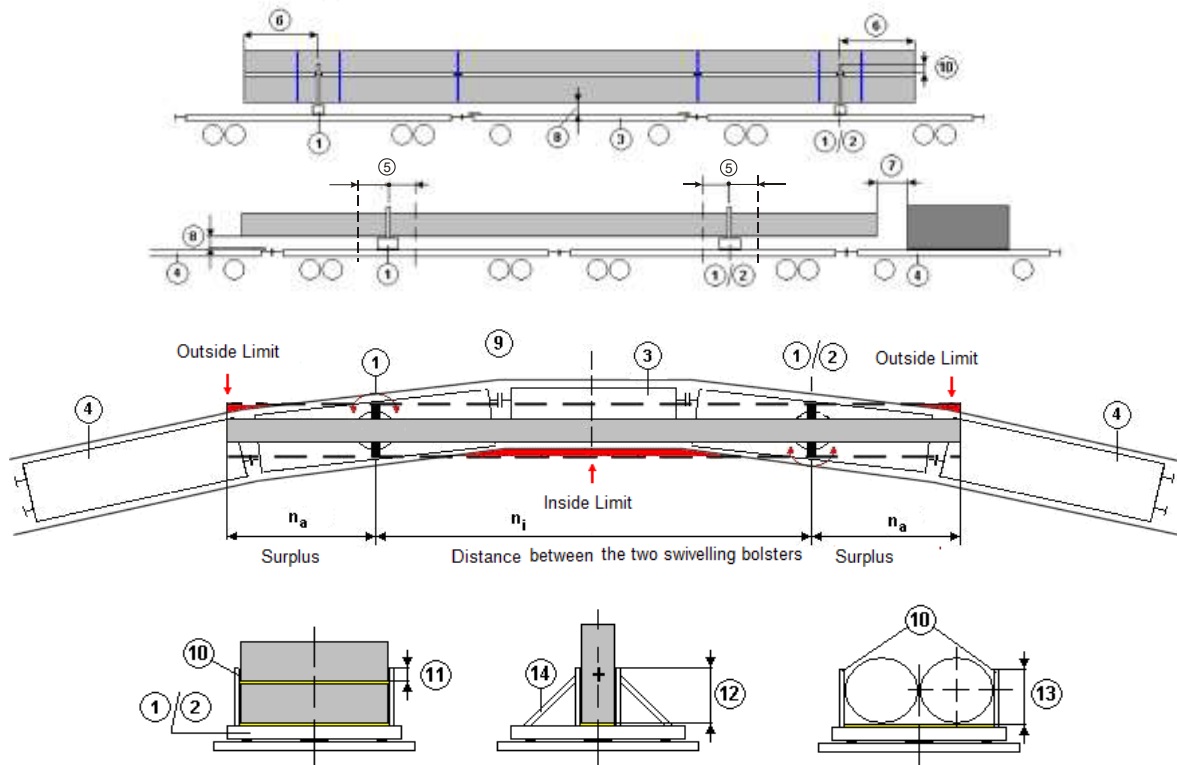

## Securing

In principle, the load is secured only on the two swivelling bolsters.

- along the length of the wagon
    - in case of two in-built swivelling bolsters:
      - secured on one swivelling bolster with longitudinal movement possible on the other swivelling bolster.
      - secured on the two bolsters in case of swivelling / sliding-swivelling bolsters.
  - across the wagon
- ⑩ secured from moving and being overturned transversally by stanchions or the sides of the swivelling / sliding-swivelling bolsters if:
- the load is in direct contact with the stanchions or sides,
  - the effective height of the stanchions or sides is
    - ⑪ at least 10 cm,
    - ⑫ in case of load units likely to tip, at least as high as their centre of gravity,
    - ⑬ in case of load units likely to roll, at least as high as half their diameter.
- ⑭ If this is not possible the load must be secured crosswise by suitable devices such as ancillary structures, materials increasing the coefficient of friction, indirect fastenings, etc.

## Operating conditions

These consignments may not be subject to hump or fly shunting, nor may they collide with other vehicles that have been fly or hump shunted.

The transport units must be coupled in such a way that the buffers are in slight contact.

Trains including these transport units may not be pushed.

If the brake of a wagon forming part of a transport unit has to be isolated, the brakes on other wagons (carrier wagons, intermediate wagons and guard wagons) also have to be isolated.

## Additional indications

The consignments are exceptional consignments.

For load of wagons, maximum dimensions of loads and indirect fastenings, see information sheets 0.1, 0.2 and 0.7.

## 0.10 Wooden load carriers/pallet

### Purpose

Wooden pallets are used to carry goods - they are a part of packaging and aid efficient handling during loading and unloading, storage and carriage of goods by all means of transport, particular the railways.

Use of pallets for loading facilitates optimal distribution of the full mass of the goods on the wagon's payload area, protects the freight wagon's payload area from damage and enables safe loading with conveyor systems, e.g. pallet jacks or forklifts.

During packaging, the goods must be fastened to the pallet so that the two components together form a load unit. Binding materials (straps, stretch film, etc.) are used for fastening and must be designed for the mass loaded on the pallet. The load must be fastened to the pallet by binding materials so as to prevent displacement of the load on the pallet.

### Type of goods loaded

Stacked goods or individual heavy goods with the maximum permitted total weight, which can be bound with sufficient strength to the pallet by means of binding materials.

### Wagons

All types of wagons with which floor conveyor systems can be used.

### Wooden transport pallets

As a load carrier, a pallet must bear load weight statically and must dynamically resist the acceleration forces which may occur during rail transport. One-way pallets or reusable pallets may be used.

**One-way pallets** are intended for single shipment from the manufacturer to the consumer and are often used for export. Because they are single-use pallets, they are generally disposed of by the recipient. Their technical parameters, particularly load capacity, are not guaranteed.

**Reusable pallets** are more stable, have a longer life than one-way pallets and are designed to be used numerous times. They are always manufactured in accordance with a strictly defined standard. These pallets are exchangeable and repairable. They can always be accessed on all four sides with a forklift. Reusable pallets can be exchanged as part of a shared pallet pool and bear the recognised identifier for this pool. There are numerous pallet pools. The standards according to which the various types of pallets are produced should/must be accessible to the user.

Required technical parameters for a reusable pallet:

- Dimensions of 800 mm x 1200 mm,
- Loading capacity – the following maximum loads are permitted:
  - 1,500 kg if the load is distributed equally over the surface of the pallet;
  - 4,000 kg if on an even, horizontal and rigid surface and the load is horizontal and distributed across the entire surface.

The technical parameters of a reusable pallet, particularly load capacity, must be guaranteed and their quality must be verified by a test organisation recognised by the licensor. The quality assurance measures that have been taken are evident from a control clamp on the centre block lengthways on the pallet.

## Requirements for a reusable pallet approved by UIC (source: UIC Leaflet 435-2/IRS 40435-2)

EUR load carrier made from wood, 1200 x 800 mm - parts list with tolerances

Part no.	Number of units	Description of parts	Nominal dimensions (mm) L x W x H	Tolerances (mm)		
				L	W	H
1	2	Board forming bottom edge	1200 x 100 x 22	+3/-0	+3/-3	+2/-0
2	2	Top edge board	1200 x 145 x 22	+3/-0	+5/-3	+2/-0
3	1	Bottom centre board	1200 x 145 x 22	+3/-0	+5/-3	+2/-0
4	3	Cross piece	800 x 145 x 22	+3/-0	+5/-3	+3/-0
5	1	Top centre board	1200 x 145 x 22	+3/-0	+5/-3	+2/-0
6	2	Top intermediate board	1200 x 100 x 22	+3/-0	+3/-3	+2/-0
7	6	Block	145 x 100 x 78	+5/-3	+3/-3	+2/-0
8	3	Block	145 x 145 x 78	+5/-3	+5/-3	+1/-1
9	27	Convex ring nails	4.2 x 70	*	*	*
10	27	Anti-split screws	5.2 x 70	*	*	*
11	24	Convex ring nails	4.2 x 38	*	*	*
12	24	Anchoring nails	2.8 x 56	*	*	*
13	24	Machine nails	2.5 x 60	*	*	*
14	24	Clamp	2.2 x 14 x 53	*	*	*
15	27	Convex ring nails	4.2 x 90	*	*	*
16	27	Anti-split screws	5.2 x 90	*	*	*

: \* see UIC Leaflet 435-2 (IRS 40435-2)

### Approved reusable pallets:

#### A) UIC pallets

UIC defines the characteristics of UIC/EUR pallets in UIC Leaflet 435-2 (IRS 40435-2). UIC and its member RUs accept the UIC/EUR pallets defined in UIC Leaflet 435-2 (IRS 40435-2)

Their identifying features are as follows:

- UIC trademark on the left corner block,
- Due to obligatory phytosanitary measures, the label for phytosanitary heat treatment prescribed by the authorities must be affixed to both centre blocks (ISPM 15) on the 1,200 mm side.

A readable line containing the manufacturing code, with the year and month of manufacture as well as the label of the licensing RU must be added underneath.

- EUR trademark in an oval on the right corner block.

Reusable pallets of this type are produced by approved manufacturers or repaired by approved repairers only. Their basic technical parameters have been checked by manufacturers and repairers from independent testing organisations.

#### B) Other reusable pallets:

Pallets other than UIC pallets may also be used, provided that they are equivalent in structure to UIC pallets. They are accepted by UIC and its member RUs.

Such other reusable pallets accepted by UIC member railways on the basis of structural equivalence are defined in the current version of EN 13698-1.

The associated conditions for manufacturing and approval of reusable pallets other than UIC pallets are to be clarified directly with the relevant licensor.

### Reference documents

UIC Leaflet 435-2 (IRS 40435-2): Standard of quality for a European flat pallet made of wood (EUR-1)

EN 13698-1 Pallet product specification

All references to standards refer to the current version.

# Chapter 1: Metal



## 1.2.2 Steel sheet in packages on bound-in timbers placed crossways, able to slide

Single wagons and groups of wagons

Wagons in block trains or combined transport  
Wagons with long-stroke shock absorbers

### Type of goods

- ① Packages of steel sheet on grooved timbers, bound-in crossways.
- ② Height of packages
  - max. 75 cm with U-shaped edge protection or closed steel sheet packing,
  - max. 50 cm without edge protection or packing.
- ③ Packages should be bound crossways with steel strip (breaking strength<sup>1)</sup> at least 1400 daN) at intervals of approx. 1 meter and at least three bindings for packages  $\leq 3$  m. Synthetic straps should only be used with edge protection.  
If the 1 m spacing cannot be observed when binding the packages together, the missing bindings should be compensated for by additional fastenings on the stacks ⑧

### Wagons

Wagons with wooden floor

### Method of loading

- ④ Packages of the same length and width in up to 6 tiers and a stacked height of 1.25 m, though no higher than the width of the packages. Goods spread evenly over the wagon floor insofar as possible (in compliance with ⑦). The difference in height between two adjacent stacks must be less than the height of one package. Between the individual packages, use friction inserts or non-slip packaging.
- ⑤ Smaller individual packages on the top of the stack.
- ⑥ Stacks loaded lengthways in the wagon on skids made from hard fiber panel (rough side facing down) or from other suitable material. The number, width and thickness of the skids must be such that the bound-in wooden timbers do not touch the wagon floor (at least three, spread regularly beneath the stack, min. width 15 cm).
- ⑦ Minimum clearances to be left at the wagon ends:

50 cm

0 cm

- ⑧ Stacks bound together crossways  
with **woven straps** with edge protection, min. breaking strength<sup>1)</sup> 2500 daN (straight pull):
  - at least 3 bindings for stacks of length  $\leq 3$  m,
  - at least 4 bindings for stacks of length  $> 3$  m.

or

with **steel strips**, min. breaking strength 2000 daN

- at least 3 bindings for stacks of length  $\leq 3$  m,
- at least 3 bindings for stacks of length  $> 3$  m + 1 binding every additional 2 m.

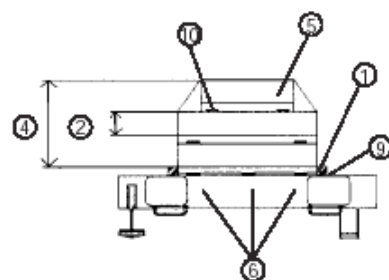
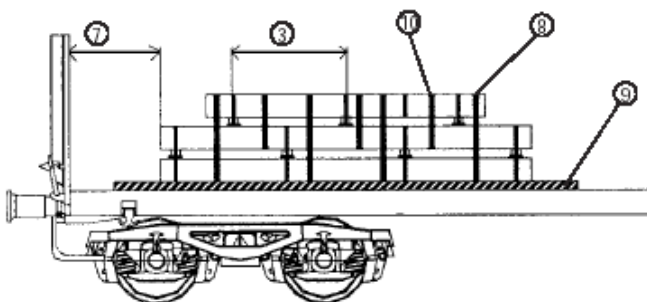

<sup>1)</sup> Minimum breaking strength in tangent traction is equivalent to twice the permissible traction strength (LC) and only applies to synthetic straps, woven straps and load-securing straps, as well as lashing steel wire ropes and lashing chains.

## 1.2.2

### Securing

- Lengthways in the wagon: Stacks loaded with possibility of sliding
- ⑨ Across the wagon: secured with guide-pieces, min. height 5 cm, min. effective height 3 cm. Fixed to the wagon floor with one nail per 1500 kg of load and at least two nails per guide-piece. Nails should have a min. diameter of 5 mm and penetrate at least 40 mm into the wagon floor.
- ⑩ Smaller packages on the top of the stack secured with
  - friction inserts and
  - fastenings to join them to the package below (for number of bindings and their arrangement see ⑧).

### Additional indications

Load of wagons: see information sheet 0.1,  
Single-use bindings: see information sheet 0.6,  
Friction and coefficients of friction: see information sheet 0.8.

## 1.2.3 Steel sheet in packages on timbers placed lengthways, able to slide

Single wagons and groups of wagons

Wagons in block trains or combined transport  
Wagons with long-stroke shock absorbers

### Type of goods

- ① Packages of steel sheet with or without timbers bound in.
- ② Height of packages
  - max. 75 cm with U-shaped edge protection or closed steel sheet packing,
  - max. 50 cm without edge protection or packing.
- ③ Packages should be bound lengthways and crossways with steel strip (breaking strength<sup>1)</sup> 1400 daN) at intervals of approx. 1 meter. At least two bindings per package side. Synthetic straps should only be used with edge protection.

### Wagons

Wagons with wooden floor

### Method of loading

- ④ Packages of the same length and width, in one or more tiers up to a height of 1.25 m, though no higher than the width of the packages. Goods spread evenly over the wagon floor insofar as possible (in compliance with ⑦). The difference in height between two adjacent stacks must be less than the height of one package. Stacks placed on timbers arranged lengthways in the wagon, with or without space between the stacks. Use the full length of the wagon if possible.
- ⑤ With bound-in and bevelled timbers  
or
- ⑥ on loose timbers.
- ⑦ Minimum clearances to be left at the walls or collapsible end boards:

50 cm

0 cm

- ⑧ Stacks should be bound lengthways and crossways with steel strip (breaking strength<sup>1)</sup> at least 2000 daN) at intervals of approx. 1 meter. The number of bindings should be doubled in the lengthways direction if the stack exceeds 35 cm. At least two bindings on each side of the stack. Synthetic straps should only be used with edge protection.

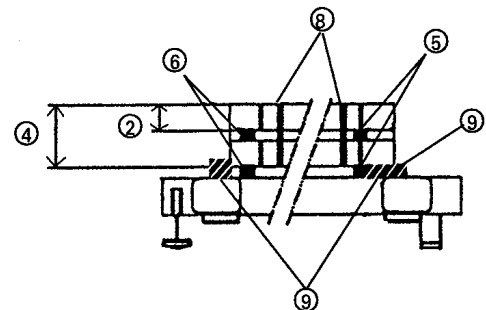
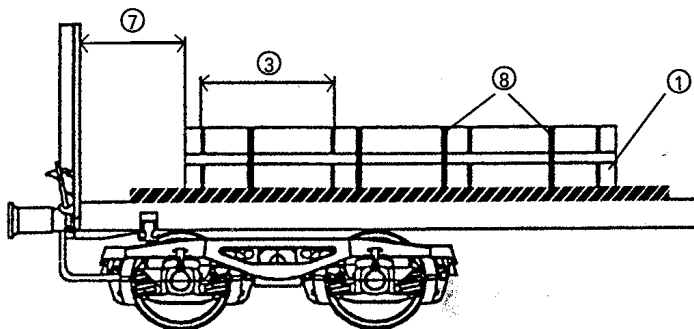

### Securing

- Lengthways in the wagon: loaded with possibility of sliding.
- ⑨ Across the wagon: secured with guide-pieces, min. height 5 cm, min. effective height 3 cm. Fixed to the wagon floor with one nail per 1500 kg of load and at least two nails per guide-piece. Nails should have a min. diameter of 5 mm and penetrate at least 40 mm into the wagon floor.

### Additional indications

Load of wagons: see information sheet 0.1,  
Single-use bindings: see information sheet 0.6

<sup>1)</sup> Minimum breaking strength in tangent traction is equivalent to twice the permissible traction strength (LC) and only applies to synthetic straps, woven straps and load-securing straps, as well as lashing steel wire ropes and lashing chains.



## 1.2.4 Heavy plates without timbers (ungreased)

Single wagons and groups of wagons

Wagons in block trains or combined transport  
Wagons with long-stroke shock absorbers

### Type of goods

- ① Plates without timbers (min. thickness: 3 mm), stacked to a height of roughly 80 cm.
- ② Individual stacks bound at least twice.
- ③ Dovetailed sheets, bound across the load at least three times, including once on the dovetailed sections.  
Type of binding: steel strip (breaking strength min. 1400 daN) with edge protection or steel wire (diameter 5 mm min. at least double-bound).

### Wagons

Wagons with side-doors/-walls or stanchions and wooden floor. For extra wide plates, side-walls and -stanchions folded down.

### Method of loading

- ④ Stack loaded directly onto the wagon floor, on bolsters or on softwood timbers with rectangular cross-section resting on the broader face. Plates should extend at least 50 cm beyond the timbers.
- ⑤ For loading on timbers, overhanging load ends shall be maintained at the same height by timbers sufficiently secured to wagon floor by nails.
- ⑥ Minimum clearance when the load projects beyond the end-doors/-walls:

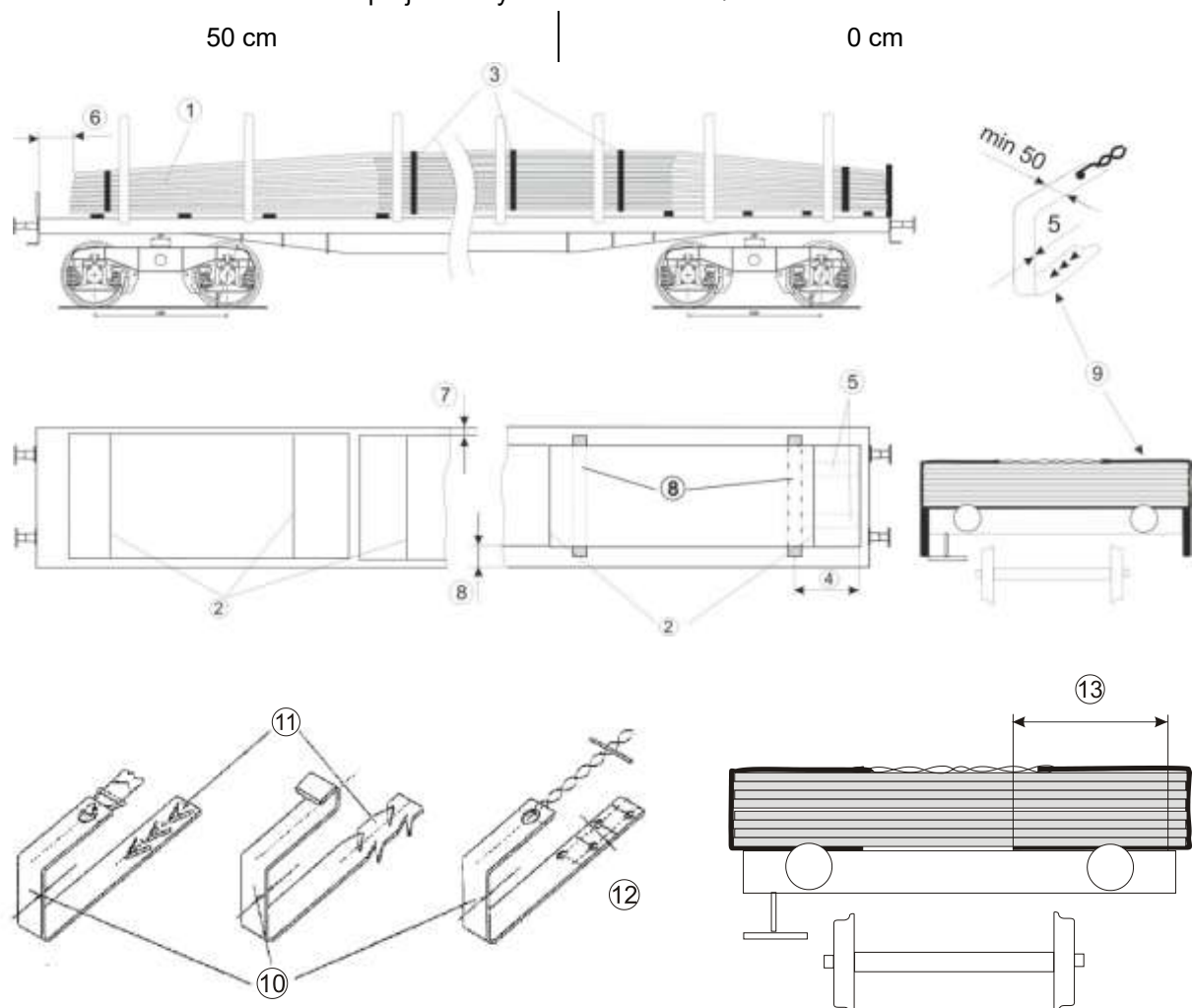

## 1.2.4

### Securing

- lengthways in the wagon:
  - by the end-walls or -stanchions,
- crossways in the wagon:
  - ⑦ • by side-walls or -stanchions when the distance from the side is no greater than approx. 10 cm. When secured by only two stanchions, plates must extend beyond the centre of stanchions by at least:
    - 50 cm
    - 0 cm
  - ⑧ • by nailed scotches, at least two per stack on each side when the distance from the walls or -stanchions is greater than approx. 10 cm; such scotches should be at least 5 cm thick and have an effective height of at least 3 cm;  
Number of nails on scotches on each side: one nail per 1500 kg **and/or**
    - Securing according to ⑨ or ⑩ and, if necessary, ⑭

For extra wide plates:

- ⑨ • by bands of fastened flat steels (breaking strength<sup>1)</sup> min. 2000 daN). The flat steels should stick into the floor with spikes or be nailed. Number of bands: at least three, for lengths up to 6 m and at least four, for lengths over 6 m, **or**
- ⑩ • by steel corner pieces (min. width: 50 mm, min. thickness: 5 mm).

Each corner piece is secured by:

- ⑪ • at least three blank spikes (h=30 mm) or at least four notched spikes (h=40mm); minimum; distance 40 mm min. **or**
- ⑫ • four nails (∅ 5 mm) or four threaded nails (∅ 4.2 mm) secured to the wagon floor or cross-piece. Penetration depth of nails: min. 40 mm, penetration depth of spikes: min. 30 mm (blank spikes) and min. 40 mm (notched spikes).
- ⑬ • Length of corner piece contact surface with wagon floor: 60 cm min.  
Timbers placed lengthways on the corner pieces at the level of the spikes/nails.  
The two corner pieces positioned opposite each other shall be bound together above the load (breaking strength<sup>1)</sup> of the binding: min. 2000 daN)

Number of corner pieces per wagon side:

- at least four, for lengths up to 6 m,
- at least five, for lengths over 6 m,
- in case of dovetailed sheets: one corner piece shall also be positioned on each side in the dovetailed sections,
- ⑭ - If the plates are different widths or if the lashing angle  $\alpha < 90^\circ$ , the plates which are not in contact with the bands/corner pieces must additionally be secured with friction-enhancing strips.

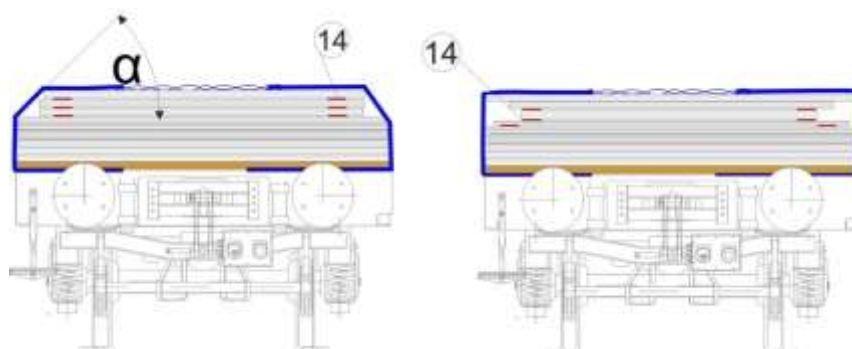

### Additional indications

Load of wagons: see information sheet 0.1

Maximum dimensions of loads: see information sheet 0.2

Friction, coefficients of friction, see information sheet 0.8

<sup>1)</sup> The minimum breaking strength (straight pull) corresponds to double the permitted tensile force (LC); this concerns only synthetic straps, woven-fabric straps and load securing straps, as well as lashing steel wire ropes and lashing chains.

## 1.2.5 Heavy plates (ungreased und particularly wide)

Single wagons and groups of wagons

Wagons in block trains or combined transport  
Wagons with long-stroke shock absorbers

### Type of goods

- ① Heavy ungreased plates (3 mm thick or more) wider than the effective width of the wagon.

### Wagons

Flat wagons with wooden floor

### Method of loading

- ② Plates stacked one on top of one another or individual interleaved plates **or**

Plates bound together in packages, stacked directly on the wagon floor, bolsters, or wooden timbers or intermediate timbers. Height of the packages: 10 cm max., breaking strength of the package bindings: 1400 daN min., with a binding every 3 m and at least two bindings per package.

- ③ Timbers and wooden intermediate timbers should be

- of rectangular cross-section resting on the broader face; intermediate timbers within a layer must all have the same height,
- vertically aligned one above the other
- positioned directly under the bindings and
- roughly as long as the load is wide, but no longer than the width of the load.

The thickest plates should be arranged in the lower part of the load and the load should be spread as far as possible over the full length of the wagon.

- ④ The height of the load should be 70 cm at most.

A free space of at least

50 cm

0 cm

is only necessary:

- if parts of the load protrude from the end walls,
- if the wagons are not equipped with end walls/stanchions
- on La... wagons in the direction of the short securings.

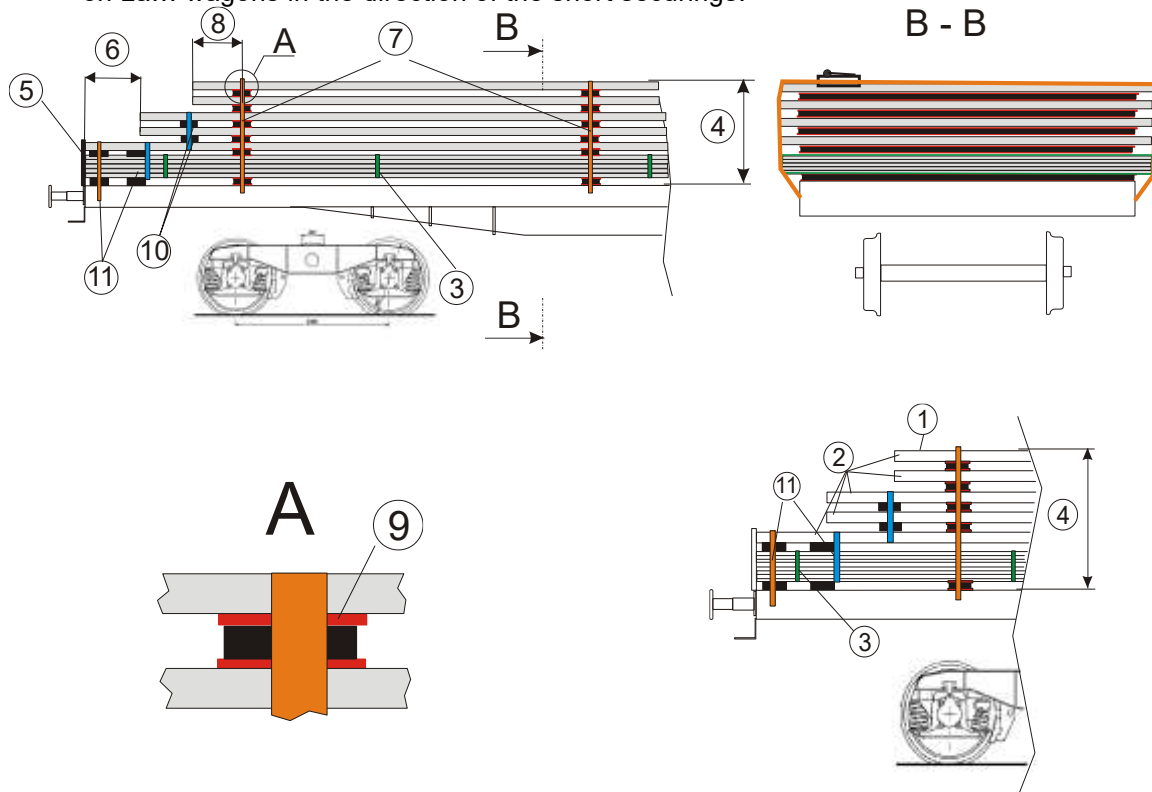

## 1.2.5

### Securing

Lengthways in the wagon by

- ⑤ • the end walls or
- ⑥ • free space at the ends of the load.

Crossways in the wagon:

- ⑦ • by indirect fastenings consisting of:
  - four annealed steel wires ( $\varnothing$  5 mm) **or**
  - tensioning straps combined with edge protection (breaking strength<sup>1)</sup> in tangent traction 5000 daN min.)

in direct contact with the timbers or intermediate timbers.

Bindings consisting of annealed steel wires should pass over the load and, on each side, through rings or other fastening devices on the wagon underframe, then back over the load before being twisted on either side. The lateral part of the load is thus secured by eight twisted wires.

- ⑧ • Each plate should be secured by at least two indirect fastenings; the plates should protrude from the bindings by at least 50 cm.
- ⑨ • An indirect fastening should be placed every 3 metres approx. Material increasing the coefficient of friction should be placed on and under the timbers/intermediate timbers.
  - The ends of the load sloping downwards must be supported by means of extra intermediate timbers.
- ⑩ If the plate thickness is sufficient, the timbers between the overhanging plates may rest on the plates underneath and must be bound with them to form a unit.  
Conversely, the entire stack must be supported by timbers or intermediate timbers bound to the stack plates to form a unit or secured by means of indirect fastenings as per ⑪.
- ⑪ The load is secured by means of bindings or woven straps (breaking strength of the bindings in tangent traction: 1400 daN min.) with edge protection; the timber under the load must be fixed to the wagon floor.  
Indirect fastenings: see no. ⑦

### Additional indications

Load of wagons: see information sheet 0.1

Maximum dimensions of loads: see information sheet 0.2

Single-use bindings: see information sheet 0.6,

Indirect fastenings: see information sheet 0.7,

Friction and coefficients of friction: see information sheet 0.8.

The strength of the inserts depends on the loading mass. Stress strength of the material increasing the coefficient of friction must suit the masses to be secured.

---

<sup>1)</sup> Minimum breaking strength in tangent traction is equivalent to twice the permissible traction strength (LC) and only applies to synthetic straps, woven straps and load-securing straps, as well as lashing steel wire ropes and lashing chains.

## 1.2.6 Heavy plates (ungreased)

Single wagons and groups of wagons

Wagons in block trains or combined transport  
Wagons with long-stroke shock absorbers

### Type of goods

- ① Stacked sheet metal separated by softwood timbers when required. Height of load: approx. 80 cm.  
In some instances, the stacking of sheet metal in such a way that the shortest and/or narrowest sheets are placed below or inside the stack is permissible. The difference in the size of the plates on each side must not exceed the following measurements:
  - a. 1 m lengthways (except for sheets at the top of the stack)
  - b. 0.5 m crossways (to take into consideration securing against tipping and vibration behaviour)
- ② Individual stacks up to 6m in length with at least two bindings and an additional binding every additional 6m or part thereof.
- ③ Dovetailed stacks bound once for every 6 metres with at least three bindings, of which at least one should be in the overlapping area.

Binding type: strip steel (breaking strength: 1400 daN) with edge protection.

### Wagons

Wagons with stanchions or flaps and a wooden floor. For the wide plates, fold down the flaps and the side stanchions.

### Method of loading

- ④ Stacks, with the plates being separated by softwood timbers when required, loaded directly onto the wagon floor, on bolsters or softwood supporting scotches with a square cross-section of at least 5 x 5 cm or a rectangular cross-section. When resting on their widest face, the plates should protrude beyond the lower intermediate timbers by at least 50 cm.
- ⑤ In the unlikely event that the lower timbers are positioned edgewise, they must be firmly secured against tipping.

If the goods are loaded onto supporting scotches, two, four or more supporting scotches should be evenly spread. The supporting scotches should cover at least  $\frac{3}{4}$  of the width of the sheet that they are supporting. Each supporting scotch must be secured against transverse movement, by a minimum of two nails, for example.

The supporting scotches/timbers may consist of several superimposed components, as long as these are adequately bound together.

Timbers

- Number dependent on the nature of the plates (the timbers do not necessarily have to be placed on the same vertical plane);
- ⑥ - Minimum length of the timbers approximately  $\frac{3}{4}$  of the width of the sheet they are supporting;
- With a square or rectangular cross-section, resting on the widest face, consisting of one piece or
- Of maximum of two components, overlapping laterally by at least  $\frac{1}{3}$  of the total length of the timber and adequately bound;
- Of the same thickness within layers;
- Must not destabilise the stack;
- Maximum permitted height for the stack must not be exceeded.

The timbers must be secured against crossways movement by means of, for example, the following:

- ⑦ - a friction-increasing fabric fixed on top of or below the timber.
- ⑧ - laterally positioned abutments.

If the length of the timber stacks in tiers is approximately  $\frac{3}{4}$  of the width of the plate which it is supporting, and if the timbers and supporting scotches are vertically aligned, it is not necessary to provide additional securing against crossways movement. If the timbers and supporting scotches are not vertically aligned, additional securing against crossways movement in accordance with ⑦ is required., it is not necessary to provide additional anchoring against crossways movement.

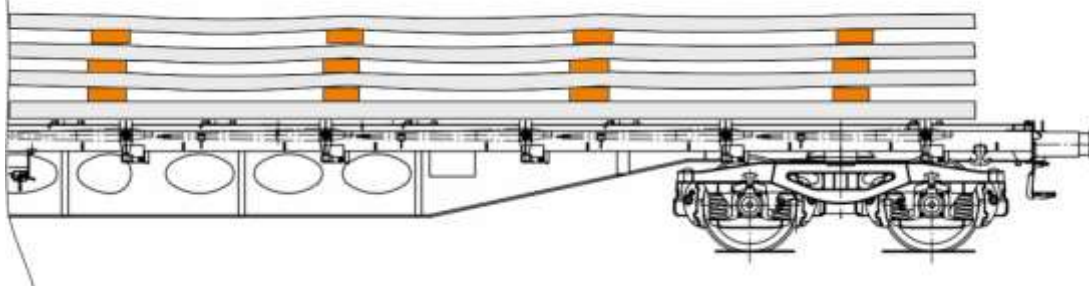

### 1.2.6

- ⑨ If the goods are loaded onto supporting scotches, the protruding extremities of the load are to be supported by wooden blocks of approximately the same height and which are adequately fixed to the floor of the wagon.
- ⑩ The directly stacked plates are in contact with one another over their entire surface. If contact is not assured over the entirety of the surface, a sufficient number of anti-skid strips should be inserted. The minimum width of the strips is 15 cm, and their minimum length is  $\frac{3}{4}$  of the plate's width.
- ⑪ If the goods exceed the height of the panels or end flaps, the minimum clearance is as follows:

50 cm

0 cm

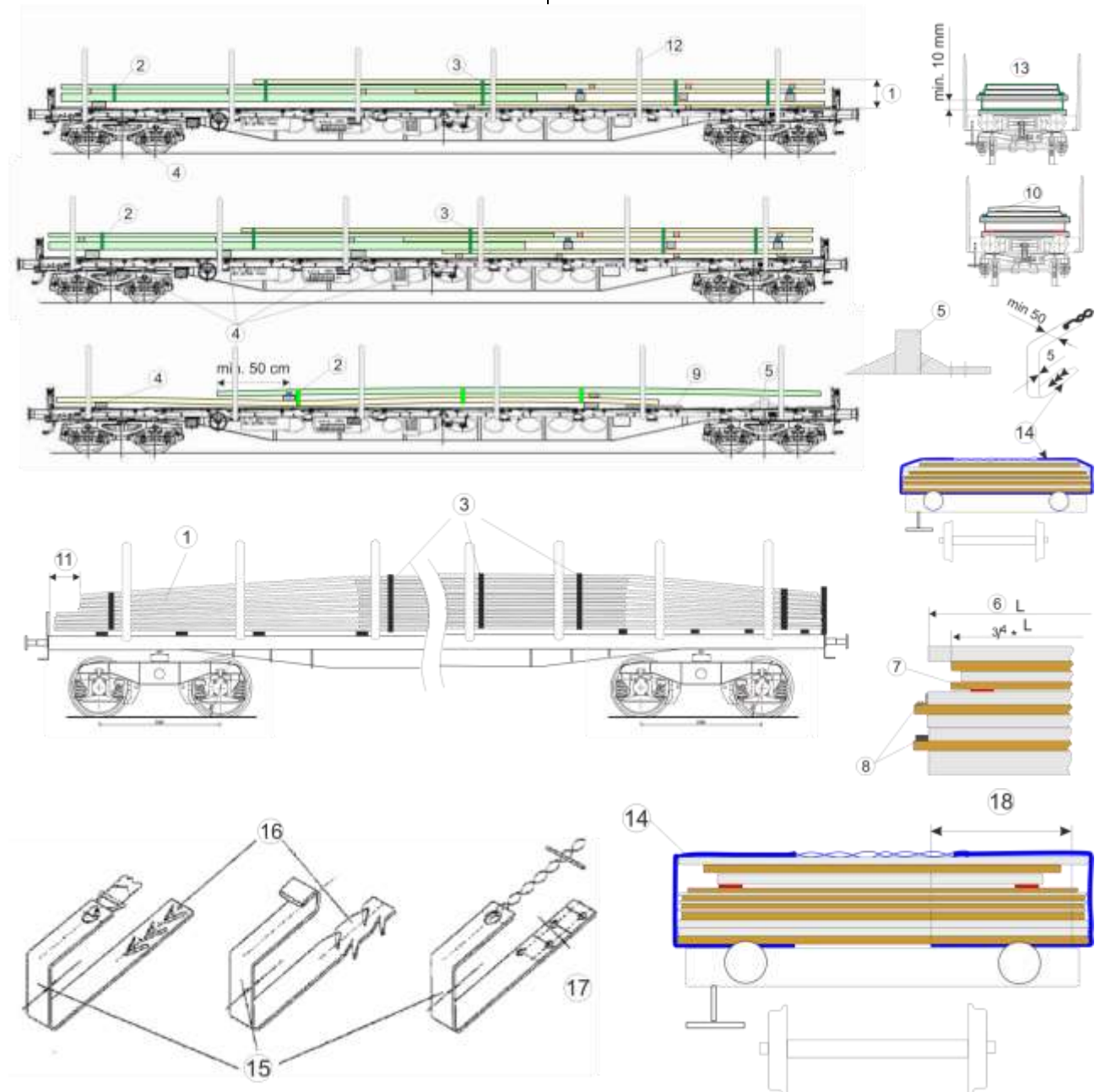

## Securing

- Lengthways on the wagon:
    - by the flaps or end stanchions.
  - Transversally on the wagon:
    - ⑫ • by the lateral flaps or the stanchions  
when the lateral deviation in relation to the edges or stanchions is greater than approximately 10 cm:
      - Loading onto
    - ⑬
      - softwood scotches exceeding both sides of the load in width. There should be a minimum thickness of 10 mm for a sheet resting on a softwood scotch **or**
      - Material increasing the friction coefficient
- or else**
- By blocks of nailed down wood with a minimum thickness of 5 cm and a minimum effective height of at least 3 cm, at least two per stack on each side. Number of nails in the wooden blocks – one for every 1500 kg of cargo, spread evenly across all the blocks.
  - In the event of securing by two stanchions, the plates must exceed the centre of the stanchions by a minimum of

50 cm

0 cm

For particularly wide plates

- ⑭ • by straps composed of bound steel plates (breaking strength min. 2000 daN). The steel plates are secured to the flooring by spikes or are nailed down; number of straps – at least three for lengths of up to 6 meters and at least four for lengths of greater than 6 m **or**
  - ⑮ • by steel fastening brackets (minimum width 50 mm, minimum thickness 5 mm),  
secured by
  - ⑯ • at least three indented spikes (length = 30 mm) or at least four notched spikes (length = 40 mm); minimum spacing 40 mm **or alternatively**
  - ⑰ • four nails each ( $\varnothing$  5 mm) or four screw nails ( $\varnothing$  4.2 mm) nailed into the flooring or bolsters. Minimum penetration depth of nails – 40 mm and 30 mm or 40 mm for spikes.
  - ⑱ • Minimum bearing length of fastening brackets – 60 cm.
- The supporting scotches are placed lengthways on the fixing brackets on the spikes/nails. The two fixing brackets are positioned opposite each other and are bound together above the load (minimum breaking strength: 2000 daN)

Number of fixing brackets for each side of the wagon:

- A minimum of four for up to 6 m
- A minimum of five for lengths of greater than 6 m
- One fixing bracket also in the overlapping zone for dovetailed stacks.

## Additional indications

Load of wagons: see information sheet 0.1

Maximum dimensions of loads: see information sheet 0.2

Single-use bindings<sup>1)</sup>: see information sheet 0.6,

The actual number of bindings depends on the mass, length, nature and vibration behaviour of the load and the binding angle ( $\alpha$ ).

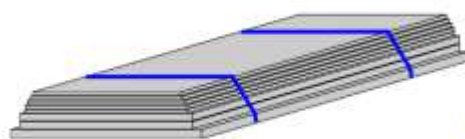

Binding/lashing angle  $\alpha$



Friction and coefficients of friction: see information sheet 0.8.

<sup>1)</sup> Minimum breaking strength in tangent traction is equivalent to twice the permissible tensile strength (LC) and only applies to synthetic straps, woven straps and load-securing straps, as well as lashing steel wire ropes and lashing chains.



### 1.3.1 Coiled sheet (greased or ungreased)

Single wagons and groups of wagons

Wagons in block trains or combined transport  
Wagons with long-stroke shock absorbers

#### Type of goods

Coiled sheet, loaded on the roll, with a maximum weight (individually or per group) of 7 t.

- ① each coil bound twice around the circumference
- ② greased metal sheets should also be bound three times through the mandrel hole,
- ③ several coils bound together four times through the mandrel hole.

Type of binding: steel strip with a breaking strength of at least 1400 daN for binding individual rolls and at least 2000 daN for binding together several coils.

#### Wagons

Wagons with walls or sides and wooden floor.

#### Method of loading

Coiled sheet

- ④ - loaded directly onto the wagon floor or on softwood timbers laid lengthways in the wagon (cross-section of approx. 5 x 12 cm) resting on the broader face
- ⑤ - individually, when the width is at least  $\frac{5}{10}$  of the diameter,
- ⑥ - side by side and bound into one unit when the width of each individual coil is at least  $\frac{1}{3}$  of the diameter and the total width of each unit is at least  $\frac{7}{10}$  of the diameter,
- ⑦ - in groups, one behind the other (touching); for loads in excess of 7 t, separate groups should be formed
- ⑧ Clearance: at least 50 cm.

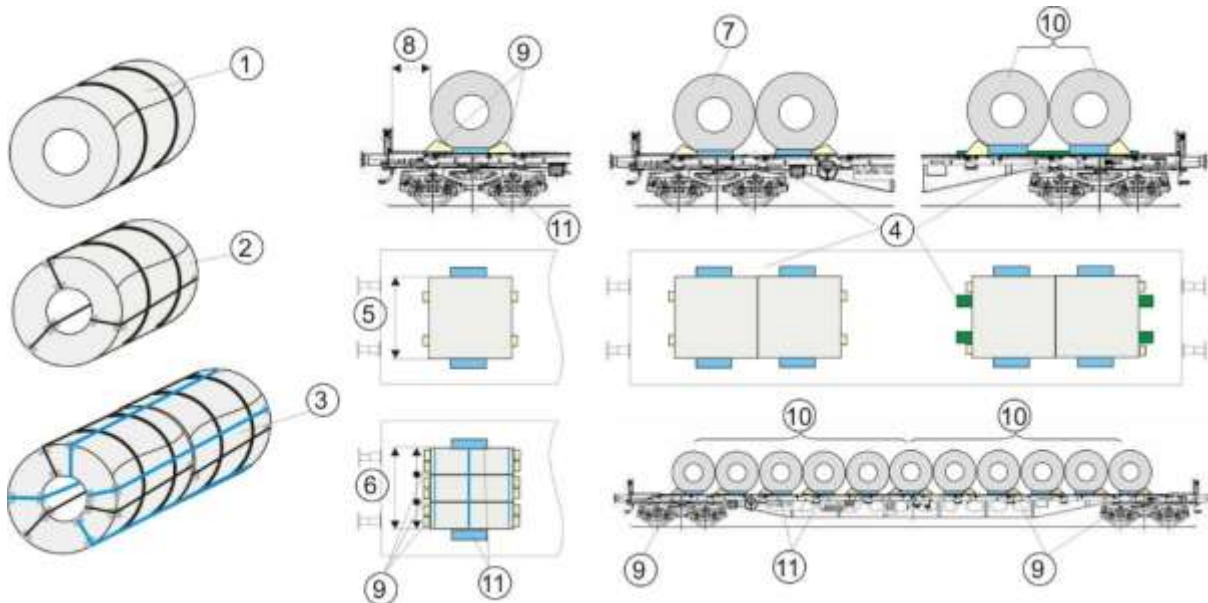

#### Securing

Lengthways in the wagon

- ⑨ each coil — even when several coils are bound to form one unit — shall be secured on either side by at least two scotches in each running direction.
- ⑩ Groups (max. 7 t) as shown in the diagram  
Scotch dimensions: minimum height 12 cm, minimum breadth 12 cm, angle of slope approx. 35°. Number of nails in the scotches on each side (total).

1 nail/500 kg of load

1 nail/2000 kg of load

Across the wagon

- ⑪ each coil shall be secured with stop scotches at least 5 cm thick and with at least 3 cm effective height.  
Number of nails in scotches on each side (total): 1 nail/1500 kg. At least two nails per scotch.

#### Additional indication

Load of wagons: see information sheet 0.1



## 1.3.2 Ungreased hot-rolled coiled sheet

Single wagons and groups of wagons

Wagons in block trains or combined transport  
Wagons with long-stroke shock absorbers

### Type of goods

- ① Coiled sheet loaded "eye-to-sky"
  - on the wagon floor, minimum diameter  $\frac{7}{10}$  of H
  - on wooden timbers, minimum diameter = H
- ② Coils bound with steel strips (breaking strength min. 1400 daN), at least
  - twice around the circumference **or**
  - once round the circumference and once through the mandrel hole **or**
  - three times through the mandrel hole and distributed as evenly as possible around the entire circumference.

### Wagons

Wagons with wooden floor.

### Method of loading

Sheet metal coils loaded:

- ③ - directly onto the wagon floor, distributed evenly crossways, **or else**
- ④ - on two softwood, timbers laid parallel to the longitudinal axis of the wagon (cross-section: approx. 5x12 cm) resting on the broader face. Spacing between these timbers should be  $\frac{7}{10}$  at least of the diameter of the coil.
- ⑤ - They should extend at least 30 cm beyond the sheet metal coils on each side.
- ⑥ - Minimum clearance: 50 cm

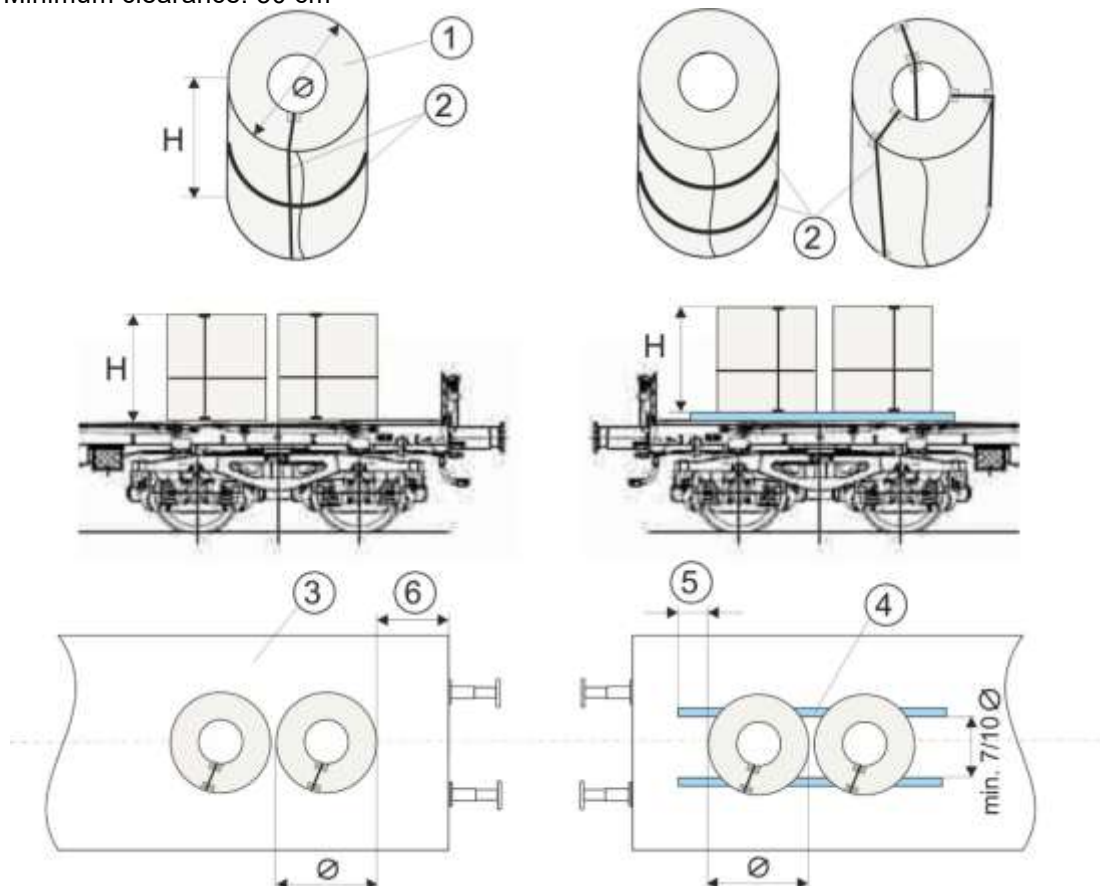

### Securing

No additional measures required.

### Additional indication

Load of wagons: see information sheet 0.1.



## 1.4.1 Steel pipes in tiers, diameter greater than 65 cm (26")

Single wagons and groups of wagons

Wagons in block trains or combined transport  
Wagons with long-stroke shock absorbers

### Type of goods

Steel pipes, various surfaces (with or without flanges)

### Wagons

Wagons with stanchions and wooden floor

### Method of loading

Pipes loaded directly onto the wagon floor, on bolsters or on timbers:

- ① - in one or more tiers, where possible over the full width of the wagon, with pipe centres vertically aligned.
  - ② - the number of tiers should be no greater than the number of pipes per tier (with a maximum of one tier dovetailed)
  - ③ - flanges or sleeves should not come into contact (load alternately).
  - ④ - pipes should extend beyond the timbers and bolsters by at least 50 cm.
  - ⑤ - minimum clearances
 

• for untreated pipes	30 cm		0 cm
• for greased or smooth-coated pipes	50 cm		0 cm
  - ⑥ - wooden timbers and bolsters should be made from healthy, undamaged wood as per standard EN 338, strength class C24 minimum, square-sawn from one piece, resting on the broader face without contact with the stanchions,
 

• with a rectangular cross-section of at least 90 cm <sup>2</sup> and a minimum thickness of 6 cm.				
• total cross-section of timbers per tier (cm <sup>2</sup> )	minimum	360	480	600
for a mass of pipes per tier (t)	maximum	10	15	20
  - ⑦ - number of timbers and lateral scotches
    - at least two for pipe lengths less than or equal to 12 m and a mass of up to 15 t per tier
    - four (in two pairs) for pipe lengths greater than 12 m and a mass greater than 15 t per tier
- Timbers fastened with at least four nails (diameter 5 mm, depth of penetration at least 40 mm)

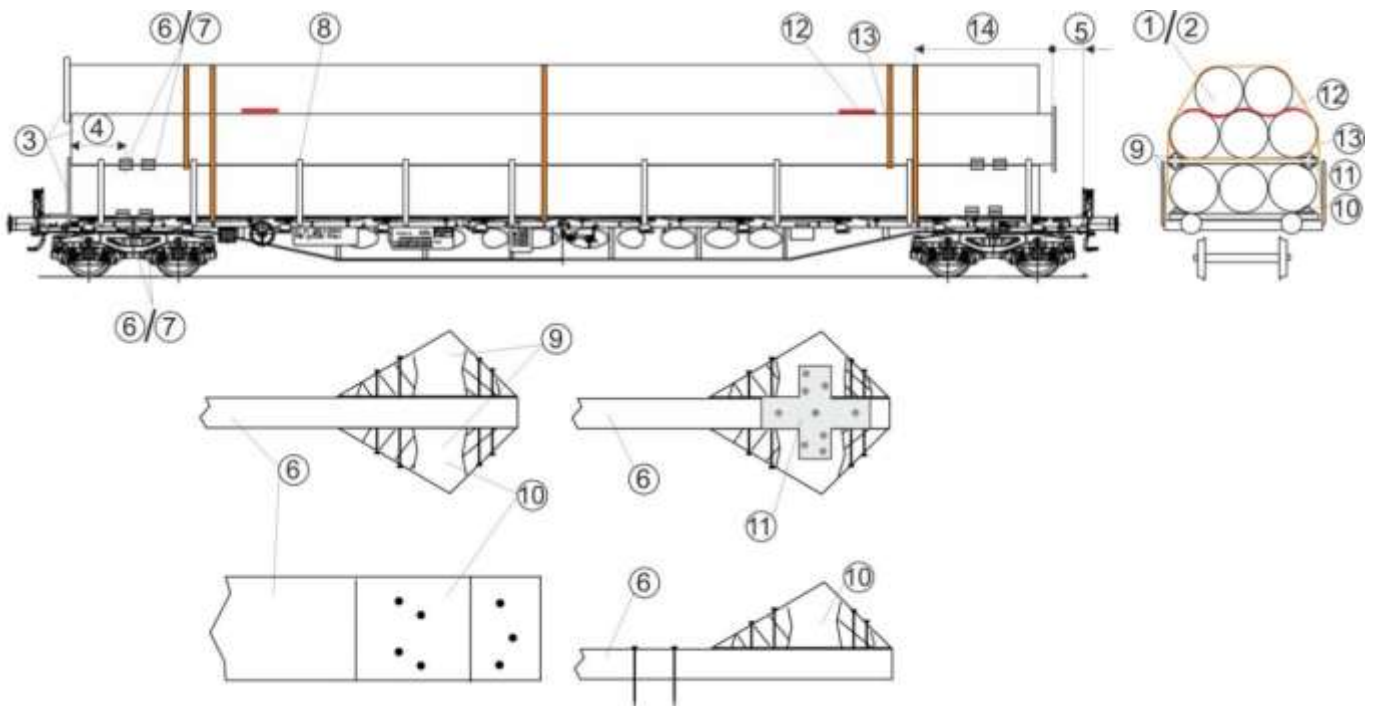

## 1.4.1

### Securing

- ⑧ - **All stanchions should be raised**
- ⑨ - Each tier of pipes should be secured with wooden scotches as shown (no clearances):
  - scotches attached to timbers facing upwards and downwards,
  - scotches should be the same width as the timbers and cross-timbers,
  - scotch height should be  $\frac{1}{12}$  of pipe diameter, though at least 12 cm; scotch angle approx. 35°,
- Scotches should be secured on both sides of the load
- ⑩
  - **between the stanchions** with nails (pipes secured by min. half their diameter) number of nails (diameter 5 mm) on each side: total of one per 1500 kg of load (i.e. tier to be secured, including dovetailed tier where appropriate); nails should be evenly spread, with at least four per scotch (two inside and two outside), should be driven in vertically and penetrate to a depth of at least 40 mm
- ⑪
  - **above the stanchions** (pipes protruding above the stanchions by more than half their diameter) as in ⑩ and with steel connecting plates 3 mm thick screwed to the timbers on both sides with wood screws; number of screws of at least 6 mm diameter and 60 mm length for each connecting plate: nine (three in each scotch and three in the timber)
- ⑫
  - Greased or smooth-coated pipes use friction inserts
- ⑬ - The dovetailed tier should be bound to the bearing tier beneath with at least two straps (breaking strength<sup>1)</sup> minimum 4000 daN)
- ⑭ When
  - pipes project beyond the stanchions by more than half a pipe diameter, **or**
    - the clearance is less than in ⑤ **or**
    - pipes are greased or smooth-coated
    - pipes are greased or smooth-coated and in the absence of friction inserts

Stack to be lashed down with straps with tensioning device (breaking strength<sup>1)</sup> at least 4000 daN); number: one strap for every 6 m of pipe length and at least two per stack (straps approx. 50 cm from the pipe ends).

### Additional indications

Load of wagons: see information sheet 0.1

Maximum dimensions of loads: see information sheet 0.2

Single-use bindings: see information sheet 0.6,

Indirect fastenings: see information sheet 0.7,

Friction and coefficients of friction: see information sheet 0.8.

For traffic destined for ADIF, the straps (indirect fastenings) must have built-in tensioning and locking devices.

<sup>1)</sup> The minimum breaking strength (straight pull) corresponds to double the permitted tensile force (LC); this concerns only synthetic straps, woven straps and load securing straps, as well as lashing steel wire ropes and lashing chains.

### 1.4.2 Steel pipes in tiers, diameter of over 40 cm up to 65 cm (16'' - 26'')

Single wagons and groups of wagons

Wagons in block trains or combined transport  
Wagons with long-stroke shock absorbers

#### Type of goods

Steel pipes, various surfaces (with or without flanges)

#### Wagons

Wagons with stanchions and wooden floor

#### Method of loading

Pipes loaded directly onto the wagon floor, on bolsters or on timbers:

- ① - in one or more tiers, where possible over the full width of the wagon, with pipe centres vertically aligned.
- ② - the number of tiers should be no greater than the number of pipes per tier (with a maximum of one tier dovetailed)
- ③ - flanges or sleeves should not come into contact (load alternately).
- ④ - pipes should extend beyond the timbers and bolsters by at least 50 cm.
- ⑤ - minimum clearances
 

• for untreated pipes	30 cm		0 cm
• for greased or smooth-coated pipes	50 cm		0 cm
- ⑥ Wooden timbers and bolsters should be made from healthy, undamaged wood as per standard EN 338, strength class C24 minimum, square-sawn from one piece, resting on the broader face without contact with the stanchions,
  - with a rectangular cross-section of at least 80 cm<sup>2</sup> and a minimum thickness of 6 cm.
  - total cross-section of timbers per tier (cm<sup>2</sup>)
 

minimum	240	360	480	
for a mass of pipes per tier (t)	maximum	10	15	20
- ⑦ - Number of timbers and lateral scotches
  - at least two for pipe lengths less than or equal to 12 m and a mass of up to 15 t per tier
  - four (in two pairs) for pipe lengths greater than 12 m and a mass greater than 15 t per tier
  - Timbers fastened with at least four nails (diameter 5 mm, depth of penetration at least 40 mm)

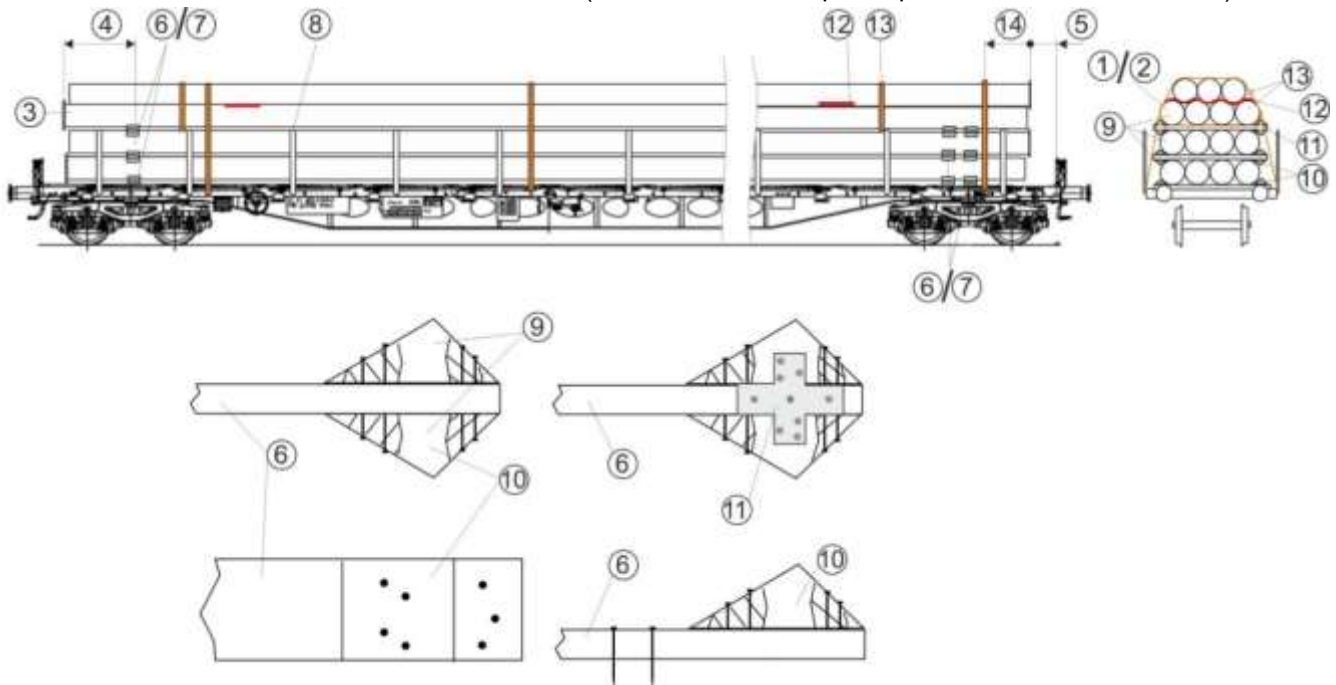

## 1.4.2

### Securing

- ⑧ - **All stanchions should be raised**
- ⑨ - Each tier of pipes should be secured with scotches as shown (no clearances):
  - scotches attached to timbers facing upwards and downwards,
  - scotches should be the same width as the timbers and cross-timbers,
  - scotch height should be at least 12 cm; scotch angle approx. 35°
- Scotches should be secured on both sides of the load
- ⑩
  - **between the stanchions** with nails (pipes secured by min. half their diameter) number of nails (diameter 5 mm) on each side: total of one per 1500 kg of load (i.e. tier to be secured, including dovetailed tier where appropriate); nails should be evenly spread, with at least four per scotch (two inside and two outside), should be driven in vertically and penetrate to a depth of at least 40 mm
- ⑪
  - **above the stanchions** (pipes protruding above the stanchions by more than half their diameter) as in ⑩ and with steel connecting plates 3 mm thick screwed to the timbers on both sides with wood screws; number of screws of at least 6 mm diameter and 60 mm length for each connecting plate: nine (three in each scotch and three in the timber)
- ⑫
  - Greased or smooth-coated pipes use friction inserts
- ⑬ - The dovetailed tier should be bound to the bearing tier beneath with at least two straps (breaking strength<sup>1)</sup> minimum 4000 daN)
- ⑭ When
  - pipes project beyond the stanchions by more than half a pipe diameter, **or**
    - the clearance is less than in ⑤ **or**
    - pipes are greased or smooth-coated
    - pipes are greased or smooth-coated and in the absence of friction inserts

Stack to be lashed down with straps with tensioning device (breaking strength<sup>1)</sup> at least 4000 daN). Number: one strap for every 6 m of pipe length and at least two per stack (straps approx. 50 cm from the pipe ends).

### Additional indications

Load of wagons: see information sheet 0.1

Maximum dimensions of loads: see information sheet 0.2

Single-use bindings: see information sheet 0.6,

Indirect fastenings: see information sheet 0.7,

Friction and coefficients of friction: see information sheet 0.8.

For traffic destined for ADIF, the straps (indirect fastenings) must have built-in tensioning and locking devices.

---

<sup>1)</sup> The minimum breaking strength (straight pull) corresponds to double the permitted tensile force (LC); this concerns only synthetic straps, woven straps and load securing straps, as well as lashing steel wire ropes and lashing chains.

### 1.4.3 Steel pipes in tiers, diameter of over 25 and up to 40 cm (10'' - 16'')

Single wagons and groups of wagons

Wagons in block trains or combined transport  
Wagons with long-stroke shock absorbers

#### Type of goods

Steel pipes, various surfaces (with or without flanges)

#### Wagons

Wagons with stanchions and wooden floor

#### Method of loading

Pipes loaded directly onto the wagon floor, on bolsters or on timbers:

- ① - in one or more tiers, where possible over the full width of the wagon, with pipe centres vertically aligned.
  - ② - the number of tiers should be no greater than the number of pipes per tier (with a maximum of one tier dovetailed)
  - ③ - flanges or sleeves should not come into contact (load alternately).
  - ④ - pipes should extend beyond the timbers and bolsters by at least 50 cm.
  - ⑤ - minimum clearances
 

• for pipes with untreated surface	30 cm		0 cm
• for greased or smooth-coated pipes	50 cm		0 cm
  - ⑥ - wooden timbers and bolsters should be made from healthy, undamaged wood of the highest grade, in accordance with standard EN 338, strength class C24 minimum, square-sawn from one piece, resting on the broader face without contact with the stanchions,
    - with a rectangular cross-section of at least 70 cm<sup>2</sup> and a minimum thickness of 5 cm.
    - total cross-section of timbers per tier (cm<sup>2</sup>)
 

minimum	180	210	240
---------	-----	-----	-----
    - for a mass of pipes per tier (t)
 

maximum	9	12	15
---------	---	----	----
  - ⑦ - number of timbers and lateral scotches
    - at least two for pipe lengths less than or equal to 12 m and a mass of up to 15 t per tier
    - four (in two pairs) for pipe lengths greater than 12 m and a mass greater than 15 t per tier
- timbers fastened with at least four nails (diameter 5 mm, depth of penetration at least 40 mm)

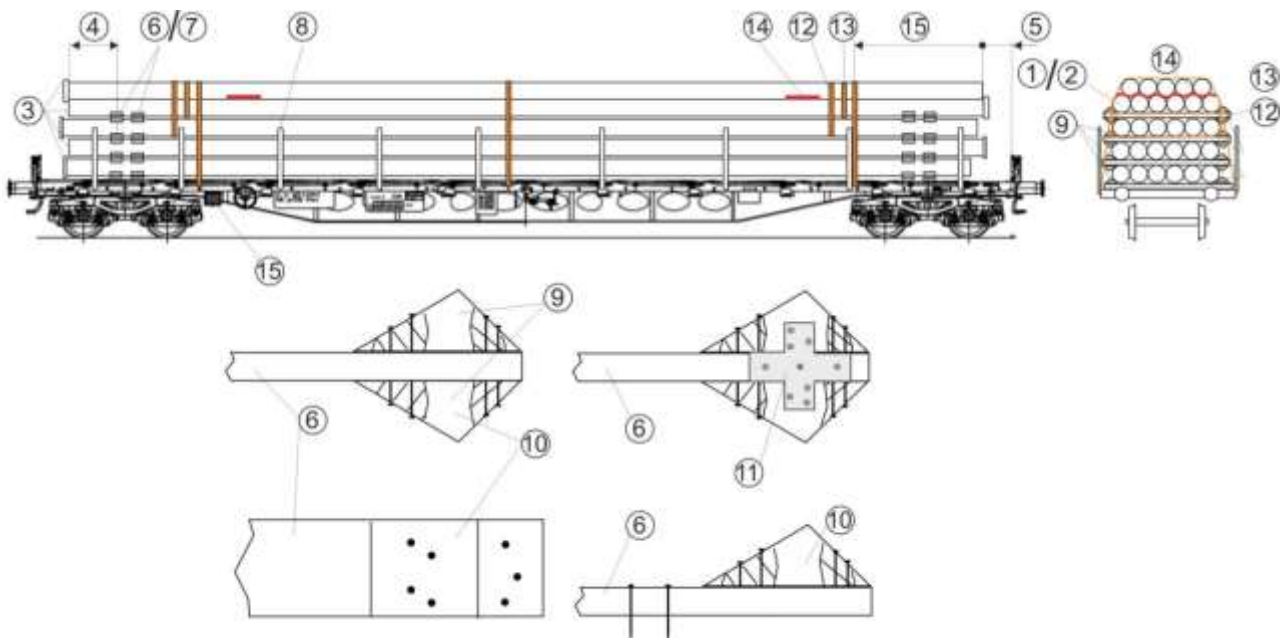

### 1.4.3

#### Securing

- ⑧ - **All stanchions should be raised**
- ⑨ - Each tier of pipes should be secured with scotches as shown (no clearances):
  - scotches attached to timbers facing upwards and downwards,
  - scotches should be the same width as the timbers and cross-timbers,
  - scotch height should be at least 12 cm; scotch angle approx. 35°,
- Scotches should be secured on both sides of the load
- ⑩
  - **between the stanchions**  
with nails  
number of nails (diameter 5 mm) on each side: total of one per 1500 kg of load (i.e. tier to be secured, including dovetailed tier where appropriate); nails should be evenly spread, with at least four per scotch (two inside and two outside), should be driven in vertically and penetrate to a depth of at least 40 mm
  - **above the stanchions** (pipes protruding above the stanchions by more than half their diameter) and with
    - ⑪ ○ steel connecting plates as in ⑩ 3 mm thick screwed to the timbers on both sides with wood screws; number of screws of at least 6 mm diameter and 60 mm length for each connecting plate: nine (three in each scotch and three in the timber) or
    - ⑫ ○ nails as in ⑩ and with the protruding pipes bound with straps or bands (breaking strength<sup>1)</sup> at least 3000 daN) to the tier secured by the stanchions; number: one for every 6 m pipe length, at least two per stack
- ⑬ - The dovetailed tier should always be bound to the bearing tier beneath
- ⑭
  - greased or smooth-coated pipes:  
use friction inserts
- ⑮ When
  - pipes project beyond the stanchions by more than half a pipe diameter, **or**
    - when the clearance is less than in ⑤ **or**
    - pipes are greased or smooth-coated
    - when pipes are greased or smooth-coated and in the absence of friction inserts

Stack to be lashed down with straps with tensioning device (breaking strength<sup>1)</sup> at least 3000 daN), one strap for every 6 m of pipe length and at least two per stack (straps approx. 50 cm from the pipe ends) under the following conditions

#### Additional indications

Load of wagons: see information sheet 0.1

Maximum dimensions of loads: see information sheet 0.2

Single-use bindings: see information sheet 0.6,

Indirect fastenings: see information sheet 0.7,

Friction and coefficients of friction: see information sheet 0.8.

For traffic destined for ADIF, the straps (indirect fastenings) must have built-in tensioning and locking devices.

<sup>1)</sup> The minimum breaking strength (straight pull) corresponds to double the permitted tensile force (LC); this concerns only synthetic straps, woven straps and load securing straps, as well as lashing steel wire ropes and lashing chains.

## 1.4.4 Steel pipes in dovetailed stacks, resting on the stanchions

Single wagons and groups of wagons

Wagons in block trains or combined transport  
Wagons with long-stroke shock absorbers

### Type of goods

Steel pipes of any type of surface.

### Wagon

Wagon with stanchions and wooden floor

### Method of loading

Pipes should be loaded as follows:

- ① - bottom tier placed directly on the wagon floor, on bolsters or timbers, closely-packed across the full width of the wagon (space filling)
- ② - upper tiers dovetailed, with the diameter of the dovetailed pipes less than or equal to that of pipes in the bearing tier, loaded above the stanchions to a maximum of  $\frac{1}{3}$  the width of the load (approx. 90 cm)
- ③ - pipes should extend beyond the wooden timbers by at least 50 cm
- ④ - timbers should be of healthy, undamaged wood of rectangular cross-section, resting on the broader face and not in contact with the stanchions
- ⑤ - minimum clearances
 

• for pipes with untreated surface	30 cm	0 cm
• for greased or smooth-coated pipes	50 cm	0 cm
- ⑥ - When pipes rest more than half way up the stanchions:
  - stanchions should be linked by double 4 mm wire or straps (minimum breaking strength<sup>1)</sup> 1000 daN), at the tip in the case of swivelling stanchions or
  - swivelling stanchions should be scotched.

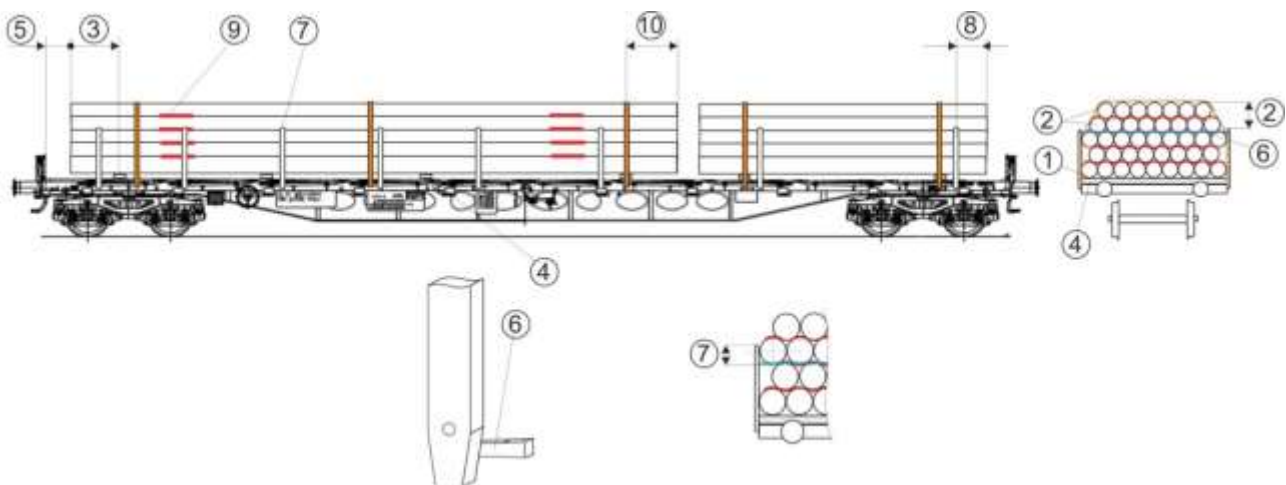

<sup>1)</sup> The minimum breaking strength (straight pull) corresponds to double the permitted tensile force (LC); this concerns only synthetic straps, woven straps and load securing straps, as well as lashing steel wire ropes and lashing chains.

#### 1.4.4

#### Securing

- ⑦ - all stanchions should be raised  
(pipes leaning against stanchions must be supported over at least  $\frac{1}{2}$  their diameter)
- ⑧ - pipes secured by only two stanchions must extend beyond the stanchions by at least:
- |                                      |       |  |       |
|--------------------------------------|-------|--|-------|
| • for pipes with untreated surface   | 30 cm |  | 20 cm |
| • for greased or smooth-coated pipes | 50 cm |  | 30 cm |
- ⑨ - greased or smooth-coated pipes  
use friction inserts
- ⑩ - Stacks to be lashed down with straps or bands (breaking strength<sup>1</sup>) at least 3000 daN), one for every 6 m of pipe length, at least two per stack, distance from pipe ends approx. 50 cm
- |   |  |
|---|--|
| • if the pipes project above the stanchions by more than half their diameter, <b>or</b> |  |
| • if the clearance is less than in ⑤ <b>or</b>  | • when pipes are greased or smooth-coated and in the absence of friction inserts |
| • when pipes are greased or smooth-coated   |  |

#### Additional indications

Load of wagons: see information sheet 0.1

Maximum dimensions of loads: see information sheet 0.2

Single-use bindings: see information sheet 0.6,

Indirect fastenings: see information sheet 0.7,

Friction and coefficients of friction: see information sheet 0.8.

For traffic destined for ADIF, the straps (indirect fastenings) must have built-in tensioning and locking devices.

## 1.4.5 Steel pipes in dovetailed stacks, laterally scotched

Single wagons and groups of wagons

Wagons in block trains or combined transport  
Wagons with long-stroke shock absorbers

### Type of goods

Steel pipes of any type of surface.

### Wagon

Wagon with stanchions and wooden floor

### Method of loading

Pipes should be loaded as follows:

- ① - bottom tier placed directly on the wagon floor, on bolsters or timbers, closely-packed against one another
- ② - max. three tiers dovetailed (i.e. four tiers in all)  
the diameter of the dovetailed pipes should be less than or equal to that of pipes in the bearing tier
- ③ - pipes should extend beyond the wooden timbers by at least 50 cm
- ④ - minimum clearances
 

• for pipes with untreated surface	30 cm	0 cm
• for greased or smooth-coated pipes	50 cm	0 cm
- ⑤ - timbers should be of healthy, undamaged wood in accordance with standard EN 338, strength class C24 at least, square-sawn and of one piece, of rectangular cross-section, resting on the broader face and not in contact with the stanchions; at least 6 cm thick and fastened with four nails (diameter 5 mm, depth of penetration at least 40 mm)
- ⑥ - number of scotches, on timbers as appropriate
  - two for pipe length up to 12 m and 15 t weight per tier
  - four (in two pairs) for pipe length over 12 m and weight over 15 t per tier

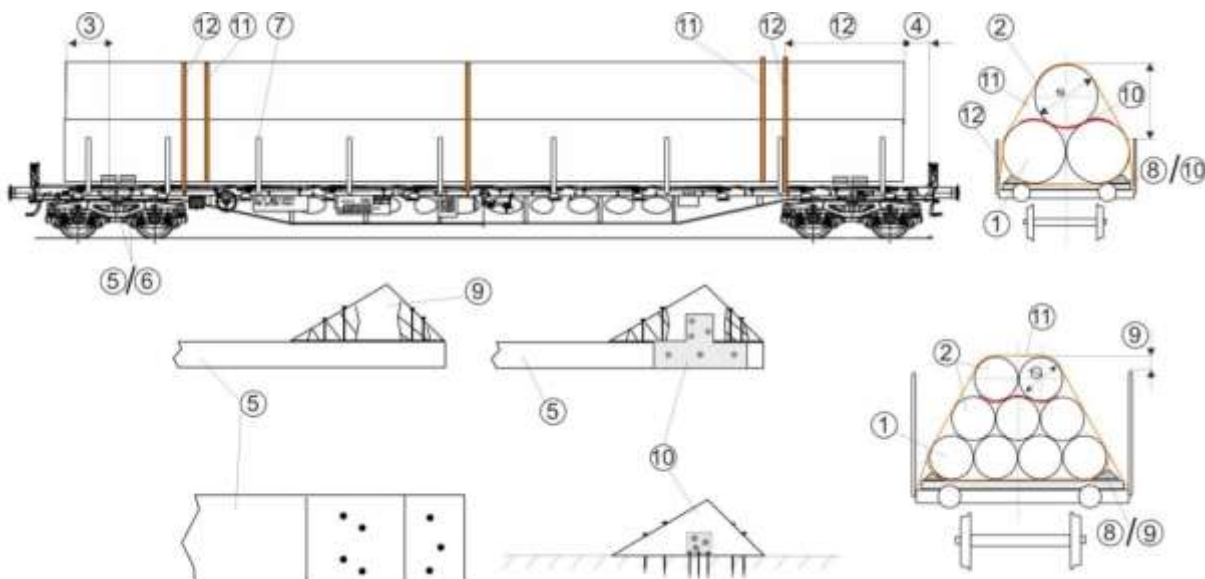

## 1.4.5

### Securing

- ⑦ - **All stanchions should be raised**
- ⑧ - Each tier of pipes should be secured with wooden scotches (no clearances):
  - scotches should be the same width as the timbers and cross-timbers,
  - scotch height  $\frac{1}{12}$  of pipe diameter, though at least 12 cm; scotch angle approx. 35°,
- Scotches should be secured on both sides of the load
- ⑨
  - **on stacks that do not project above the stanchions** by more than half a pipe diameter with nails  
number of nails (diameter 5 mm) on each side: total of one per 1500 kg of load (taken in relation to the total mass of the load); nails should be evenly spread, with at least four per scotch (two inside and two outside), should be driven in vertically and penetrate to a depth of at least 40 mm
- ⑩
  - **on stacks that project above the stanchions** by more than half a pipe diameter with nails and steel connecting plates 3 mm thick screwed to the wagon floor / timbers with wood screws; number of screws of at least 6 mm diameter and 60 mm length for each connecting plate: six (three in the scotches and three in the timbers)
  - stacks weighing over 30 t should be secured using nailed scotches as in ⑨ and screwed down connecting plates
  - greased or smooth-coated pipes  
use friction inserts
- ⑪ - dovetailed tiers should be bound together with the bearing tier beneath at least twice using straps with tensioning device (breaking strength<sup>1)</sup> at least 4000 daN)
- ⑫ - Stacks to be lashed down with straps with tensioning device (breaking strength<sup>1)</sup> at least 4000 daN), one strap for every 6 m of pipe length and at least two per stack (straps approx. 50 cm from the pipe ends)

#### When

- pipes project beyond the stanchions by more than half a pipe diameter, **or**
  - the clearance is less than in ④ **or**
  - when pipes are greased or smooth-coated
  - when pipes are greased or smooth-coated and in the absence of friction inserts

### Additional indications

Load of wagons: see information sheet 0.1

Maximum dimensions of loads: see information sheet 0.2

Single-use bindings: see information sheet 0.6,

Indirect fastenings: see information sheet 0.7,

Friction and coefficients of friction: see information sheet 0.8.

For traffic destined for ADIF, the straps (indirect fastenings) must have built-in tensioning and locking devices.

<sup>1)</sup> The minimum breaking strength (straight pull) corresponds to double the permitted tensile force (LC); this concerns only synthetic straps, woven straps and load securing straps.

## 1.4.6 Steel pipes, dovetailed on special wagons

Single wagons and groups of wagons

Wagons in block trains or combined transport  
Wagons with long-stroke shock absorbers

### Type of goods

Steel pipes of any surface.

### Wagons

Wagons with strengthened side<sup>1)</sup> stanchions and indirect securing straps (Sp..., Roo...)

### Method of loading

Before loading, the position and mass of steel pipes, as well as the forces exerted on the stanchions, are to be taken into consideration.

Pipes should be loaded as follows:

- ① - pipes with small diameter: along the bottom layer, very close together (loading gap on one side)
- ② - pipes with larger diameter: against the stanchions on both sides (loading gap in the centre),
- ③ - pipes on the top layer and which rest against the stanchions must not project above them by more than half their diameter,
- ④ - above the stanchions, pipes should be dovetailed and arranged as symmetrically as possible
- ⑤ - Dovetailing should only be used when the pipes forming the base are at the same height.
- ⑥ For Sp... wagons: minimum clearances

• for pipes with untreated surface	30 cm	0 cm
• for greased or smooth-coated pipes	50 cm	0 cm

For Roo... wagons: no clearance required.

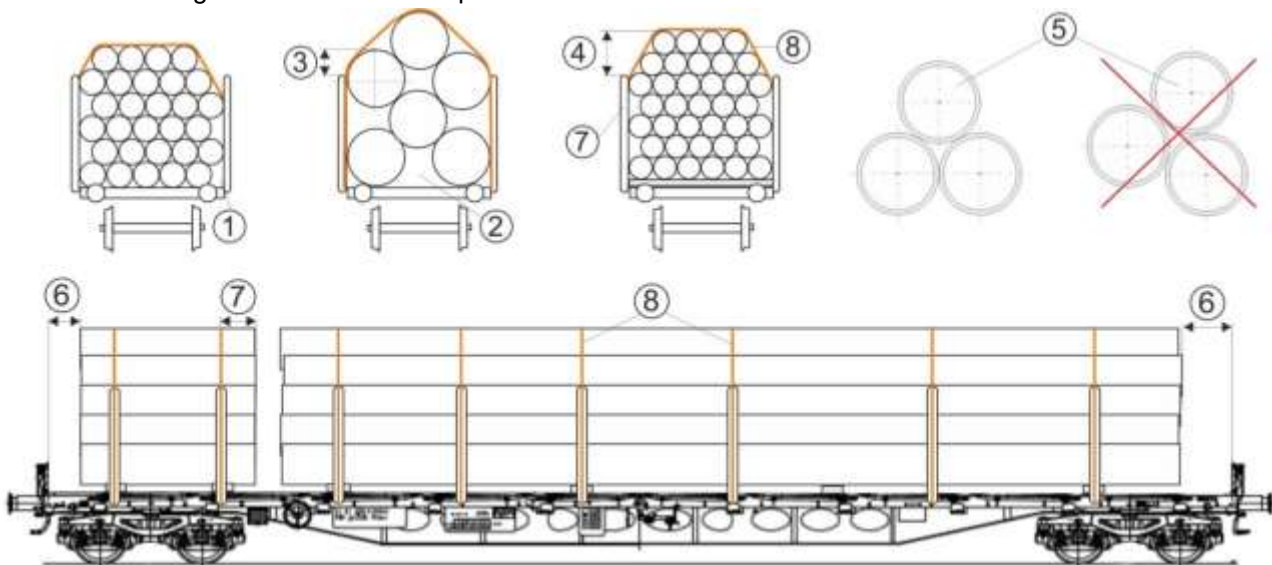

### Securing

- ⑦ - by side stanchions, when secured by only two stanchions on each side, pipes must extend beyond the centre of the stanchion by at least:
 

• for pipes with untreated surface	30 cm	20 cm
• for greased or smooth-coated pipes	50 cm	30 cm
- ⑧ - Stacks should be lashed down using all the fastenings fitted to the wagon; short stacks: at least twice

### Additional indications

Load of wagons: see information sheet 0.1

Maximum dimensions of loads: see information sheet 0.2

<sup>1)</sup> Wagons with strengthened stanchions according to the UIC leaflet 577, 4.4.3 are marked "II" or are mentioned in the list appearing in the loading method 100.3.



## 1.4.7 Steel tubes/pipes, bars and polygonal sections bound into bundles

Single wagons and groups of wagons

Wagons in block trains or combined transport  
Wagons with long-stroke shock absorbers

### Type of goods

Steel tubes/pipes, bars and polygonal sections bound into bundles.

Number of bindings per diameter, length and weight of bundle:

one binding per 3 m of bundle length, at least two bindings per bundle. Distance of bindings from bundle ends: 30 cm approx.

Breaking strength<sup>1)</sup> of bindings: min. 1400 daN, binding pulled tight to be effective.

Synthetic and woven straps should only be used on sharp edges with edge protection.

### Wagons

Wagons with stanchions and end boards.

### Method of loading

- ① Bundles loaded side by side directly onto the wagon floor, on bolsters or on wooden timbers. Timbers should be soft wood, of rectangular cross-section resting on the broader face.
- ②③ On the bottom layer, bundles are in contact with the stanchions **or**
- ④ loaded in the centre in case of single-layer loading which does not take up the full width available
- On the upper layer, bundles are:
  - ⑤ - dovetailed. To facilitate transhipment, they may be separated using inserts placed either at an angle or vertically.
  - ⑥ - stacked. Bundles with the same height should be loaded into layers. If bundles of different heights are loaded together, then these height differences must be compensated via the timbers <sup>Ⓐ</sup> by means of suitable, interlocking pieces of wood. Max. load height  $L_{hmax}$  = height of the stanchions (bundles secured to at least half of their height by the stanchions)
- ⑦ Minimum clearances for bundles above the end boards:

50 cm

30 cm

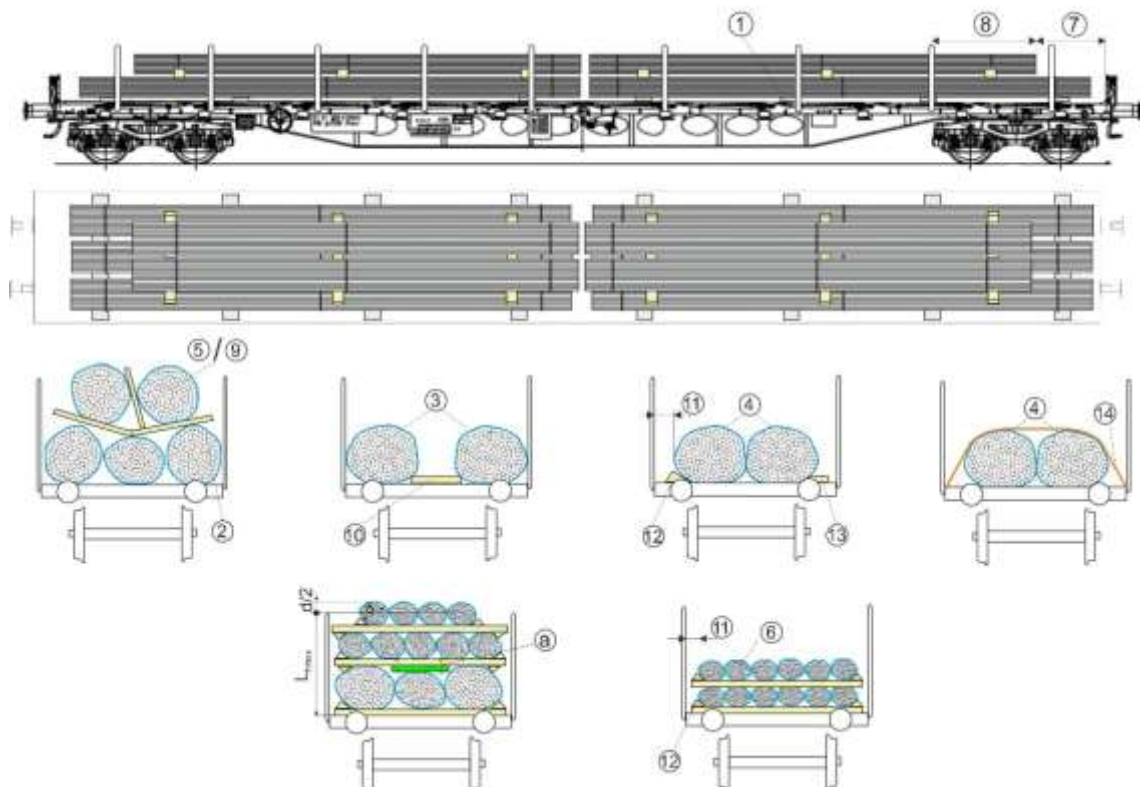

<sup>1)</sup> Minimum breaking strength in tangent traction is equivalent to twice the permissible traction strength (LC) and only applies to synthetic straps, woven straps and load-securing straps, as well as lashing steel wire ropes and lashing chains.

## 1.4.7

### Securing

- ⑧ by side stanchions (bottom layer); when secured by only two stanchions on each side, the load must extend lengthways beyond the centre of the stanchions by at least:

50 cm



30 cm

- ⑨ by a dovetailing arrangement (upper layer).
- ⑩ For loading in accordance with ③: empty spaces shall be filled with nailed timber pieces. Height of timber pieces: 5 cm min.
- ⑪ For loading in accordance with ④:
- no additional securing is required, where direct support is provided by boards, walls or stanchions (lateral distance  $\leq 10$  cm), no additional securing is required,
  - with lateral securing, where lateral distance is  $> 10$  cm.
- ⑫ - by scotches.  
Scotch dimensions:
- Height: min. 12 cm,
  - Width: min. 8 cm,
  - Scotch angle: approx.  $35^\circ$ .
- Number of nails in the scotches, on each side of the load: at least one nail per 1500 kg of load mass, with at least two nails per scotch,
- or**
- ⑬ - by timber pieces: min. height 5 cm, secured to the wagon floor with one nail per 1500 kg of load mass, at least two nails per scotch. Nail diameter: min. 5 mm or threaded nail: minimum 4.2 mm. Penetration depth into wagon floor: min. 40 mm, **or**
- ⑭ - by indirect fastening with synthetic or woven straps, should only be used on sharp edges with edge protection (breaking strength<sup>1)</sup> min. 2800 daN), one indirect fastening per 3 m section or part thereof, at least two per stack.

### Additional indications

Load of wagons: see information sheet 0.1,  
Single-use bindings: see information sheet 0.6,  
Indirect fastenings: see information sheet 0.7.

---

<sup>1)</sup> Minimum breaking strength in tangent traction is equivalent to twice the permissible traction strength (LC) and only applies to synthetic straps, woven straps and load-securing straps, as well as lashing steel wire ropes and lashing chains.

## 1.5.1 Wheelsets

Single wagons and groups of wagons

Wagons in block trains or combined transport  
Wagons with long-stroke shock absorbers

### Type of goods

Wheelsets with or without axle boxes

### Wagons

Wagons with walls or collapsible boards and wooden floors

### Method of loading

Wheelsets loaded lengthways along the wagon on wooden cradles using approximately the entire width of the load

- ① - individually with an individual cradle for each wheel **or**
- ② - in groups on group cradles, the wheelsets must not be allowed to roll on the cradles,
  - the cradles must be in perfect technical condition.
- ③ - clearances across the wagon: 20 cm min.,
  - clearances along the length of the wagon:
- ④
  - between wheelsets: 20 cm min.,
- ⑤
  - vis-à-vis the walls or collapsible end boards

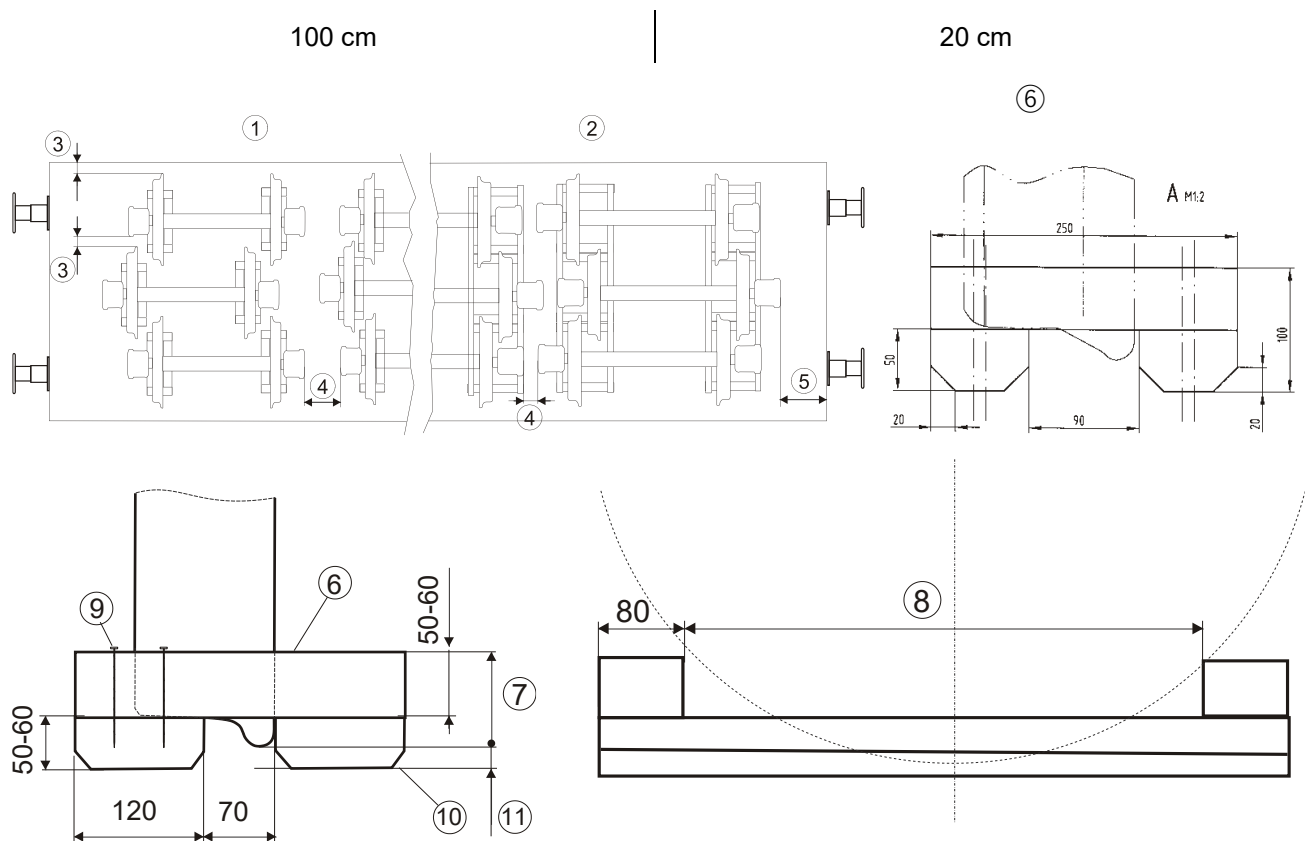

### Securing

- ⑥ on wooden cradles
- ⑦ - effective height: 80 mm min.,
- ⑧ - the length of the cradle must be suited to the wheel diameter. For wheel diameters ranging between 840 and 920 mm, the cradle length is 510 mm.
- ⑨ - assembled using M 10 countersunk head bolts or 5 x 100 mm screw nails
- ⑩ - chamfered in the longitudinal direction of the wagon
- ⑪ - wheelsets may not rest on the wagon floor.

### Additional indication

Load of wagons: see information sheet 0.1.



## 1.5.2 Wheelset rubber support pads

Single wagons or group of wagons

Wagons in block trains or combined transport  
Wagons with long-stroke shock absorbers

### Type of goods

Wheelsets with or without axle-box, loaded on rubber support pads (in order not to damage the rubber support pads, the wheelset should have only slight side projection)

### Wagons

With walls or collapsible boards and wooden floors

### Method of loading

Wheelsets loaded “gunshot” on rubber support pads. The support pad adjusts to the wheel diameter with two support plates.

Integrated magnets keep the support pad in place on the wheel (e. g. for transshipment).

- ① - Individually with one support pad per wheel **or**
- ② - For several wheels with twin support pads, the wheelsets should be prevented from rolling;
  - the support pads should be in perfect technical condition.
- ③ - Clearances seen at a right angle to the longitudinal axis of the wagon: min. 20 cm
- Clearances parallel to the longitudinal axis of the wagon
- ④ • between wheelsets: min. 20 cm
- ⑤ • In relation to walls or end boards

70 cm

20 cm

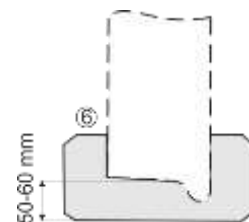
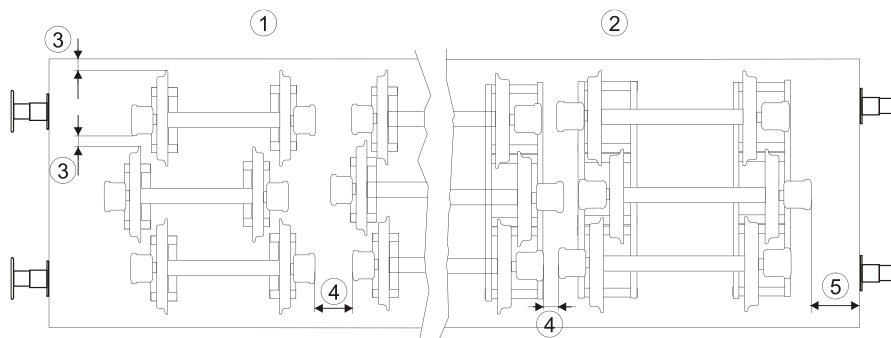

### Securing

- Through friction between the rubber support pad and the wagon floor
- ⑥ - Effective height: min. 60 cm
- Wheelsets: The running surface makes contact with the support pad at two points, the flange is not in contact with the support pad.

### Additional indications

Load of wagons see information sheet 0.1.

Friction and coefficients of friction see information sheet 0.8.

Strength requirement, resistance to high temperatures, see table 1

## 1.5.2

## Wheelset support pads

## Technical data sheet

CHARACTERISTICS	STANDARD	UNITS	VALUES
Colour			Black
Polymer			SBR
Density	DIN 53479	mg/dm <sup>3</sup>	1.2
Durability	DIN 53505	ShA	80
Yield stress	DIN 53504 S1	N/mm <sup>2</sup>	6
Elongation at break	DIN 53504 S1	%	76
Ozone resistance (20%, 20pphm, 24hr, 40°C)	DIN 53509		OK
Permanent deformation after 24hr compression 70°C 25 % deformation	DIN 53517	%	50
Abrasion	DIN 53516	mm <sup>3</sup>	100
Resistance to ageing	DIN 53508	°C	OK
Resistance to oils and grease	DIN 53521		Medium
Low-temperature behaviour	DIN 65467	°C	- 35°C

### 1.5.3 One or several bogies with wheelsets (rubber support pads)

Single wagons or group of wagons

Wagons in block trains or combined transport  
Wagons with long-stroke shock absorbers

#### Type of goods

One or several bogies with wheelsets weighing less than or equal to 18 tonnes, with wheels of between 640 and 1050 mm in diameter and  $\geq 125$  mm in width, loaded on rubber support pads for wheelsets (in order not to damage the rubber support pads, the wheels should have only slight side projection)

#### Wagons

Wagons with sides and wooden floor

#### Method of loading

- ① The rubber support pads are kept in place on the wheel by magnets (e.g. for transshipment).
- ② The bogie on the longitudinal axis of the wagon loaded on rubber support pads for wheelsets
  - must have a free space of at least 20 cm to the end wall or another bogie
  - must be covered with a single or multiple-use tarpaulin if required

#### Securing

- Securing equipment as per table

Weight Bogie	Load securing straps per side	Minimum breaking strength  Straight pull <sup>1)</sup>
Up to 9 t	2	8000 daN
Up to 13 t	2	10000 daN
Up to 18 t	2	16000 daN

Weight Bogie	Load securing straps per side	Minimum breaking strength  Straight pull <sup>1)</sup>
Up to 9 t	2	4000 daN
Up to 13 t	2	5000 daN
Up to 18 t	2	8000 daN

- ③ - Examples of securing options:

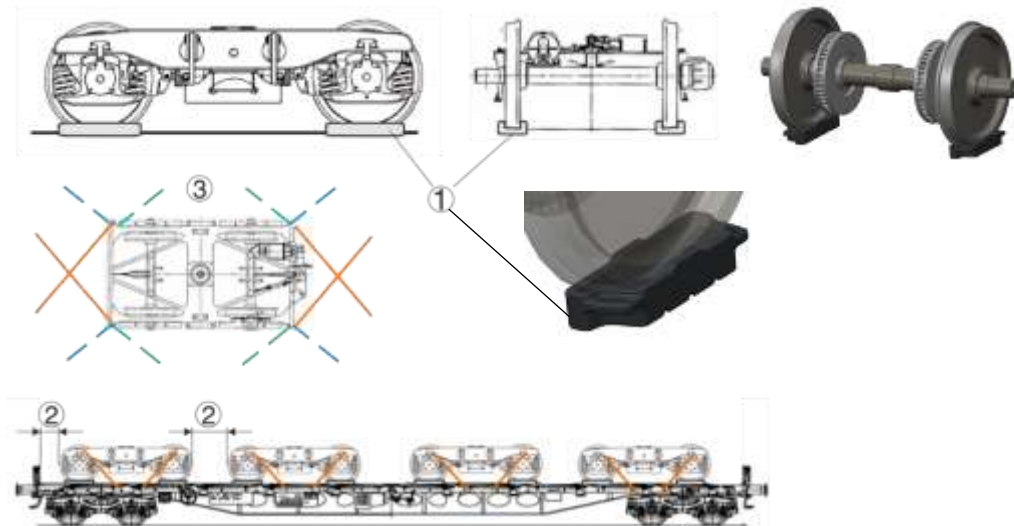

#### Additional indications

- Load of wagons: see information sheet 0.1
- Maximum dimensions of loads: see information sheet 0.2
- Covering of loads: see information sheet 0.3
- Single-use bindings: see information sheet 0.6
- Indirect fastenings: see information sheet 0.7

<sup>1)</sup> The minimum breaking strength (straight pull) corresponds to double the permitted tensile force (LC); this concerns only synthetic straps, woven-fabric straps and load securing straps, as well as lashing steel wire ropes and lashing chains.

## Wheelset support pads

## Technical data sheet

CHARACTERISTICS	STANDARD	UNITS	VALUES
Colour			Black
Polymer			SBR
Density	DIN 53479	mg/dm <sup>3</sup>	1.2
Durability	DIN 53505	ShA	80
Yield stress	DIN 53504 S1	N/mm <sup>2</sup>	6
Elongation at break	DIN 53504 S1	%	76
Ozone resistance (20%, 20pphm, 24hr, 40°C)	DIN 53509		OK
Permanent deformation after 24hr compression 70°C 25 % deformation	DIN 53517	%	50
Abrasion	DIN 53516	mm <sup>3</sup>	100
Resistance to ageing	DIN 53508	°C	OK
Resistance to oils and grease	DIN 53521		Medium
Low-temperature behaviour	DIN 65467	°C	- 35°C

## 1.6.1 Sections (ungreased)

Single wagons and groups of wagons

Wagons in block trains or combined transport  
Wagons with long-stroke shock absorbers

### Type of goods

- ① Sections in bulk **or**
- ② Sections bound into rectangular or trapezoid bundles, with steel strips bindings, annealed steel wire, synthetic straps with edge protection, straight pull breaking strength<sup>1)</sup> of bindings and their connecting parts at least 1400 daN
  - Bindings are to be positioned at intervals of max. 3 m between
  - Bindings are to be positioned approx. between 30 and 100 cm from the ends of the bundles.
  - Two bindings minimum per bundle

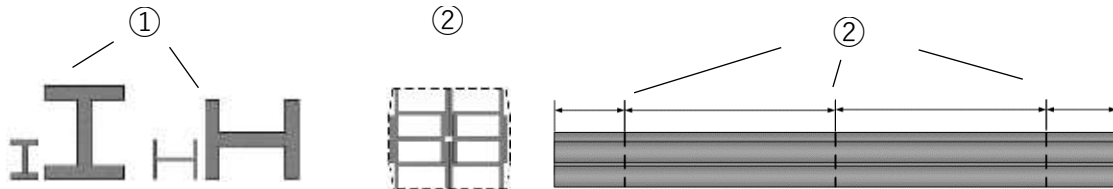

### Wagons

Wagons with walls, sides or stanchions and wooden floor and/or wooden/lined with wood bolsters.

### Method of loading

Sections and bundles should be loaded

- directly onto the wagon floor/on bolsters **or**
  - on wooden supporting scotches resting onto the wagon floor/on bolsters,
  - where possible across the effective width of the wagon.
- ③ - in one or several separate layers, wooden supporting scotches and timbers distributed over the effective width of the wagon or exceeding the width of the top layer of the load transversely but not exceeding the outer face of the stanchion **or**
  - ④ - stacked and resting one on top of another and/or dovetailed.

Supporting scotches and timbers

- made of sound, untreated wood in accordance with EN 338, strength class at least C24
  - cut in such a way as to ensure that all the edges of the wood used are sharp,
  - dimensions and quantity in accordance with purpose of use.
- ⑤ - Timbers of square or rectangular cross-section, resting on the broader face
  - ⑥(a) - maximum in three pieces, overlapping sideways and adequately bound (e.g., by nails, by penetrating dowels, by wire, ....), covering the full width of the load or load unit:
    - ⑥(b) - If supporting scotches or timbers in pairs are used, they should be secured against movement **or**
    - ⑥(c) - a longitudinal distance of at least 1.5 m must be maintained between two timbers/supporting scotches.
  - ⑦ Sections and bundles should extend beyond the timbers/the supporting scotches one the longitudinal axis of the wagon by at least

50 cm

30 cm

<sup>1)</sup> The minimum breaking strength (straight pull) corresponds to double the permitted tensile force (LC); this concerns only synthetic straps, woven-fabric straps and load securing straps, as well as lashing steel wire ropes and lashing chains

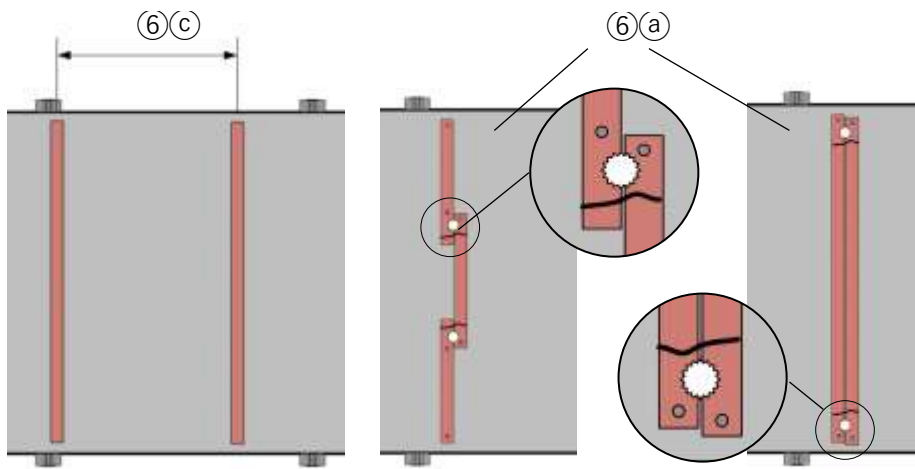
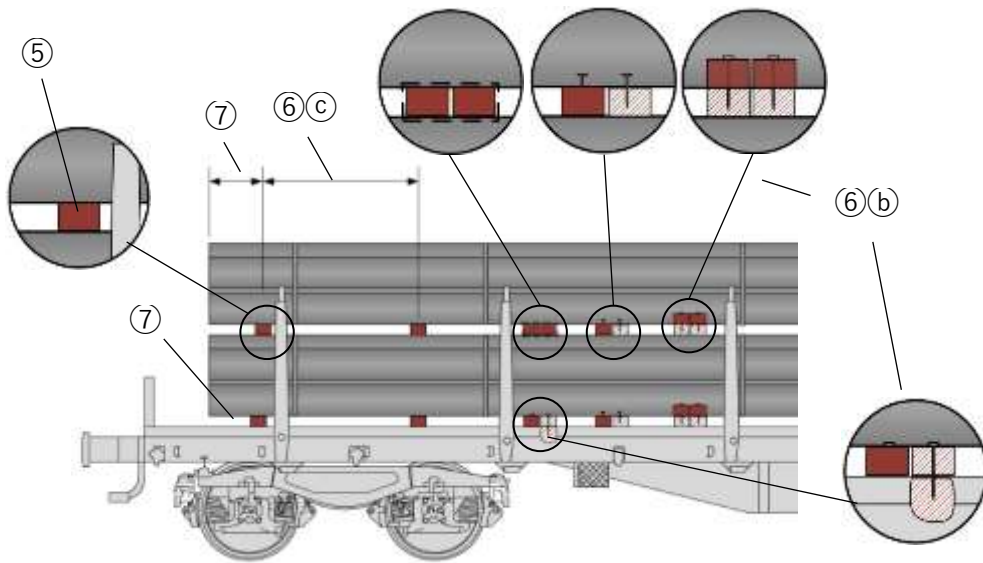
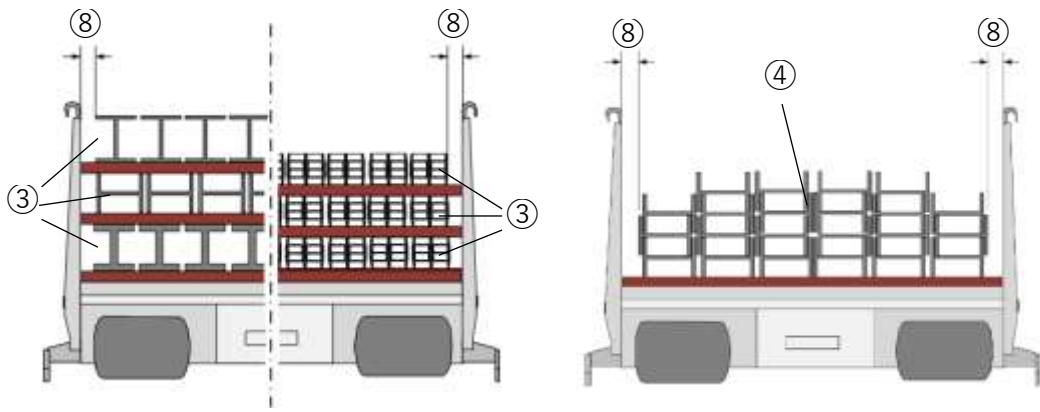

## Securing

Straight pull breaking strength<sup>1)</sup> of bindings and their connecting parts:

- Indirect fastening: 2800 daN
- Bound together: 1400 daN
- Fastening in opposite direction (loop lashings): 2800 daN, use only fastenings with tensioning device

Wooden guide-pieces should be at least 5 cm thick with an effective height of at least 3 cm, fixed with one nail/1500 kg of load and at least two nails per guide-piece.

- min. diameter of 5 mm
- penetration depth min. 40 mm

- ⑧ Sections and bundles loaded at a distance  $\leq 10$  cm should be secured directly by the walls, sides or stanchions
- without additional securing/bindings
  - with a width/height ratio  $< \frac{5}{10}$ , resting on their narrow base, secured against tipping
- ⑨
- resting on the edges, up to their centre of gravity by the height of the walls, sides or stanchions **or**
- ⑩
- resting on the flange, and the highest point extending beyond the height of the walls, sides or stanchions, one binding pulled tight per 6 m length, at least two bindings per length of sections/bundles; outer bindings between 50 and 100 cm from the ends of the sections/bundles.

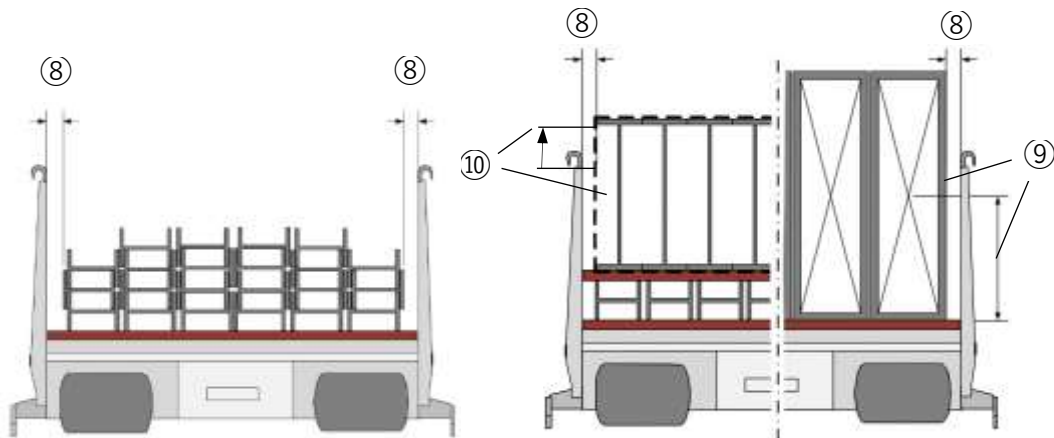

- ⑪ Sections and bundles loaded at a lateral distance to walls, sides or stanchions in excess of 10 cm, secured by
- ⑫(a) - lateral guide-pieces for single-layer loads of sections/bundles loaded directly on the floor; for multi-layer loads, these are only permitted on the top layer (this securing method is not suitable for stacked single sections), **or**
- ⑫(b) - indirect fastenings **or**
- ⑫(c) - bindings,
- one binding pulled tight per 6 m length, at least two per at least two bindings per length of sections/bundles outer bindings between 50 and 100 cm from the ends of the sections/bundles.
- ⑬
- If the width/height ratio is  $< \frac{5}{10}$  without the possibility bundles shall be bound together, secure against tipping by means of at least four bindings in the opposite direction (loop lashings) between 50 and 100 cm from the ends of the sections/bundles. The number of bindings required depends on the load configuration.
- ⑭ Without additional securing for dovetailed sections in bulk with similar dimensions resting on the flanges in a pyramid shape, the underlying part of sections with similar dimensions resting on the effective width of the wagon, distance  $< 10$  cm from the walls, sides or stanchions.
- ⑮ Sections in bulk secured according to ⑫(b) individual bundles loaded on the upper layer with the edge facing outwards should be additionally secured at each end of the section stacks by bindings approximately in the middle of the last third of the section stacks length.

<sup>1)</sup> The minimum breaking strength (straight pull) corresponds to double the permitted tensile force (LC); this concerns only synthetic straps, woven-fabric straps and load securing straps, as well as lashing steel wire ropes and lashing chains

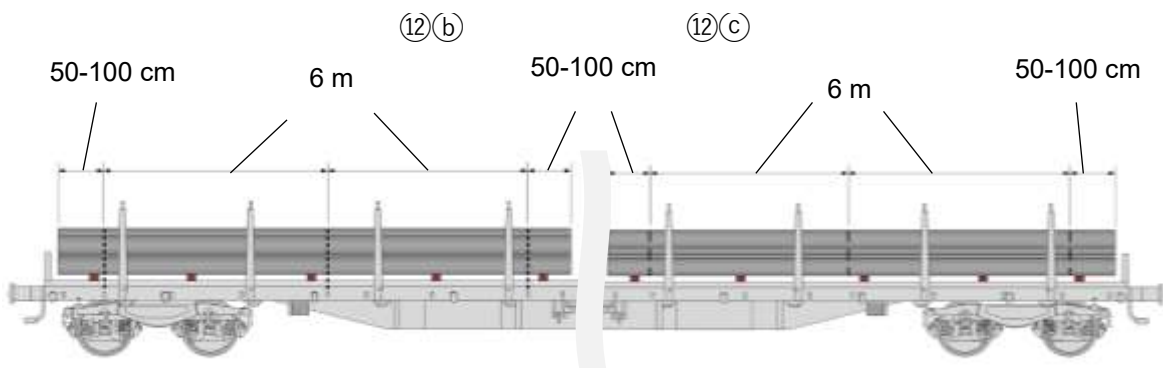
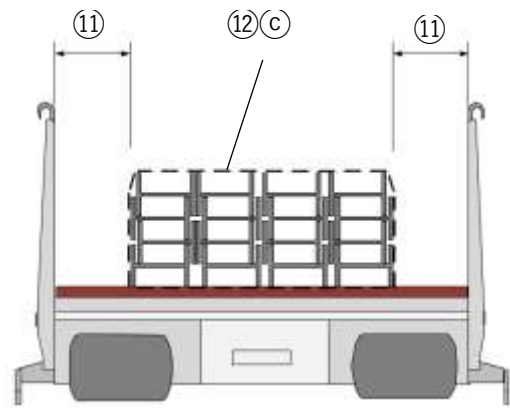
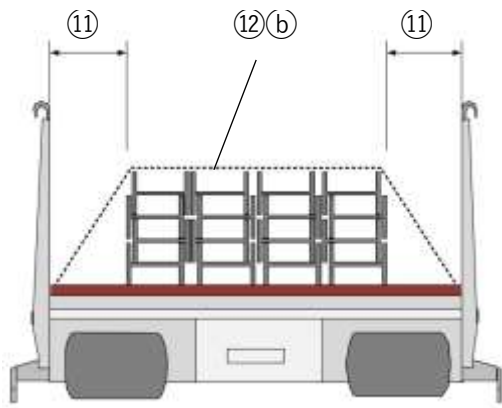
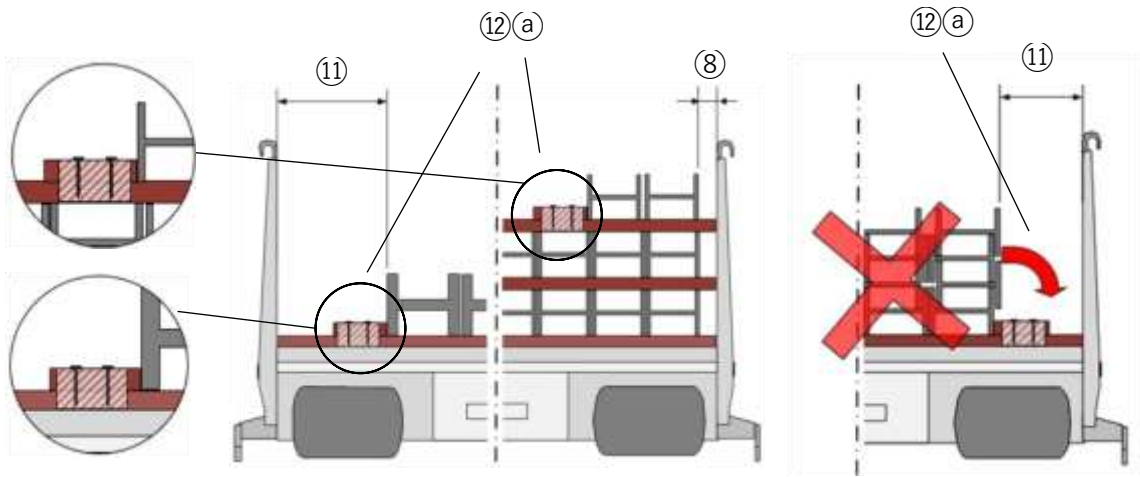

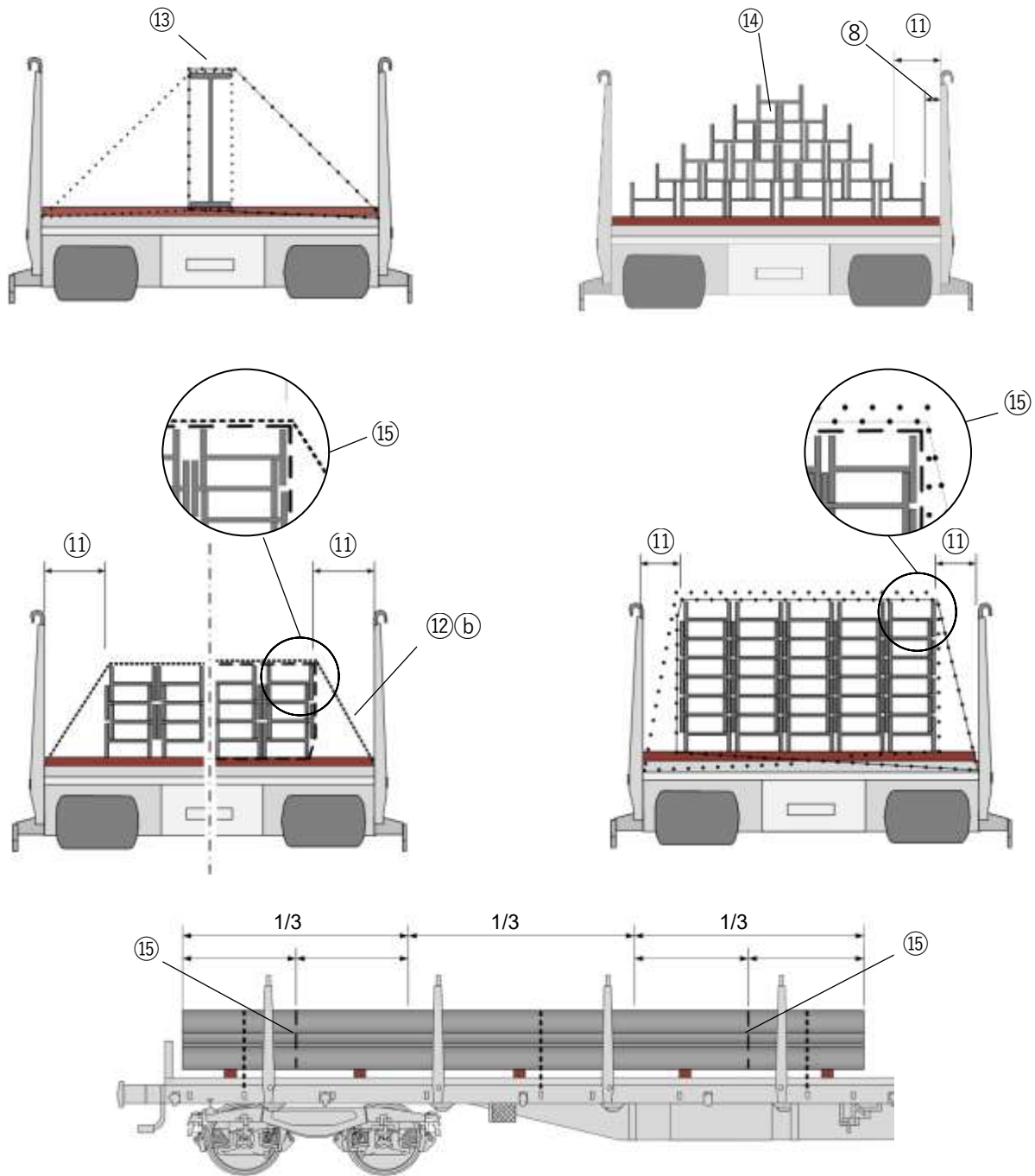

Intermediate loading gaps >10 cm between sections/bundles are to be filled with:

- ⑩(a) - guide-pieces nailed on floor/bolsters or on timbers/supporting scotches,
- ⑩(b) - at least two guide-pieces for the length of the sections/bundles, placed between 50 and 100 cm from the ends of the sections/bundles **or**
  - vertically inserted timbers secured in such a way as to ensure their effectiveness.
- Sections or bundles loaded with a width/height ratio <  $\frac{5}{10}$  should be secured against tipping by
  - ⑩(c)
    - side-by-side positioning **or**
    - insertion of vertical secured timbers to ensure their effectiveness.
  - and**
  - ⑩(d)
    - bound together **or**
    - ⑩(e)
      - with four bindings in opposite direction (loop lashings) according ⑬

Maximum permissible height difference between two side-by-side stacks 50%.

Bindings, guide-pieces and vertical timbers should be used twice on the longitudinal axis of the wagon approximately in the middle of the last third of the section/section stacks length.

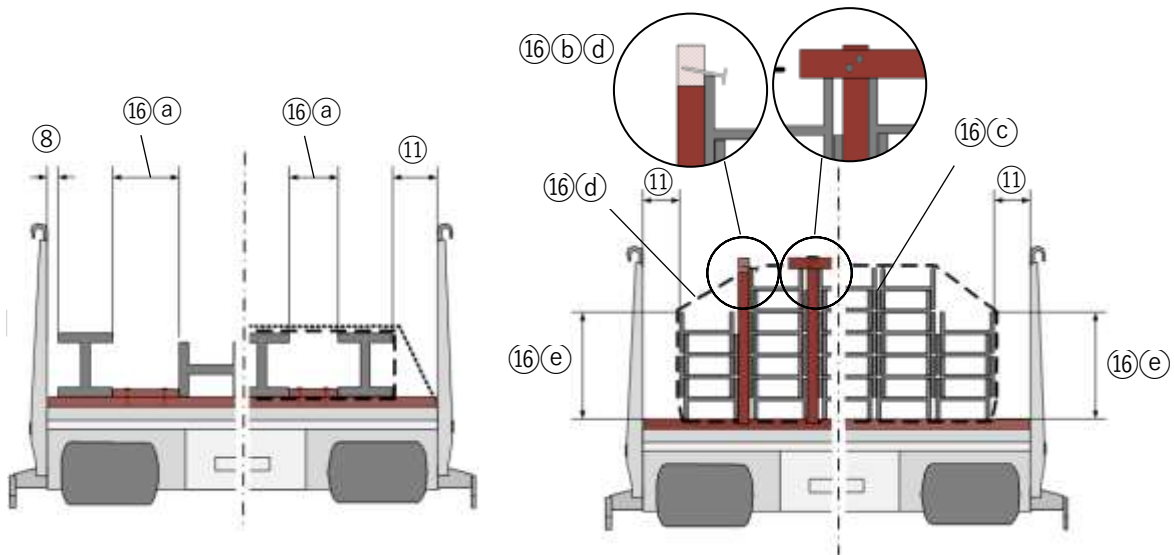

- ⑰(a) Effective height of walls, sides or stanchions: min. 10 cm
- ⑰(b) Sections and bundles not secured by the effective height should be bound together with the load sections below by at least one binding every 6 m, with at least two bindings per section/package, distance to the ends of the sections/bundles between 50 and 100 cm
- ⑰(c) If, however, securing is done according to ⑫(b), it should be secured with at least two additional bindings, whereby these end loop lashings should be placed in the middle of the last third of the section/bundle length. The number of required bindings depends on the load configuration.

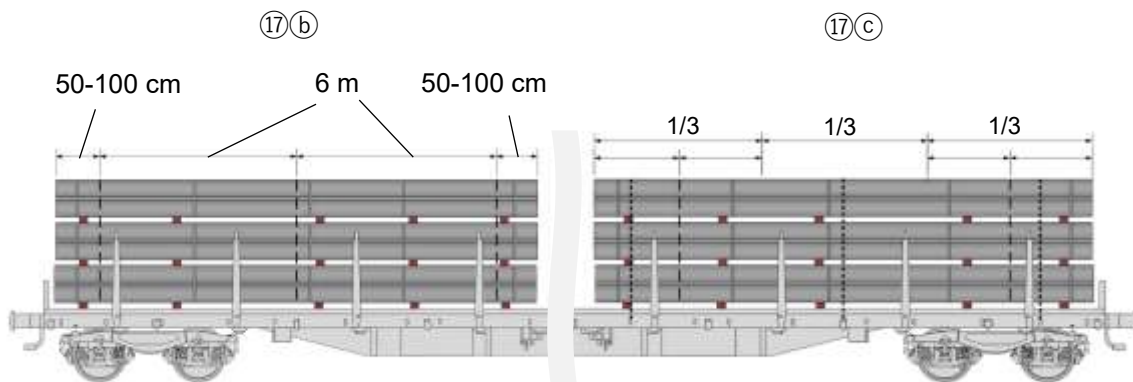
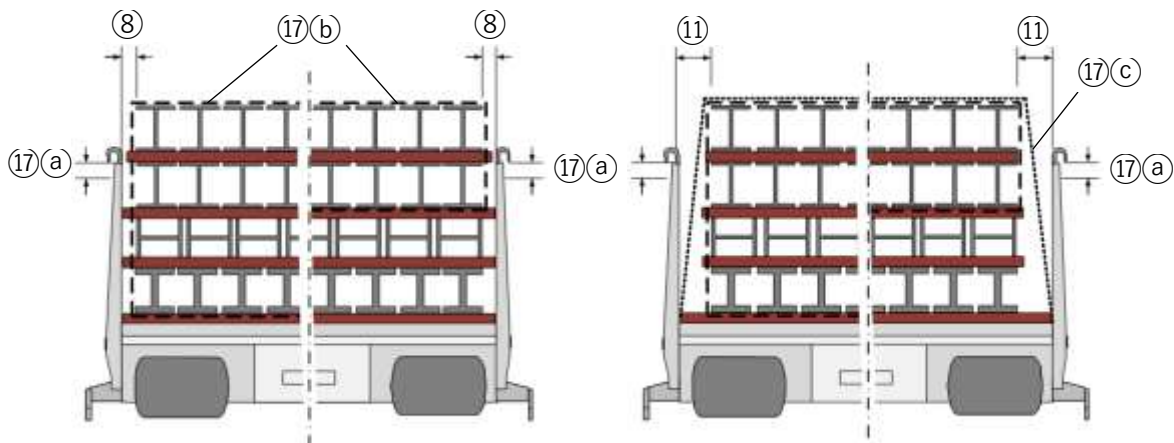

- ⑱ When held by two pairs of stanchions, sections and bundles should extend beyond the centre of the stanchions by at least

50 cm

30 cm

- ⑲ (a) If the sections/bundles are only secured by one pair of stanchions or for which overlapping distances are lower than 50 or 30 cm: secure loading

- ⑲ (b) - by wooden guide-pieces nailed on each side with 1 nail/1500kg load with at least two nails per guide-piece **and**, for stacked sections, by at least two bindings between 50 and 100 cm from the ends of the sections or
- ⑲ (c) - by fastening in opposite direction (loop lashings) placed between 50 and 100 cm from the ends of the sections/bundles to be secured.

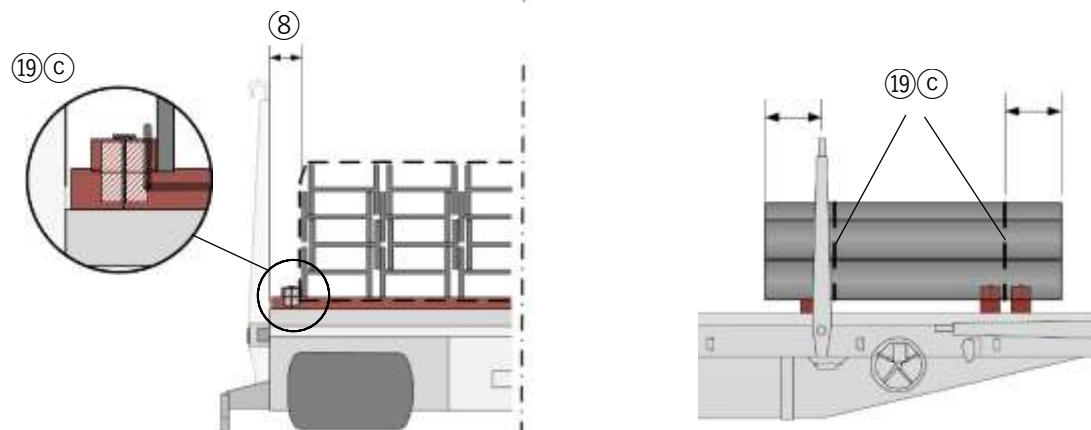
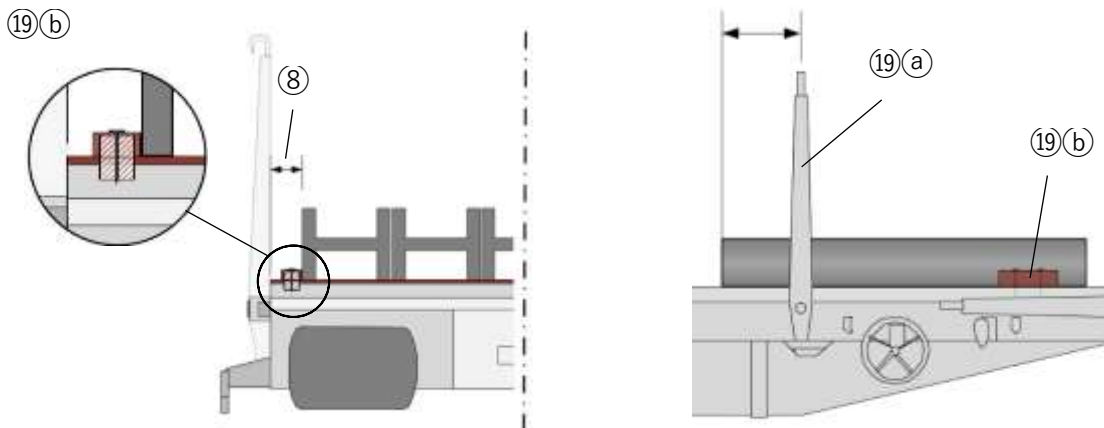
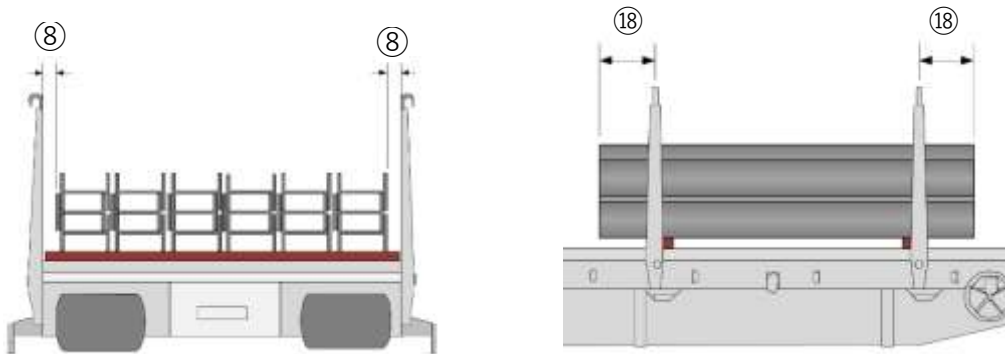



## 1.6.2 Sections (ungreased) loaded in staggered formation

Single wagons and groups of wagons

Wagons in block trains or combined transport  
Wagons with long-stroke shock absorbers

### Type of goods

Bundles of steel sections or girders with various cross-sections and approximately equal in length must be loaded in staggered formation in order to ensure optimum use of the wagon's loading capacity.

Binding of bundles: one binding per 3 m section or part thereof; at least two bindings between 30 and 100 cm from the ends of the bundles; breaking strength<sup>1)</sup> of bindings: min. 1400 daN.

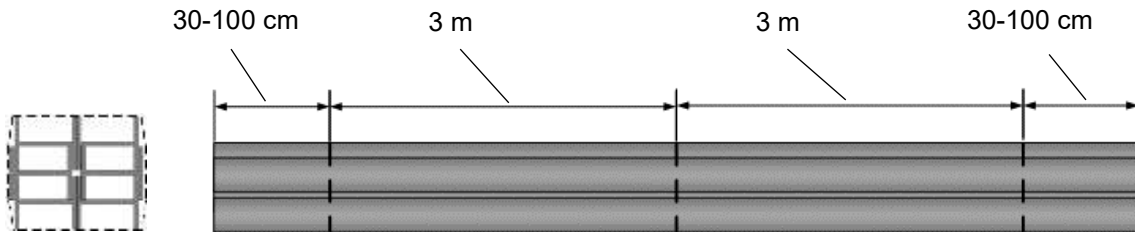

### Wagons

Wagons with walls, sides or stanchions and wooden floors or wooden bolsters.

### Method of loading

Sections and bundles are to be loaded directly onto the wagon floor, or on bolsters or wooden timbers:

- distributed, wherever possible, across the useable width of the wagon,
- ① ○ and loaded in staggered formation along the useable length of the wagon in order to ensure maximum use of the wagon's loading capacity. If loaded in staggered formation, the stacks must overlap for at least  $\frac{1}{3}$  of their length. If they overlap for more than  $\frac{2}{3}$  of their length, they are no longer considered to be loaded in staggered formation.

Bundles are to be stacked in one or more layers, or dovetailed sections.

- ② Crossways clearances over 10 cm are to be secured in accordance with ⑤ or are to be filled with wooden scotches nailed to inserts or vertical timbers, in which case they may be secured in accordance with ⑥.

In principle, all the dovetailed bundles or sections in a layer must be of similar height. Any differences in height must be fully compensated for by additional inserts (of rectangular cross-section resting on the broader face).

- ③ Supporting scotches and timbers shall be:
  - made of sound, untreated wood in accordance with EN 338, strength class at least C24,
  - made of a single piece, cut such that they present a sharp edge on all sides,
  - at least 6 cm thick, minimum cross-section depending on intended use,
  - of square or rectangular cross-section or rest on the broader face,
  - ③<sub>a</sub> ○ If supporting scotches or timbers in pairs are used, they should be secured against movement **or** a longitudinal distance of at least 1.5 m should be maintained between two supporting scotches/timbers in pairs.
- ④ Sections and bundles are to protrude beyond the supporting scotches and timbers by at least 50 cm.

<sup>1)</sup> Minimum breaking strength (straight pull) is equivalent to twice the permissible tensile strength (LC) and only applies to synthetic straps, woven straps and load-securing straps, as well as lashing steel wire ropes and lashing chains.

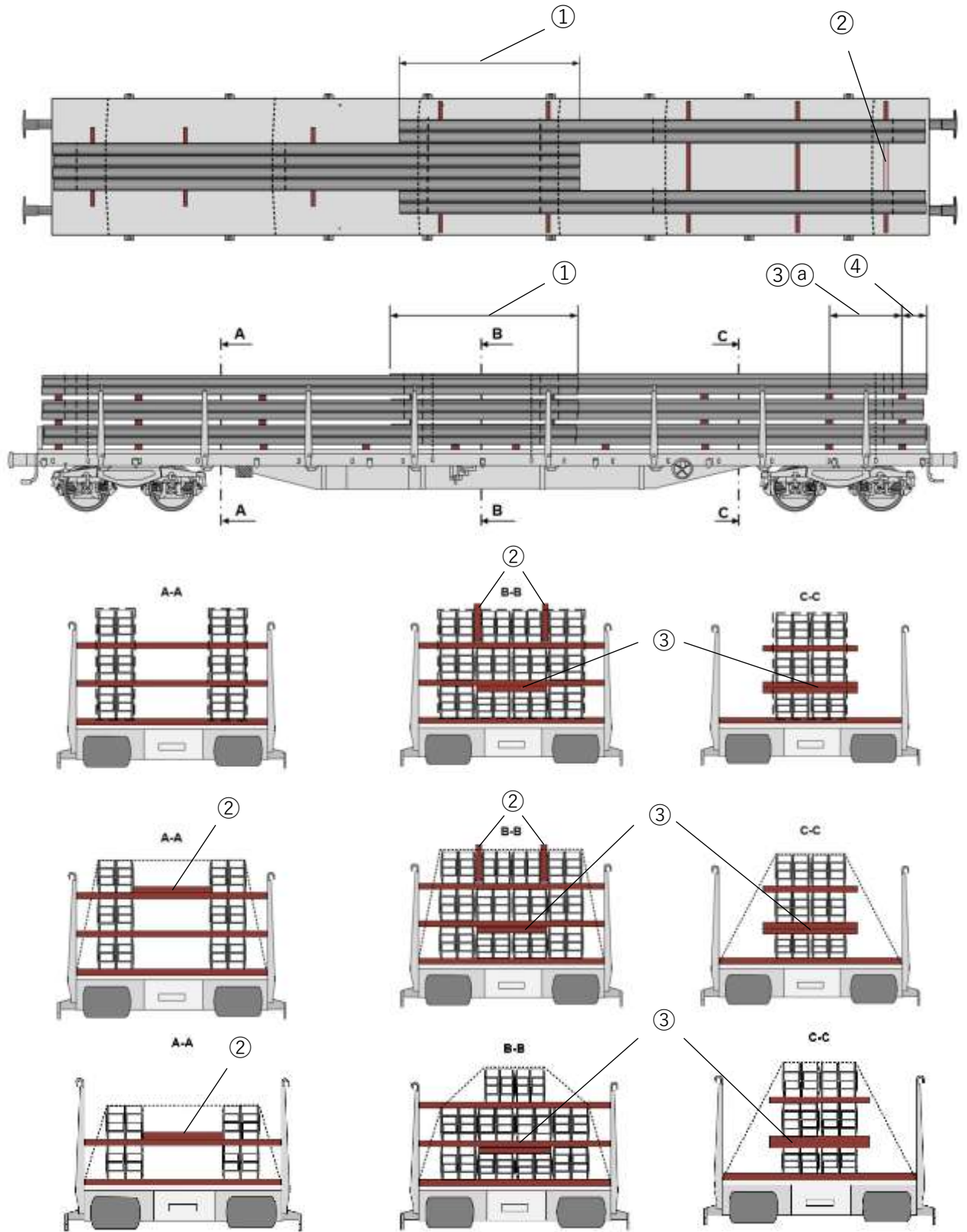



### Additional indications

Load of wagons: see information sheet 0.1,

Concentrated loads are to be calculated in accordance with UIC Loading Guidelines, volume 1, number 3.4.

Single-use bindings: see information sheet 0.6,

Indirect fastenings: see information sheet 0.7.

All bindings pulled tight and with edge protection.

Sizing, number and position of timbers and lateral scotches as well as the fastenings depends on the mass, length, characteristics, and vibration behaviour of the sections.

In accordance with the UIC Loading Guidelines, volume 1, number 5.5.3, it is possible to dispense with clearances from the front walls/sides when the goods are not vulnerable to impact.

The possibility of exceeding the full length of the wagon floor length marked on the wagon in accordance with information sheet 0.2 is only permitted during loading if a buffer wagon is used.

According to ③<sub>a</sub> and in accordance with the UIC Loading Guidelines, Volume 1, number 5.8.1, point ③, it is possible to avoid securing timbers/supporting scotches against lateral movement if parts of the load exert sufficient pressure on timbers/supporting scotches.

## 1.6.3 Steel bars and other sections in packages (ungreased)

Single wagons and groups of wagons

Wagons in block trains or combined transport  
Wagons with long-stroke shock absorbers

### Type of goods

- ① Steel bars and other sections which cannot roll bound into packages with rectangular or square cross-section, with one binding every 3 m and a minimum of two bindings
- ② Distance of bindings from the ends of packages: approx. 30 cm.  
Breaking strength<sup>1)</sup> of bindings: at least 1400 daN  
Synthetic and woven bindings with edge protection only.

### Wagons

Wagons with walls, sides or stanchions and wooden floor

### Method of loading

Packages should be loaded onto bolsters or wooden timbers

- ③ In one or more tiers, wherever possible across the full width of the wagon.
- ④ Timbers and supports, cut in such a way as to ensure that all the edges of the wood used are sharp, minimum dimensions in accordance with purpose of use:
  - timbers with rectangular cross-section resting on the broader face,
  - intermediate timbers also with square cross-section
    - o of one piece or a maximum of three overlapping pieces sufficiently bound and covering the full width of the load or load unit (see \*\* below).
- ⑤ Packages should extend at least 50 cm beyond the wooden timbers and intermediate timbers.
- ⑥ Minimum clearance to be left when loading

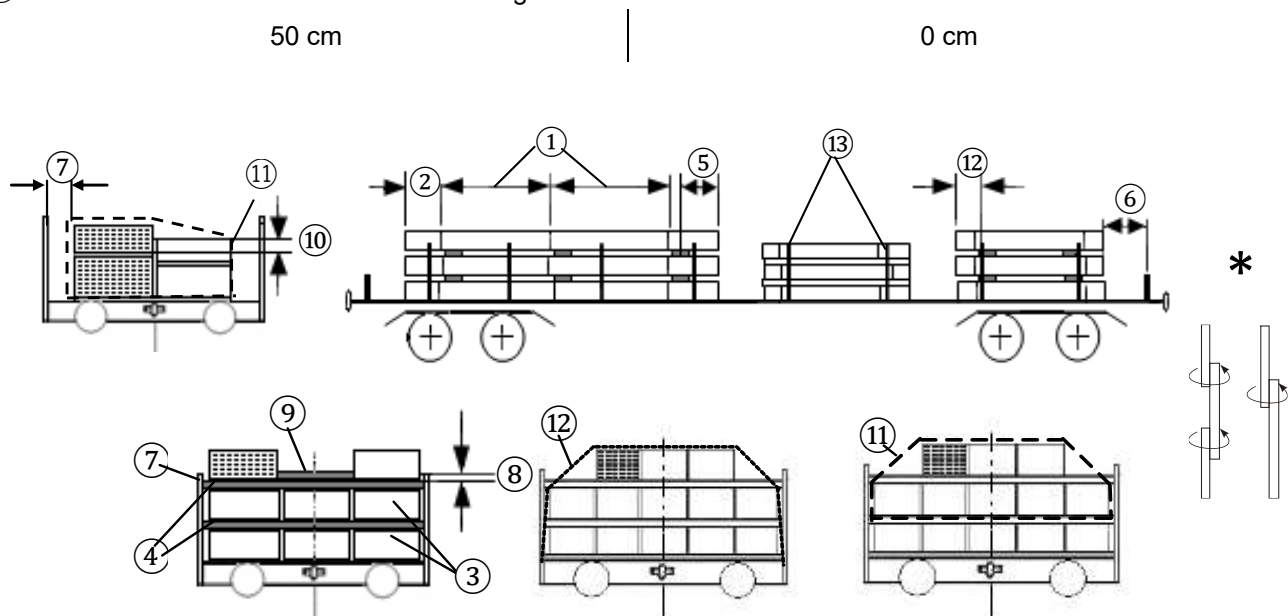

### Securing

- ⑦ Packages secured directly by the walls, sides or stanchions of the wagon (lateral distance  $\leq 10$  cm).
- ⑧ - effective height: min. 10 cm,
- ⑨ Intermediate space should be filled with pieces of wood (nailed in place)  
or where ⑨ is not possible secured in accordance with ⑪
- ⑩ Adjacent packages on the upper layer must have a minimum effective coverage of 3 cm.

<sup>1)</sup> Minimum breaking strength in tangent traction is equivalent to twice the permissible traction strength (LC) and only applies to synthetic straps, woven straps and load-securing straps, as well as lashing steel wire ropes and lashing chains.

### 1.6.3

In case of lateral distances to walls, sides or stanchions in excess of 10 cm where distances between packages in the upper layer may be a maximum of 8 cm:

- ⑪ - Packages shall be bound together (breaking strength 1400 daN) with one binding for every 3 m length and at least two bindings per stack, or
- ⑫ - secured by indirect fastenings<sup>2)</sup>: synthetic or woven straps with edge protection: breaking strength min. 2800 daN, one fastening for every 3 m length, at least two fastenings per stack.
- ⑬ Packages held by only two stanchions (on each side) should extend beyond the stanchions by at least

50 cm

30 cm

#### Additional information

Load of wagons: see information sheet 0.1,

Single-use bindings: see information sheet 0.6,

Indirect fastenings: see information sheet 0.7.

By virtue of point 5.5.3 of the UIC Loading Guidelines, volume 1, it is possible to dispense with clearances from the end walls/sides when the goods are not vulnerable to impact.

---

<sup>2)</sup> In case on non-compliance with information sheet 0.7, secure in accordance with ⑪.

## 1.6.4 Steel billets

Single wagons and groups of wagons

Wagons in block trains or combined transport  
Wagons with long-stroke shock absorbers

### Type of goods

Steel billets of various dimensions and surfaces

### Wagons

Wagons with walls, sides or stanchions and wooden floor

### Method of loading

Steel billets loaded directly onto the wagon floor, on bolsters or on wooden timbers

- ① - in tiers no higher than the top of the walls, sides or stanchions, if possible, spread over the full width of the wagon
  - only billets of the same height should be laid next to one another
  - use at least two timbers per length of billets
- ② Softwood timbers
  - of rectangular cross-section (resting on the broader face)
  - of one piece or a maximum of three overlapping pieces covering the full width of the load (approx. 4 cm thick)
- ③ The steel billets should extend beyond the timbers and bolsters by at least 50 cm
- ④ minimum clearances

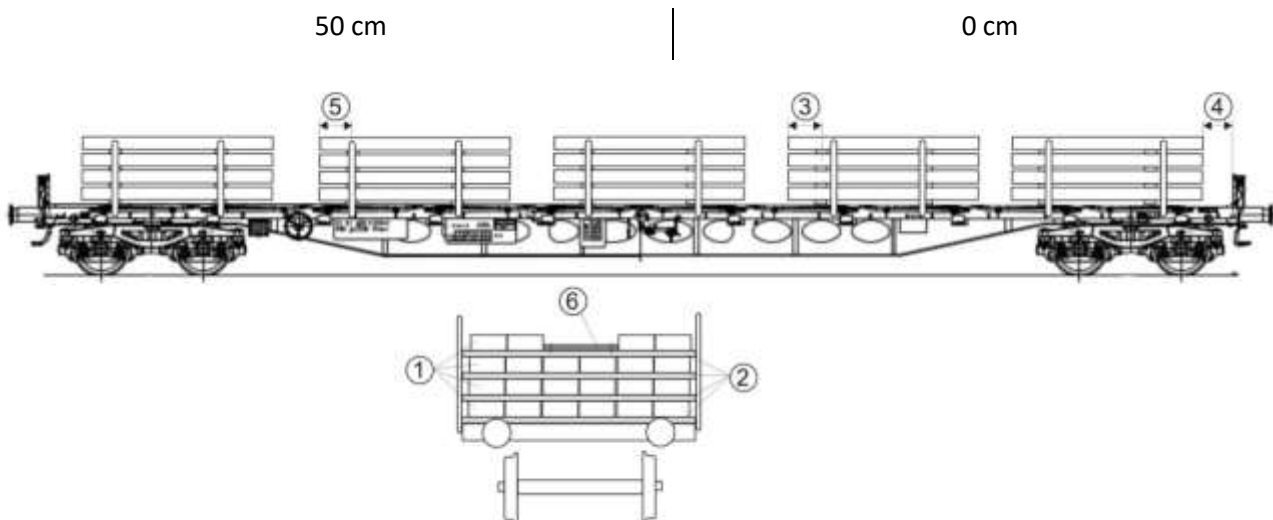

### Securing

The steel billets are secured directly by the walls, sides or stanchions

- ⑤ - when secured by only two stanchions on each side, the steel billets must extend beyond the centre of the stanchions by at least
  - 50 cm
  - 30 cm
- ⑥ - intermediate spaces should be filled with wooden timbers (nailed in place)

### Additional indication

Load of wagons: see information sheet 0.1



## 1.6.5 Steel rod for reinforced concrete (up to 36 m long)

Single wagons and groups of wagons

Wagons in block trains or combined transport  
Wagons with long-stroke shock absorbers

### Type of goods

Flexible steel rod for reinforced concrete, in bundles

### Wagons

Wagons with sides or stanchions and collapsible end boards

### Method of loading

① Bundles loaded in a maximum of four tiers (dovetailed), directly onto the wagon floor, on bolsters or on wooden timbers.

Clearances from:

- ② - sides and stanchions: approx. 10 cm;
- ③ - collapsed end boards: at least 5 cm vertical clearance (raised on wooden timbers).
- ④ Clearance: at least 50 cm.
- ⑤ Bundles should project beyond the wooden timbers by approx. 1 m.

Wooden timbers should be:

- ⑥ - of one piece across the full width of the wagon,
- nailed to wagon floor for wagons without sides.

Load per individual wagon:

- wagon with individual axles: maximum 75%,
- bogie wagon: maximum 85%,  
of the corresponding load limit.

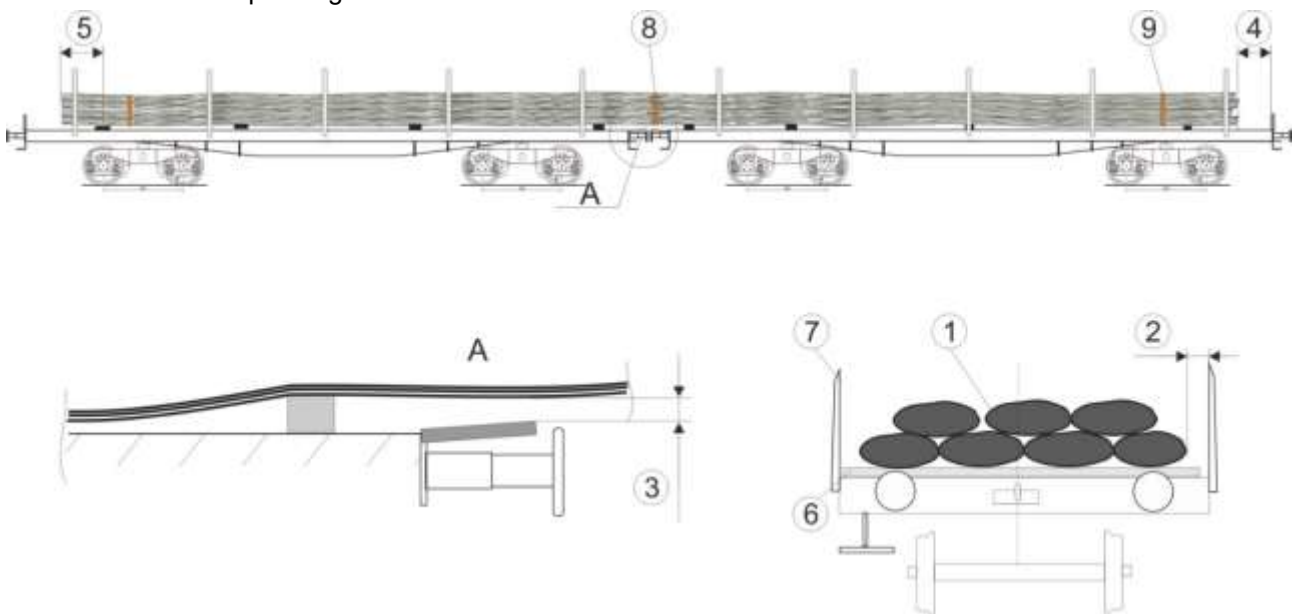

### Securing

- ⑦ Bundles should be secured by sides and stanchions,
  - with load bound using 8 mm diameter wire or a strap with 4000 daN breaking strength<sup>1)</sup>
- ⑧ • between wagons and
- ⑨ • approx. 1 m from the end, on wagons without sides.

### Additional indications

Load of wagons: see information sheet 0.1,  
Single-use bindings: see information sheet 0.6

<sup>1)</sup> Minimum breaking strength in tangent traction is equivalent to twice the permissible traction strength (LC) and only applies to synthetic straps, woven straps and load-securing straps, as well as lashing steel wire ropes and lashing chains.



## 1.6.6 Sheet piling sections (ungreased)

Single wagons and groups of wagons

Wagons in block trains or combined transport  
Wagons with long-stroke shock absorbers

### Type of goods

- ① U-shaped sections, stacked one on top of another, forming a loading unit due to stacking.
- ② Assembled U-sections, stacked one on top of another and resting on wooden supports on one side, form a loading unit due to stacking.
- ③ Assembled Z-sections, stacked one on top of another, forming a loading unit due to stacking. These loading units are not bound into units.

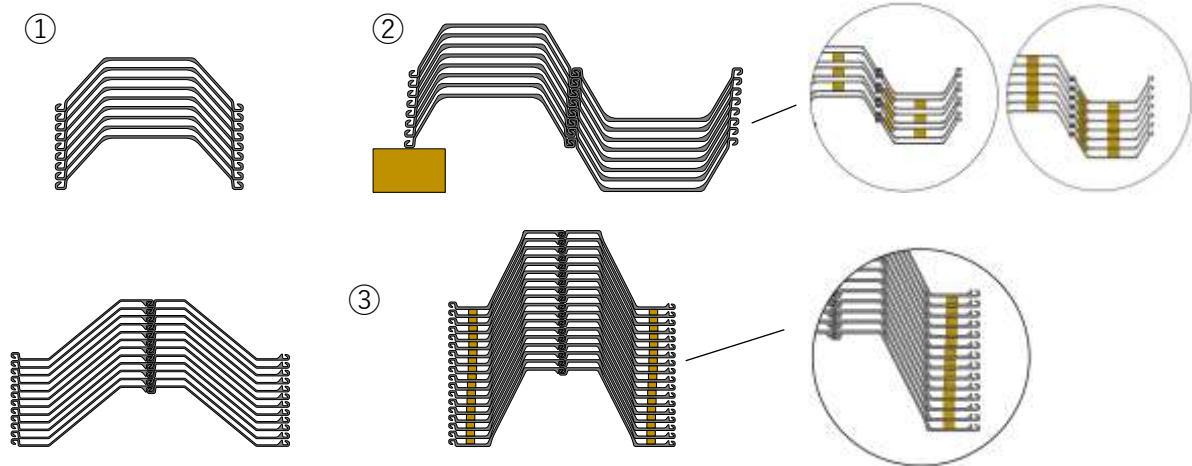

### Wagons

Wagons with wooden floor with fixed or retractable bolsters or steel floor with fixed wooden bolsters, stanchions, with or without side- or end-doors/-walls.

### Method of loading

Sheet piling sections should be loaded longitudinally onto the wagon floor, on wooden bolsters or supports, distributed, wherever possible, over the full length and the effective width of the wagon; the sections can be separated by timbers to facilitate loading/unloading. Good stability crossways must be ensured, if necessary, using stabilising timbers.

- ④ Sections are to protrude beyond the bolsters, timbers and supporting scotches by at least 50 cm.
- ⑤ The sliding distances at the ends of the wagon are not applied.
- ⑥ U-shaped sections, individual or stacked.
- ⑦ a Assembled U-sections, individual or stacked on top of another, resting on one side on the wagon floor, bolsters or supporting scotches and secured on one side only by wooden supporting scotches (support timbers) to ensure a horizontal position of the load unit.
- ⑦ b Support timbers of square or rectangular cross-section (approximately 25 cm long), cut sharp, and resting on the broader face, should be secured to their bases (floor, supporting scotches or bolsters) by penetrating dowels. The width of the support corresponds to the width of the base.
- ⑦ c If necessary, the base should be adapted to the support timbers by appropriate means.

## 1.6.6

They are affixed

- at least two per stack up to 8 m in length,
- for longer stacks, four evenly support timbers evenly distributed.

Three support timbers are permitted if the load unit, due to its length, can only rest on three fixed bolsters.

- ⑧ **Z-shaped sections stacked one on top of another, with the opening facing downwards.** Sections can be separated by timbers to facilitate loading/unloading.
- ⑨ **Maximum loading height: total height  $\leq 1.3 \times$  support width.**

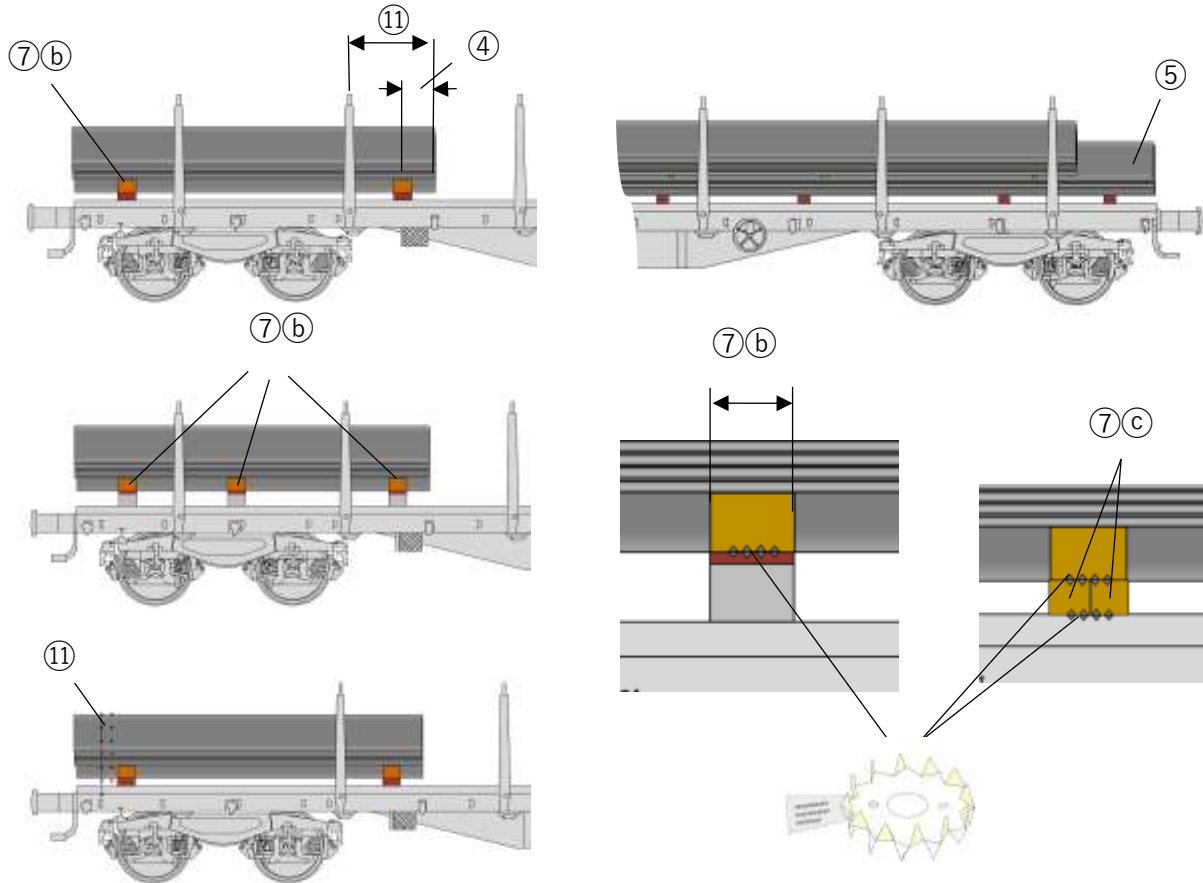

**Fastening in opposite direction (loop lashings)**

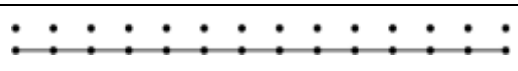

### Securing

- ⑩ Transversally, sections secured by the friction coefficient, by the walls, sides stanchions. The section edges in the upper position are secured by the effective height of the walls, sides or stanchions, min. 10 cm.  
Each end of load unit not secured by the effective height of 10 cm of the stanchions, should be bound together by one binding (minimum breaking strength<sup>1)</sup> of 1400 daN), distance to the ends of the sections between 50-100 cm, maximum distance between two bindings 6 m, with at least two bindings per load unit.

<sup>1)</sup> Minimum breaking strength in tangent traction is equivalent to twice the permissible traction strength (LC) and only applies to synthetic straps, woven straps and load-securing straps, as well as lashing steel wire ropes and lashing chains.

- ⑪ If short sections are only secured by two pairs of opposite stanchions, the sections should extend beyond the centre of the stanchions by at least 50 cm in the longitudinal direction of the wagon **or**

if the sections/bundles are only secured by one pair of stanchions or for which overlapping distances are lower than

50 cm

|

30 m

secure loading by fastening in opposite direction (loop lashings) placed between 50 and 100 cm from the ends of the sections/bundles to be secured.

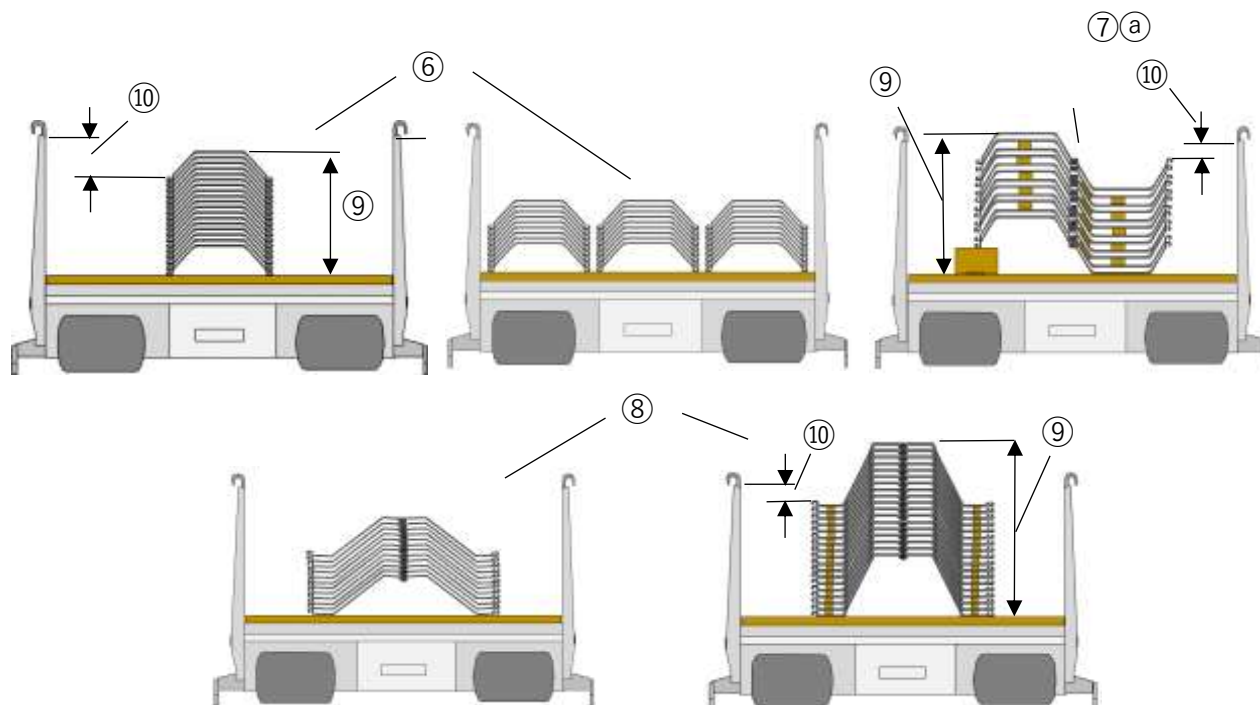

### Additional indications

Load of wagons: see information sheet 0.1,  
Single-use bindings: see information sheet 0.6.

Sizing, number and position of timbers and lateral scotches as well as the fastenings depends on the mass, length, characteristics, and vibration behaviour of the sections.

In accordance with the UIC Loading Guidelines, volume 1, number 5.5.3, it is possible to dispense with clearances from the front walls/sides when the goods are not vulnerable to impact.

Sizing, number and position of timbers and lateral scotches as well as the fastenings depends on the mass, length, characteristics, and vibration behaviour of the sections.

## 1.6.9 Steel slab

Single wagons and groups of wagons

Wagons in block trains or combined transport  
Wagons with long-stroke shock absorbers

### Type of goods

Continuous cast steel slab, rough-surfaced with rectangular cross-section

### Wagons

Wagons with walls, sides or stanchions and wooden floor

### Method of loading

It is to be ensured before loading that the wagon floor, bolsters and timbers and supports are free of ice, frost and snow.

- ① Slabs should be loaded directly onto the wagon floor (flat slabs, not curved), on bolsters or onto wooden timbers:
  - spread over as wide an area as possible
  - slabs of the same height next to one another, otherwise individual stacks with height less than width, widest slabs underneath
  - stacking in four tiers maximum
- ② - tiers separated by two timbers
- ③ - such that there is no contact between slabs

Timbers and supports should be:

- of wood (minimum thickness 3 cm), all sides cut sharp, of square cross-section or rectangular cross-section resting on the broader face, of one piece or a maximum of two pieces which are sufficiently bound together, over the full width of the load unit. In case of distances in excess of 10 cm from walls, stanchions or sides the supports shall extend beyond both sides of the load. Where wagons with integrated bolsters are used with separate timbers positioned on them the timbers must be sufficiently secured to the bolsters.
- ④ - A load consisting of a maximum of two stacks secured by walls/stanchions/sides shall be considered a unit.
  - ⑤ - arranged such that the slabs project beyond them by at least 50 cm.
  - ⑥ Minimum clearances

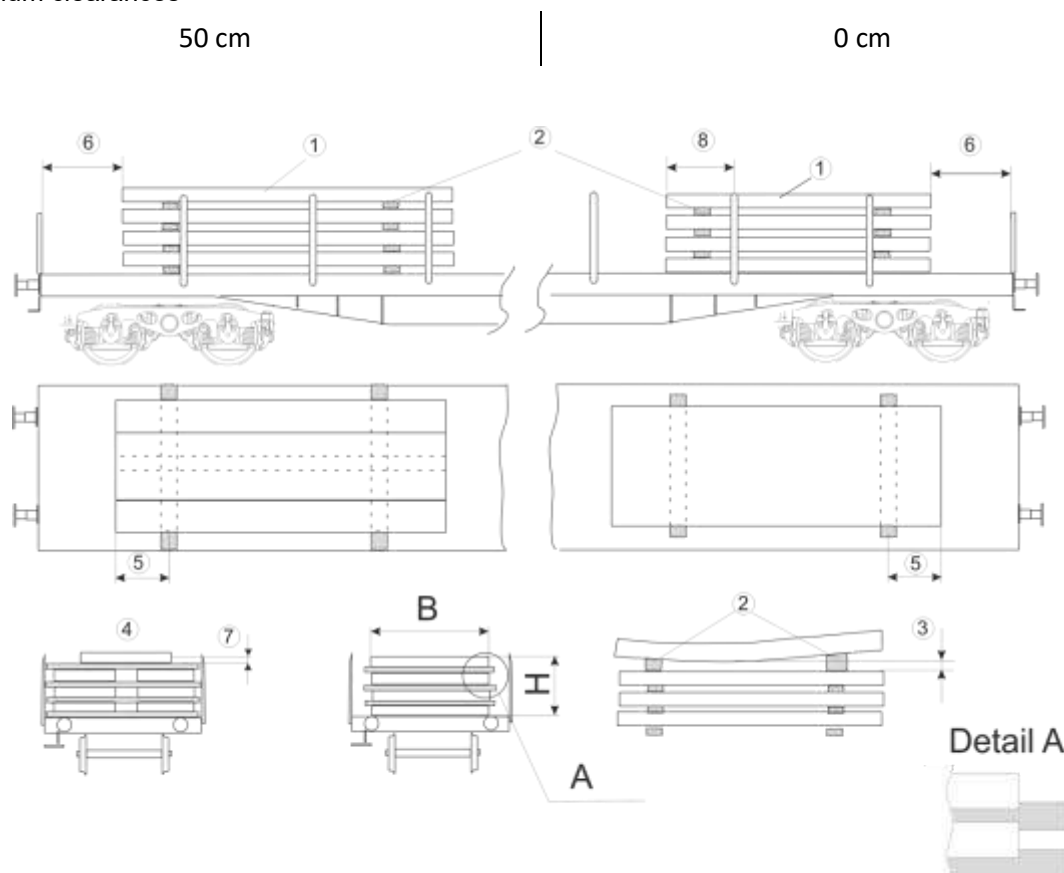

## 1.6.9

### Securing

By walls, sides or stanchions

For the first tier

- slabs loaded directly onto the wagon floor: secured by walls, sides or stanchions, irrespective of the distance between the load and the walls, sides or stanchions, due to the surface roughness of the slabs.
- Or by timbers or bolsters which project beyond the width of the load.

For upper tiers:

- in cases of lateral distances of more than 10 cm secured by intermediate timbers which project beyond the width of the load.

⑦ Effective height of the walls, sides or stanchions at least 10 cm.

⑧ When secured by only two stanchions, the slabs must extend beyond them by at least

50 cm



30 cm

### Additional indications

Load of wagons: see information sheet 0.1,

The temperature of the goods transported must not pose any risks.



## 1.7.1 Steel rods loaded onto wagons

Single wagons and groups of wagons

Wagons in block trains or combined transport  
Wagons with long-stroke shock absorbers

### Type of goods

Steel rods

- in bundles
- number of bindings according to diameter, length and weight of bundle:  
one fastening for every 3 m length, at least two fastenings per bundle, positioned at least 50 cm and at most 1 m from bundle ends.
- fastenings pulled tight.

### Wagons

Flat wagons with or without end walls or stanchions and with side walls or stanchions and with wooden floors or timbers.

### Method of loading

- ① Bundles loaded across the whole width of the wagon in a maximum of four tiers (dovetailed) directly onto the wagon floor, bolsters or timbers; loads shall be of rectangular cross-section, resting on the broader face.
  - ② Shortest bundles loaded lengthways, one behind the other or overlapping.
  - ③ On the upper layers bundles are dovetailed. To facilitate transhipment, they may be separated using scotches placed at an angle or vertically.
- For loadings without side walls or above side walls:
- ④ - in case of timbers situated more than 1 m from bundle ends uncontrolled swinging of said ends must be prevented.
  - ⑤ - bundle ends therefore rest on the wagon floor or additional timbers are inserted at the bundle ends. The timbers are secured against lateral displacement, e.g. with a minimum of four nails ( $\varnothing$  5 mm, depth of penetration at least 40 mm) **or**
  - ⑥ - indirect fastenings with integrated tensioning devices over the timbers (breaking strength<sup>1</sup>) of fastenings in tangent traction at least 2800 daN).

Clearances are not necessary

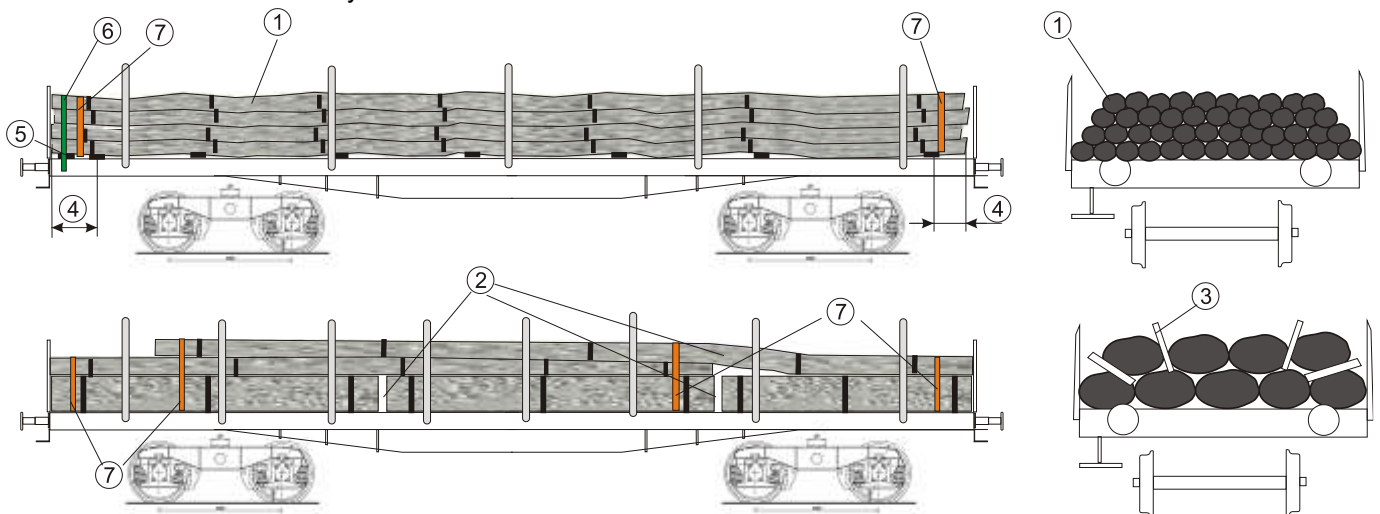

<sup>1</sup>) Minimum breaking strength in tangent traction is equivalent to twice the permissible traction strength (LC) and only applies to synthetic straps, woven straps and load-securing straps, as well as lashing steel wire ropes and lashing chains.

### 1.7.1

#### Securing

Bundles supported from the side by side walls or stanchions (including where lateral distances to stanchions are in excess of 10 cm, given the surface characteristics of steel rods)

Effective height of sides of stanchions at least 10 cm.

When secured by only two stanchions, bundles must extend beyond the stanchions by at least

50 cm



30 cm

- ⑦ Where bundle ends extend beyond stanchions by more than 1 m loads shall be bound together by means of double twisted wire ( $\varnothing$  5 mm) or a fastening (breaking strength at least 2800 daN).

#### Additional indications

Load of wagons: see information sheet 0.1,

Maximum dimensions of loads: see information sheet 0.2

Single-use bindings: see information sheet 0.6,

Indirect fastenings: see information sheet 0.7.

## 1.8.1 Rails loaded on one wagon

Single wagons and groups of wagons

Wagons in block trains or combined transport  
Wagons with long-stroke shock absorbers

### Type of goods

Rails of different dimensions and types

### Wagons

Wagons with walls, collapsible boards or stanchions, and

- wooden floor or
- wooden/lined with wood bolsters

### Method of loading

Rails loaded directly on the floor of the wagon, on cross-pieces or supporting scotches.

The number of inserts/supporting scotches shall be chosen in such a way that the stability of the stacks is ensured:

- ① - on one or several layers, if possible, over the entire width of the floor,
- ② - at most up to the top of the wall, collapsible board or stanchion.
- ③ Timbers and supporting scotches:
  - with a rectangular cross-section, resting on the broader face,
  - in a single piece resting on the entire width of the stack (thickness: 4 cm).
- ④ The rails shall project beyond the supporting scotches and inserts by at least 50 cm.
- ⑤ Clearance from the wagon ends

50 cm

0 cm

- ⑥ - If it is impossible to comply with point ⑤ (loading length fully used), compliance with the clearance requirements may be dispensed with, in accordance with the UIC Loading Guidelines, volume 1, number 5.5.3.
  - Where applicable, a buffer wagon is necessary.

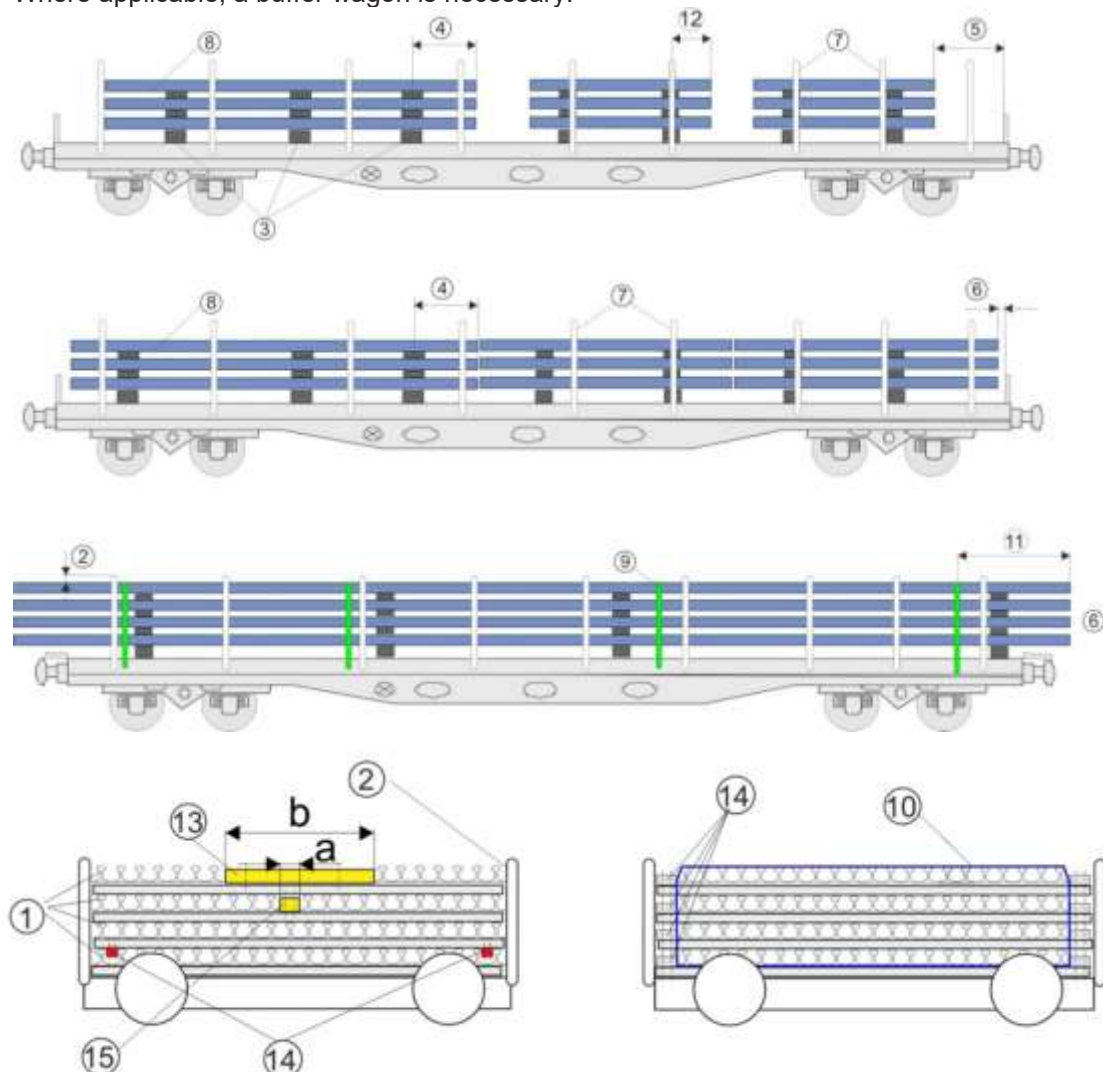

## 1.8.1

### Securing

Rails:

- ⑦ - secured directly by walls, sides or stanchions,
- in case of gaps greater than 10 cm or an overhang, by means of:
  - ⑧ • timbers attached to the supporting scotches/inserts by at least two nails ( $\varnothing$  approx. 5 mm) and
  - ⑨ • one indirect fastening, breaking strength<sup>1)</sup> at least 2800 daN (straight pull), per 6 m stack section or part thereof (at least two per stack), or
  - ⑩ • one binding per stack section of 6 m in length (at least two per stack), breaking strength of the bindings (straight pull) at least 1400 daN.
  - ⑪ • Distance between fastenings/bindings and stack ends: at least 30 cm.
- ⑫ In case of securing using only two stanchions, the rails shall project beyond the stanchion axis by at least:  

50 cm		30 cm
-------	--	-------

- ⑬ Gaps shall be filled by means of timbers (nailed).

Supporting scotches and other inserts must be secured against lateral movement, e.g.:

- supporting scotches nailed to the wagon floor,
- ⑭ - inserts consisting of wooden blocks nailed on the side, or
- ⑮ - wooden blocks nailed at the middle of the load ( $a \leq b$ ).

### Additional indications

Load of wagons: see information sheet 0.1,

Maximum dimensions of loads: see information sheet 0.2

Single-use bindings: see information sheet 0.6,

Indirect fastenings: see information sheet 0.7.

---

<sup>1)</sup> The minimum breaking strength (straight pull) corresponds to double the permitted tensile force (LC); this concerns only synthetic straps, woven straps and load securing straps, as well as lashing steel wire ropes and lashing chains.

## 1.8.2 Rails loaded on two wagons

Single wagons and groups of wagons

Wagons in block trains or combined transport  
Wagons with long-stroke shock absorbers

### Type of goods

Rails of the same geometrical cross-section and approximately equal length loaded on two wagons.

### Wagons

Bogie wagons with stanchions and wooden floors (R..., S...) and loading surfaces of the same height.

Each wagon should have two steel frames secured to the wagon body or stanchions.

Screw couplings should be tightened such that the buffers compress slightly.

### Method of loading

- ① The rails are to be laid in three layers, or up to four tiers depending on the wagon's load capacity (rails longer than 36 m to be laid in three tiers only) and design of the frame. They are to be placed upright, side by side, on supporting scotches positioned in the frames, and on wooden inserts. The rails are to be distributed evenly crossways in the wagon. Any incomplete tiers may only be placed in the topmost layer.

The stanchions positioned in front of the first frame and after the last are to be folded down.

Clearance from:

- ② - stanchions: approx. 15 to 40 cm (depending on frame design),
- ③ - collapsible end boards (folded) and vis-à-vis wagon floor (vertical distance): 5 cm min.,
- ④ - collapsible end boards of end wagons: 50 cm min.

The ends of the rails project:

- ⑤ - beyond the frames and supporting scotches by 1.5 to 3 m.
  - Where there is an overhang of less than 2 m, the outer inserts are not necessary.
- ⑥ The supporting scotches and inserts should be made of sound timber (compliant with EN 338, minimum strength class C24):
  - Made of a single piece and covering the entire width of the load.
  - Minimum cross-section: 18 x 15 cm for supporting scotches and approx. 12 x 8 cm for inserts.
  - At least two supporting scotches per wagon. In case of rails measuring at least 31 m in length, a third supporting scotch must be placed halfway between the two other supporting scotches, bearing in mind the need to adopt appropriate measures to reduce the friction coefficient of the sliding surfaces of this additional insert.
  - The supporting scotches should be integrated into the frames secured to the stanchions or wagon body. The frames should be fixed to the wagon floor with steel angles.
  - Number of inserts: two or three per tier per wagon (position: see drawing). When three supporting scotches are in use, the additional inserts must be positioned directly above the additional supporting scotch.
  - Inserts:
    - ⑦ • with wooden end-pieces or steel angles, bolted only from above and secured by a threaded rod, Fixing by through bolt, locked with a nut underneath
    - positioned at a distance of 0.8 to 1.2 m from the adjacent frames.
  - Measures reducing the coefficient of friction on the sliding surfaces of supporting scotches integrated into frames are not authorised.
- ⑧ - The width of the surface on which the inserts rest and the distance between the arms of the frames shall be approx. 8 to 16 cm greater than the complete width of the tier of rails (4 to 8 cm per longitudinal side of the wagon).
- ⑨ - The heads of the frames are to be linked by a chain (LC 1000 daN with pre-tensioning device) or by a synthetic strap (LC 1500 daN with anti-slackening device) (required pre-tensile force: approx. 300 daN). This binding is not necessary if it can be shown that the frames will withstand a load of up to 5000 daN at a height of 50 cm above the wagon floor.

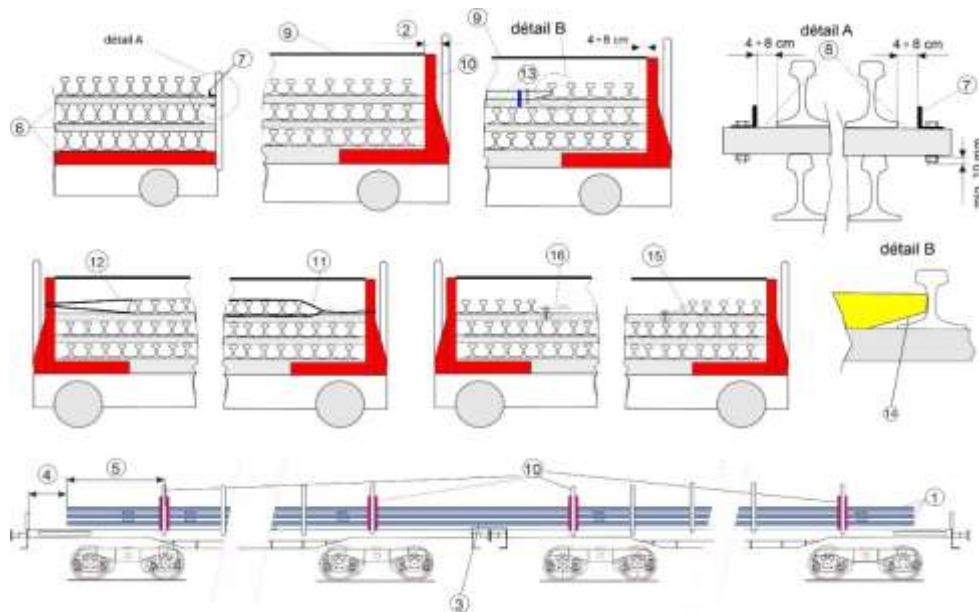

Frame positioned on wagon



View from above

### Securing

The rails are to be secured at the sides:

- ⑩ - by four steel frames secured to the stanchions or the wagon body and attached to the wagon floor by four steel angles (height helical-shank nails measuring 6x60 mm per angle). Other equivalent measures are authorised, such as frames with spikes on their bearing surface,
- of which two of the frames are positioned at each end of the load **and**
  - two further frames are positioned in the centre of the load (coupling area) to the right of the bogie centres.

- Frames may be made of steel sections measuring  160 mm or  180 mm.

Incomplete upper tiers are to be:  
secured in a central position

- ⑪ - using double-strand metal wire bindings (diameter 5 mm min.), **or**  
⑫ - bound together using straps tensioned in opposing directions (minimum breaking strength<sup>1)</sup>:  
4000 daN)

Any intermediary spaces along the wagon's lengthways axis are to be filled by means of:

- ⑬ - bevelled timbers (may not touch the rail base ⑭) screwed, attached or nailed to supporting scotches or inserts, **or**  
- steel angles ⑮ or wooden scotches ⑯ of sound timber (compliant with EN 338, minimum strength class C24) in the area around each frame.

### Additional indications

Hump and fly-shunting prohibited for these consignments.

Load of wagons: see information sheet 0.1,

The wagons are loaded up to 85 % of the load limit of the wagon and the line on which they are to run (category of line).

The maximum load on each wheelset (see volume 1 number 3.3.) must not be exceeded.

Single use bindings<sup>1)</sup>: see information sheet 0.6

<sup>1)</sup> Minimum breaking strength in tangent traction is equivalent to twice the permissible traction strength (LC) and only applies to synthetic straps, woven straps and load-securing straps, as well as lashing steel wire ropes and lashing chains.

## 1.8.3 Rails loaded on more than two wagons, up to 150 m in length

Single wagons and groups of wagons

Wagons in block trains or combined transport  
Wagons with long-stroke shock absorbers

### Type of goods

Rails loaded on more than two wagons, up to 150 m in length.

### Wagons

Flat wagons with bogies and wooden floors (R..., S...). Loading surfaces mostly at the same level.

### Method of loading

Rails should be laid in a maximum of three layers

- ① - supported with a crib in the middle of the central wagon **or**, in case of an even number of wagons, where possible, in the middle of one of the two central wagons.

On each wagon, load the rails:

- ② - on two frames positioned above bogie centres if possible; for end wagons on one frame if max.  $\frac{3}{4}$  of the floor space is used and
- on one timber (softwood possible).
- ③ - To help cope with vibrations, it is possible to insert a third ③ (softwood) supporting scotch and inserts at an appropriate location, in accordance with point ⑫. In this case, the timber must be secured to the wagon floor close to the stanchions, and the inserts must be positioned lengthways between the stanchions.
- After loading, the rails must rest on the middle insert. This insert may not be higher than the end inserts.
  - For the wagon with the crib the frames may be replaced by two inserts<sup>1)</sup> (softwood possible)

Cross-section of timbers: upwards of approx. 18 cm x 15 cm:

- ④ - the rails should project beyond the end frames by approx. 1.5 to 3 m.

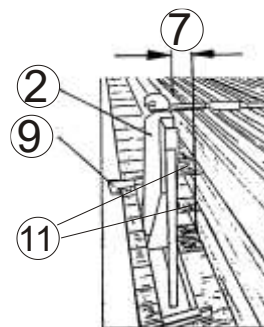
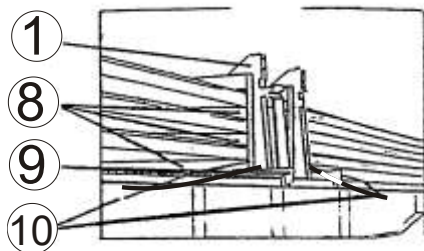

Clearance to:

- ⑤ - collapsed end-walls: approx. 5 cm vertical distance,  
⑥ - raised end-walls of the end wagons

Length of units	Minimum clearance
> 36 m to 60 m	75 cm
> 60 m to 90 m	100 cm
> 90 m to 120 m	125 cm
> 120 m to 180 m	150 cm

- ⑦ - frame uprights: approx. 10 cm.

<sup>1)</sup> Measures reducing the coefficient of friction on the sliding surfaces of these timbers are not authorised

### 1.8.3

Crib and frames made from welded steel U-sections:

- ⑧ - with steel spikes sticking into the wagon floor.
- ⑨ - serving as stops/guides for timbers and inserts.
- ⑩ - adapted to the loading width using adjustable stops.

The crib should be lashed down in each direction using double bindings (breaking strength<sup>2)</sup> of bindings straight pull: min. 10000 daN).

Bindings must be tensioned during loading such as to leave play of 10 to 30 mm.

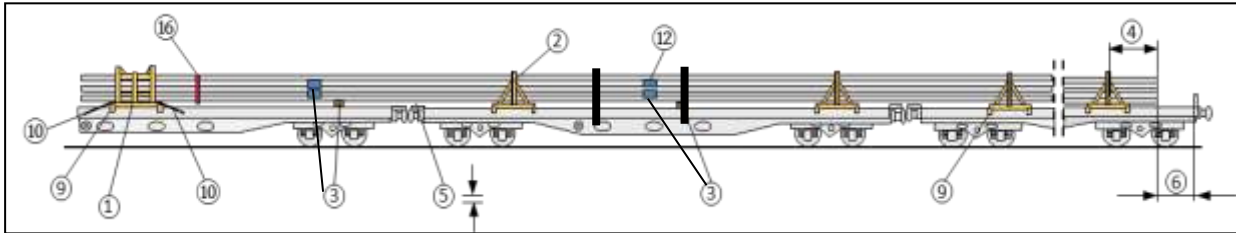

Scotches should be made of hard wood:

- ⑪ - of one piece, across the full load width and resting on the broader face,
- cross-section approx. 8 cm x 14 cm depending on configuration of metal-profile frames (see ⑫).

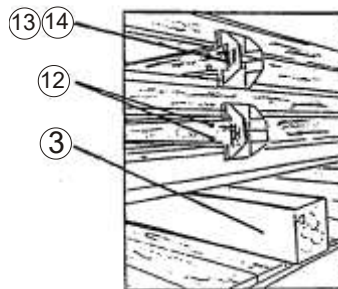

Using appropriate means, the coefficient of friction must be reduced on sliding surfaces (e.g. using appropriate lubricants, synthetic materials), except where clamped to the crib.

Intermediate timbers placed outside the crib and supporting frame should be:

- ⑬ - made of metal profile with hardwood timbers screwed in place or synthetic materials (  ),
- ⑭ - equipped at the ends with steel stops or other sufficiently strong material,
  - distance from base of rails: at least 4 cm,
  - facing upwards and downwards (stop height: at least 4 cm).

### Securing

- ⑮ - by double screw connection on the crib (comply with tightening torque) and
- ⑯ - by binding together left and right of the crib (approx. 1 m distance from the crib).
  - Binding with:
    - a breaking strength<sup>2)</sup> straight pull of min. 5000 daN,
    - edge protection on sharp edges with respect to the base of the rail.
- ⑰ laterally secured by the frames; during conveyance the frame fittings may not come into contact with the load

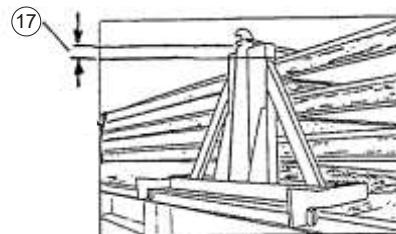
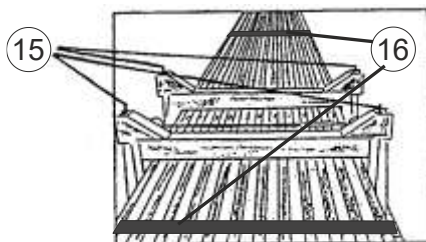

<sup>2)</sup> Minimum breaking strength in tangent traction is equivalent to twice the permissible traction strength (LC) and only applies to synthetic straps, woven straps and load-securing straps, as well as lashing steel wire ropes and lashing chains.

- ⑱ - If the upper layer is incomplete, the empty load spaces (crib and bearer frame) are to be filled with timbers. In the frames, the timbers are to be secured against displacement. To stabilise the load, a binding with ratchet lashing straps may be attached at both ends of the load (breaking strength straight pull of min. 5000 daN) ①. The binding must be moderately tensioned only ②. If bound together outside the range of the frames at the ends of the load ②, the frames must be secured by means of a suitable fastening ③ against falling over **or**
- ⑲ - in the zone of the frames bound together using straps with scuff protection tensioned in opposing directions (breaking strength<sup>2)</sup> 5000 daN minimum). The binding must be moderately tensioned only ② **or**
- ⑳ - in the zone of the frames with twisted wire loops with at least two wires (∅ 5 mm)

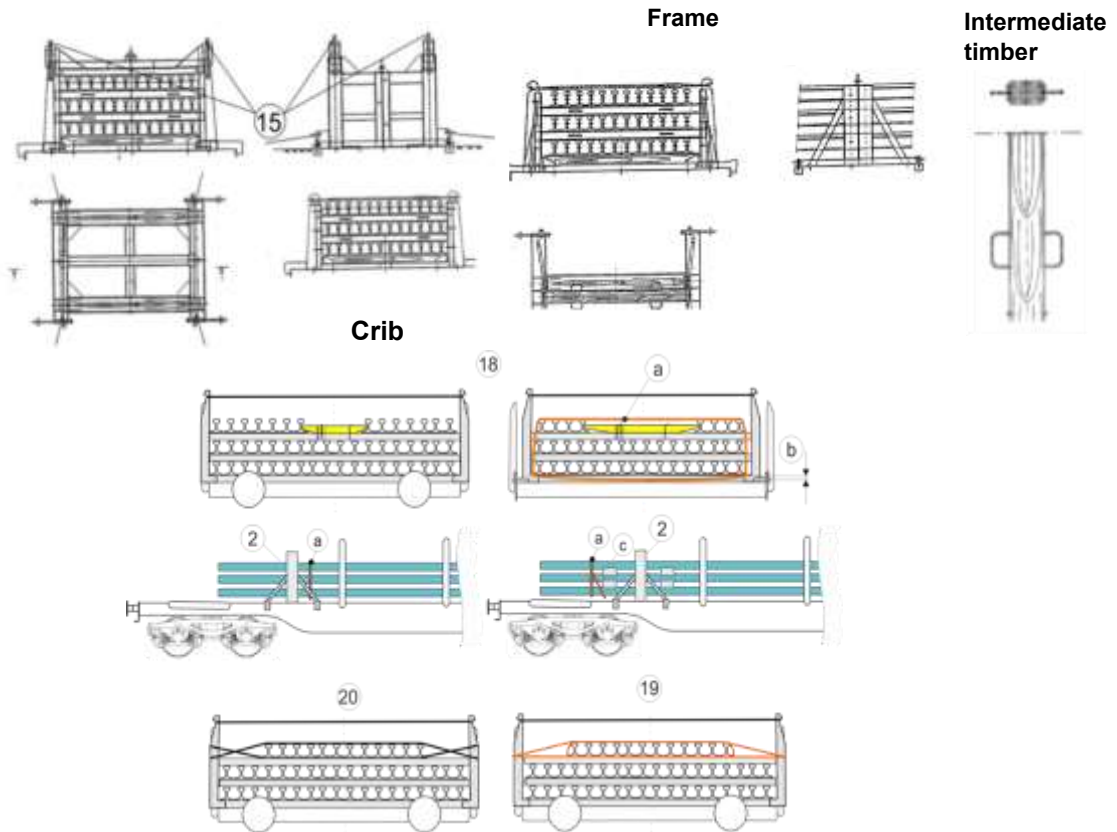

**Additional indications**

The wagons are loaded up to 85 % of the load limit of the wagon and the line on which they are to run (category of line).

The maximum load on each wheelset (see volume 1 number 3.3.) must not be exceeded.

Exceptional load on CFR, NRIC, Network Rail, GySEV, RFI, HŽ-Infrastruktura, SŽ-Infrastruktura, IŽS, ÖBB-Infrastruktur, PKP PLK, ADIF, TRAFIKVERKET, Infrabel, SNCF Réseau and TCDD; normal load in block trains for other members.

## 1.8.4 Rails loaded on two wagons, with spacers

Single wagons and groups of wagons

Wagons in block trains or combined transport  
Wagons with long-stroke shock absorbers

### Type of goods

Rails with the same profile, loaded on two wagons.

### Wagons

Bogie wagons with stanchions and wooden floors (R... S...) and loading surfaces of the same height.  
Screw couplings should be tightened such that the buffers compress slightly.

### Method of loading

- ① The rails are to be laid in three layers or up to four tiers, depending on the wagon's load capacity. They are to be placed upright, side by side, on supporting scotches or bolsters.
- The rails are to be distributed evenly crossways in the wagon. Any incomplete tiers may only be placed in the topmost layer.

The wagons are to be loaded up to 85% of the load limit of the line on which they are to run, bearing in mind that the load on the central bogies is to be calculated taking into account the calculations given in volume 1, number 3.3 as regards the maximum load on each wheelset based on the reference load limit for the line.

Clearance from:

- ② - stanchions: approx. 10 cm, max. 15 cm  
③ - collapsible end boards (folded) and wagon floor (vertical distance): 5 cm min.  
④ - collapsible end boards of end wagons: 50 cm min<sup>1)</sup>.

The ends of the rails project:

- ⑤ - 1 to 3 m beyond the inserts and supporting scotches.  
⑥ - 1 to 3 m beyond the stanchions equipped with spacers (those stanchions positioned beyond those with spacers must be folded away)

Supporting scotches and inserts should be made of sound timber (compliant with EN 338, minimum strength class C24).

- ⑦ - Made of a single piece and covering the entire width of the load.
- Rectangular cross-section min. 15x18 cm for supporting scotches, approx. 8x12 cm for inserts resting on the broader side.
  - Number of supporting scotches / bolsters: two per wagon. In case of rails measuring at least 31 m in length, a third supporting scotch/bolster must be placed halfway between the other two, bearing in mind the need to adopt appropriate measures to reduce the friction coefficient of the sliding surfaces of this additional insert.

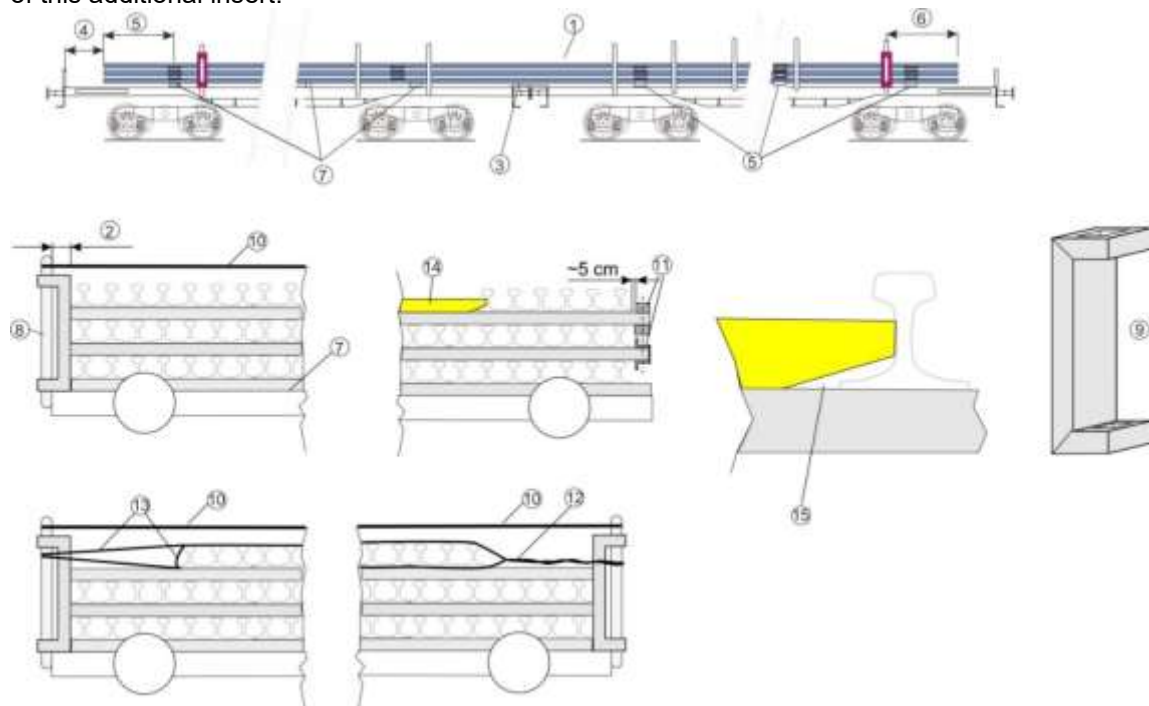

<sup>1)</sup> Reductions in clearance are permitted if they result from carriage in accordance with ④.

## 1.8.4

### Securing

The rails are secured

- ⑧ - at the sides by stanchions
- ⑨ - at each end by spacers attached to the stanchions such that they cannot pivot.
- ⑩ - The stanchions equipped with spacers must be double-bound with a woven or synthetic strap (LC= 1000 daN; pretensile force approx. 200 daN).  
The wooden supporting scotches attached to the wagon floor and the supporting timbers on the bolsters<sup>2)</sup> are nailed to the wagon floor or studded with steel spikes sticking into the wagon floor.
- ⑪ Lateral displacement of the inserts is limited by plywood scotches (compliant with EN 338, minimum strength class C24) or metal angles attached to the inserts (threaded rods with nuts) at a distance of approx. 5 cm from the base of the rails.

Incomplete upper tiers are to be secured above the spacers:

- ⑫ - in a central position using double-strand metal wire bindings (diameter 5 mm min.) **or**
- ⑬ - using straps tensioned in opposing directions (minimum breaking strength<sup>3)</sup>: 4000 daN min.) **or**
- ⑭ - using chamfered scotches (may not touch the rail base ⑮) attached to the inserts: in the loading spaces, centrally along the length of the wagon,
  - with at least two evenly-spaced nails of diameter approx. 5 mm, nailed in to a depth of at least 40 mm **or**
  - two screws minimum size M 10

### Additional indications

Load of wagons: see information sheet 0.1,

The wagons are loaded up to 85 % of the load limit of the wagon and the line on which they are to run (category of line).

The maximum load on each wheelset (see volume 1 number 3.3.) must not be exceeded.

Maximum dimensions of loads: see information sheet 0.2,

Single-use bindings: see information sheet 0.6

---

<sup>2)</sup> To comply with ③, supporting timbers of the appropriate size may be attached to the bolsters. These should have rectangular cross-sections and rest on their broader side.

<sup>3)</sup> Minimum breaking strength in tangent traction is equivalent to twice the permissible traction strength (LC) and only applies to synthetic straps, woven straps and load-securing straps, as well as lashing steel wire ropes and lashing chains.



## 1.8.5 Rails (loaded on several flat wagons)

Single wagons and groups of wagons

Wagons in block trains or combined transport  
Wagons with long-stroke shock absorbers

### Type of goods

Rails measuring longer than 36 m up to 180 m

### Wagons

Flat wagons with bogies, high-strength side stanchions (moveable stanchions with an I profile), collapsible end boards and wooden floor (Samms). Loading surfaces mostly at the same level.

Screw couplings must be tightened to ensure that the buffers are slightly compressed.

### Method of loading

- ① The rails may be loaded on top of one another, up to 3 full tiers resting on supporting scotches and wooden inserts. Incomplete tiers are only permitted at the top of the load.

Stanchions positioned ahead of the first and after the last spacer shall be removed.

Clearance from:

- ② - side stanchions without spacers: approx. 10 cm,  
 ③ - collapsed end boards and wagon floor (vertical distance): at least 5 cm,  
 ④ - collapsible end boards of end wagons, according to rail length:

Length of rail	Min. clearance
Up to 60 m	75 cm
> 60 m to 90 m	100 cm
> 90 m to 120 m	125 cm
> 120 m to 180 m	150 cm

- ⑤ The ends of the rails shall project beyond:

- the end spacers,
  - the supporting scotches and
  - the inserts
- by 1.5 to 3 m.

- ⑥ The supporting scotches shall be of a single wooden piece (compliant with EN 338, minimum strength class C24). Their cross-section shall be approx. 18 x 15 cm or 15 x 10 cm. They shall be distributed evenly along the load:

- two supporting scotches per wagon,
- each of which shall be placed above the bogie pin of the vehicle or at a uniform distance of up to 1 m towards the inside of the wagon. The supporting scotches shall be fastened, nailed to the wagon floor or on bolsters with stop plates (four nails distributed evenly, Ø 5 mm, minimum penetration depth: 40 mm).
- for at least half of the wagons in the transport unit, measures likely to reduce the friction coefficient are not permitted on the sliding surfaces of supporting scotches positioned at wagon centres.

- ⑦ Inserts (four at least per tier and per wagon):

- shall be of a single piece (compliant with EN 338, minimum strength class C24) with a cross-section of approx. 14 x 8 cm,
- shall also be equipped with flat steel sides with welded end pieces or steel corner pieces with a minimum height of 5 cm, screwed in place on either side from the top and bottom,
- shall be distributed evenly lengthways along the wagon and in the same area as the supporting scotches, at an equal distance from the nearest stanchions or spacers.

- ⑧ The width of the bearing surface of the inserts shall project by 12 to 16 cm beyond the width of the entire tier of rails.

- ⑨ The tips of the stanchions with spacers must be bound together by a double binding consisting of straps (LC=1,000 daN; pre-tensile force approx. 200 daN) or by double steel wire (Ø 5 mm).

## 1.8.5

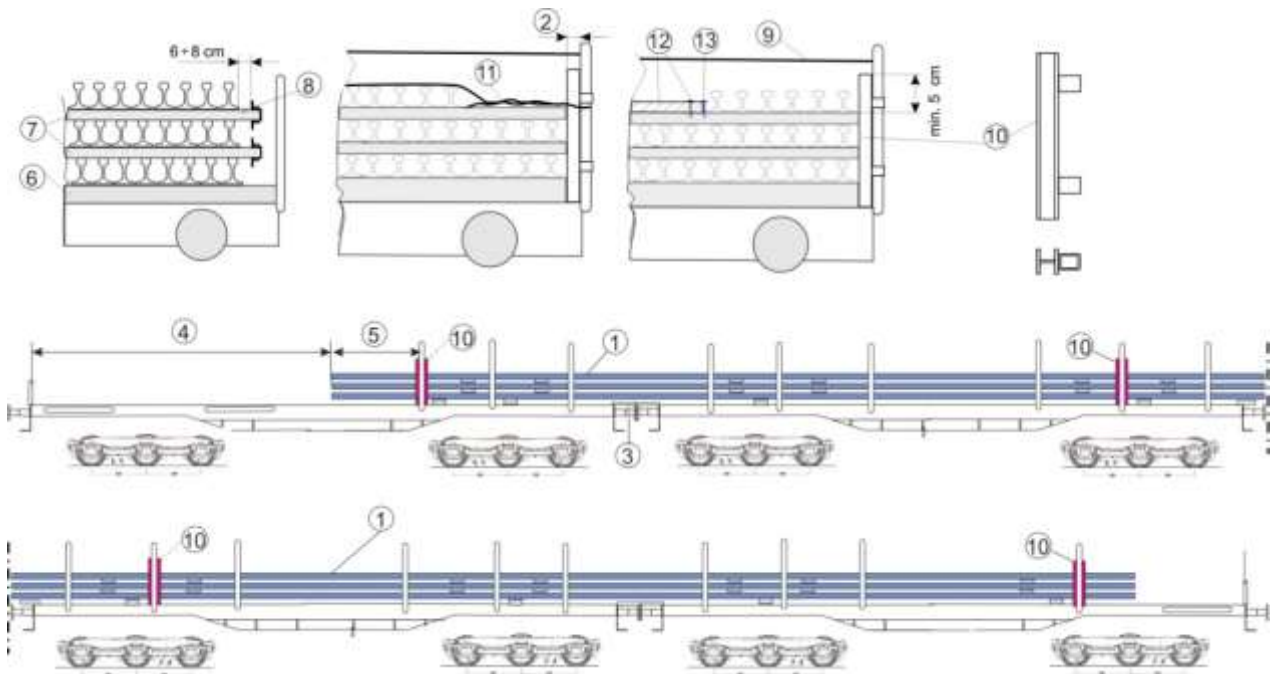

### Securing

The rails shall be laterally secured by means of:

- ⑩ - several spacers made of steel profiles (large "I" beams I-100, as per EN 10034), secured to specific stanchions so as not to pivot and projecting beyond the top tier of rails by approx. 5 cm. The first and last spacers may be secured to any stanchions (albeit in accordance with points ④ and ⑤) of the first and last wagon. On the other wagons, spacers shall always be secured to the stanchion above the pin of the second bogie of the next wagon. Spacers shall be secured to stanchions that are neither damaged nor bent, from the front and the back, moving towards the centre of the transport unit.  
A wagon positioned at the centre of the transport unit does not have to be equipped with spacers. Any upper, incomplete tier of rails must in all cases be secured next to the spacers.
- ⑪ - twin wire bindings (Ø 5 mm min.) in a central position, **or** blocks,
- ⑫ - positioned centrally on the longitudinal axis of the wagon in the intermediate spaces, secured by at least two nails distributed evenly, Ø approx. 5 mm, penetration of at least 40 mm, **and**
- ⑬ - protected against being torn out by at least two nails on each side of the rail.

### Additional indications

Load of wagons: see information sheet 0.1,

The wagons are loaded up to 85 % of the load limit of the wagon and the line on which they are to run (category of line).

The maximum load on each wheelset (see volume 1 number 3.3.) must not be exceeded.

Single-use bindings: see information sheet 0.6.

Hump and fly-shunting prohibited for these consignments.

Consignments considered as exceptional consignments by CFR, NRIC, Network Rail, GySEV, RFI, HŽ-Infrastruktura, SŽ-Infrastruktura, IŽS, ÖBB Infrastruktur, PKP PLK, ADIF, TRAFIKVERKET, Infrabel, SNCF Réseau and TCDD, and as normal consignments in block trains by the other members.

## 1.8.6 Rails on one wagon, loaded in staggered formation

Single wagons and groups of wagons

Wagons in block trains or combined transport  
Wagons with long-stroke shock absorbers

### Type of goods

Rails with identical cross-sections loaded in staggered formation on a wagon.

### Wagons

Wagons with walls, boards or stanchions and wooden floor or wooden bolsters.

### Method of loading

Rails loaded symmetrically crossways, and which must be loaded in staggered formation lengthways in order to optimise the maximum load capacity of the wagon.

- ① Stacks of rails loaded directly on the wagon floor, on bolsters or supporting scotches.

Rails loaded:

- ② - in several tiers, if possible covering the entire width of the floor  
③ - to the greatest possible degree at a right angle to the rails of the underlying tier.  
④ - to the greatest degree up to the top of the wall, board or stanchion.

The number of inserts and supporting scotches shall be chosen in order to ensure that the stacks are stable.

- ⑤ Wooden inserts and wooden supporting scotches (compliant with EN 338, minimum strength class C24)

- with a rectangular cross-section, resting on the broader face,
- in a single piece resting on the entire width of the stack (thickness: 4 cm).

- ⑥ The rails shall project beyond the inserts and supporting scotches by at least 50 cm.

Minimum clearances:

50 cm

0 cm

- If this distance cannot be complied with because the load is concentrated, compliance with the clearance requirements may be dispensed with, in accordance with the UIC Loading Guidelines, volume 1, number 5.5.3.

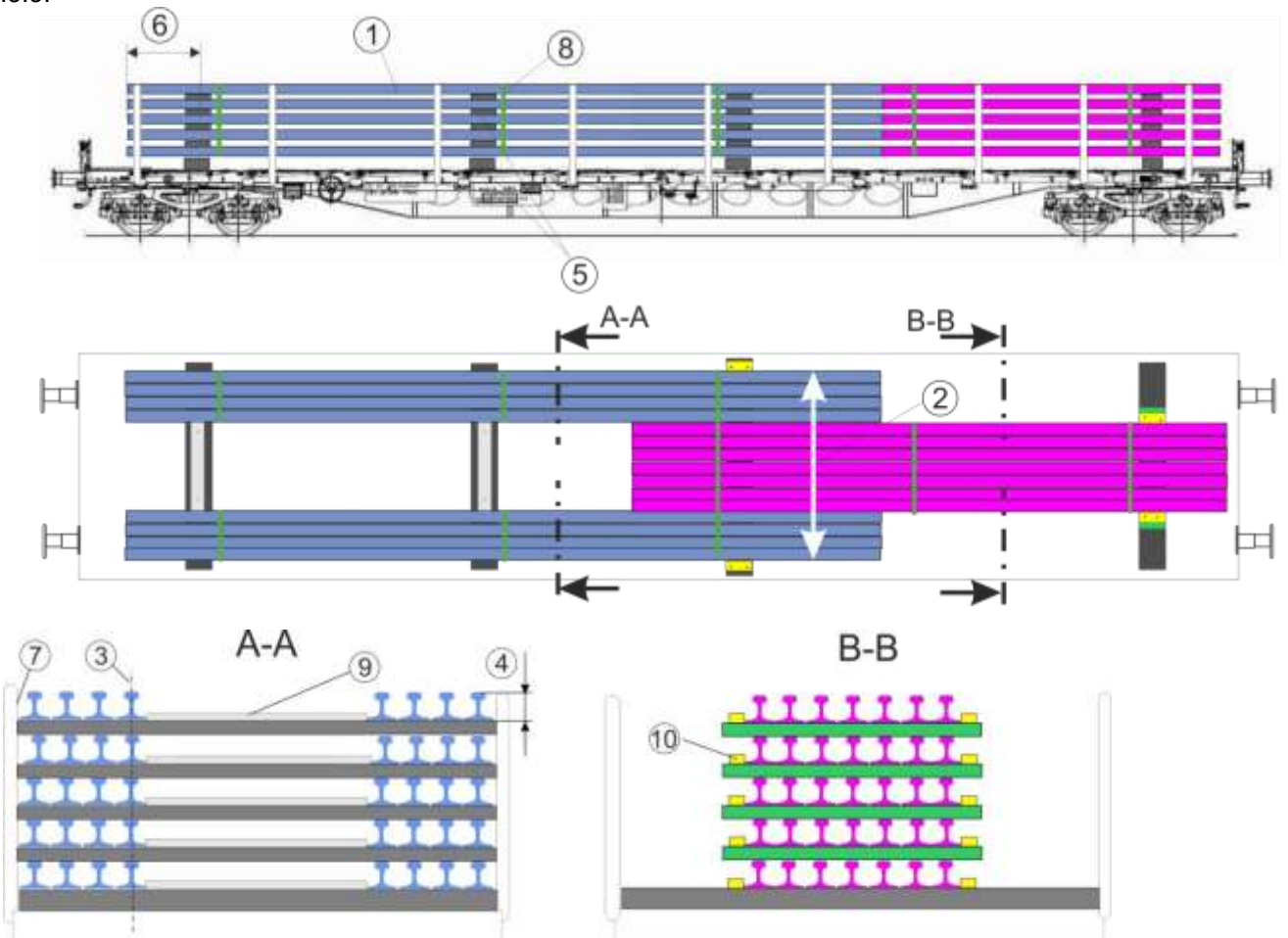

## 1.8.6

### Securing

The rails shall be:

⑦ secured directly by the walls, boards or stanchions.

In case of gaps at the side greater than 10 cm:

⑧ - stacks shall be bound as units, with one binding per 6 m long stack section or part thereof (min. two bindings per stack), min. breaking strength<sup>1)</sup> (straight pull) 1400 daN. Bindings shall be at a distance of at least 30 cm from the ends of the stacks.

⑨ - central gaps must be filled by means of nailed wooden pieces.

⑩ Wooden supporting scotches / inserts shall be secured against lateral movement by means of:

- supporting scotches nailed to the wagon floor,
- stop blocks nailed to the middle of the load on the inserts, or
- stop blocks nailed to the sides.

### Additional indications

Load of wagons: see information sheet 0.1,

Single-use bindings: see information sheet 0.6

---

<sup>1)</sup> The minimum breaking strength (straight pull) corresponds to double the permitted tensile force (LC); this concerns only synthetic straps, woven straps and load securing straps, as well as lashing steel wire ropes and lashing chains.

## 1.9.1 Aluminium slabs

Single wagons and groups of wagons

Wagons in block trains or combined transport  
Wagons with long-stroke shock absorbers

### Type of goods

Rough-surfaced aluminium slabs with in-built wooden inserts (grooved as per A), also of square cross-section, sharp edges on all sides, measuring min. 10x10 cm.

The inserts are bound to the aluminium slabs by means of:

- steel strips with a minimum breaking strength of 800 daN, **or**
- PET straps with a minimum breaking strength<sup>1)</sup> of 500 daN

If using PET straps, the attachment point must provide at least 80 % of the breaking strength (straight pull). The use of PP straps is not permitted.

- ① Distance between the ends of the slabs and the bindings: minimum 30 cm, maximum  $\frac{1}{3}$  of the length of the slab.

### Wagons

Flat wagons with bogies, stanchions and wooden or mixed-material (wood and steel) floor.

### Method of loading

Slabs with in-built wooden inserts, loaded directly onto the wagon floor.

- ② Anti-skid inserts must be placed between the load and the floor on mixed-material (wood and steel) floors. Slabs may be loaded one on top of the other or side by side.

Minimum clearances at wagon ends:

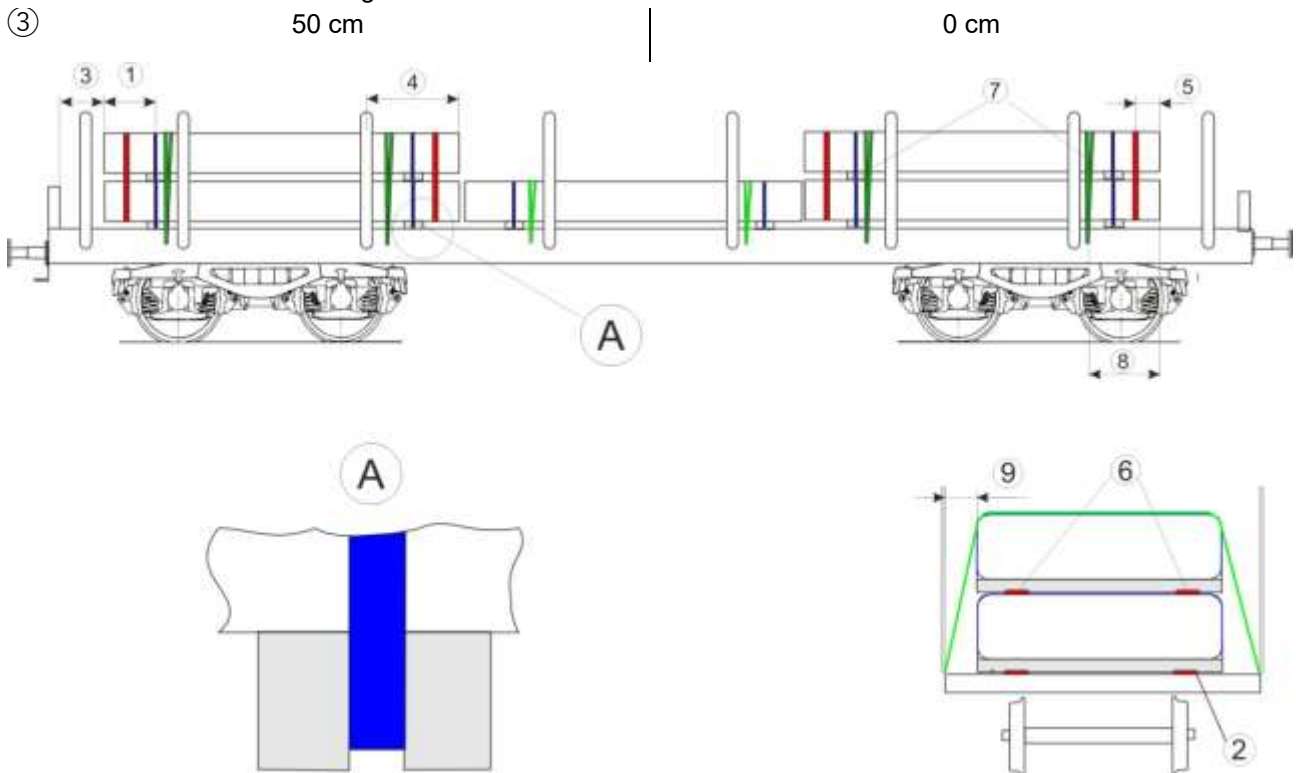

### Securing

If the load is secured by only two stanchions, the slabs shall protrude beyond these stanchions by at least:

- ④
- 50 cm
- 30 cm

- ⑤ Slabs stacked one on top of the other are to be bound together twice. The distance between the bindings and the ends of the slabs shall be approx. 30 cm and the breaking strength (straight pull), 3500 daN.

<sup>1)</sup> Minimum breaking strength (straight pull) is equivalent to twice the permissible tensile strength (LC) and only applies to synthetic straps, woven straps and load-securing straps, as well as lashing steel wire ropes and lashing chains.

### 1.9.1

- ⑥ If anti-skid materials are used, the minimum breaking strength of the bindings shall be 2000 daN. All load units are to be secured by at least two indirect fastenings. Breaking strength, straight pull, 3500 daN).
- ⑦ Distance between indirect fastenings and slab ends: minimum 50 cm. Straps to have edge protection against sharp edges.
- ⑧ Single-use bindings are to be passed over the load, then around it on either side via eyelets or other means of attaching them to the wagon body, then back over the top of the load, where they are to be attached to the tightening loop and tightened using the tensioning device.
- ⑨ The load is to be secured crosswise in the wagon by means of friction, indirect fastenings and stanchions, even if it is more than 10 cm from the stanchions/walls.

#### **Additional indications**

Load of wagons: see information sheet 0.1,

Single-use bindings: see information sheet 0.6,

Indirect fastenings: see information sheet 0.7,

Friction and coefficients of friction: see information sheet 0.8.

In accordance with the UIC Loading Guidelines, volume 1, point 5.5.3, clearance between the goods and the end-doors/-walls need not be provided when the goods conveyed are not sensitive to impact.

## 1.10.1 Metal trellis-work

Single wagons and groups of wagons

Wagons in block trains or combined transport  
Wagons with long-stroke shock absorbers

### Type of goods

- ① Metal trellis-work bound into stacks using at least two steel wire bindings of diameter at least 4 mm.

### Wagons

Wagon with stanchions and wooden floor

### Method of loading

- ② Stacks in several tiers loaded directly onto the floor, on bolsters or wooden timbers.  
③ Minimum clearances at wagon ends:

30 cm

0 cm

- ④ Stacks loaded higher than the top of the stanchions should be inset by a further 10 cm on top of the usual width reductions, in order not to foul the loading gauge (sway of load).

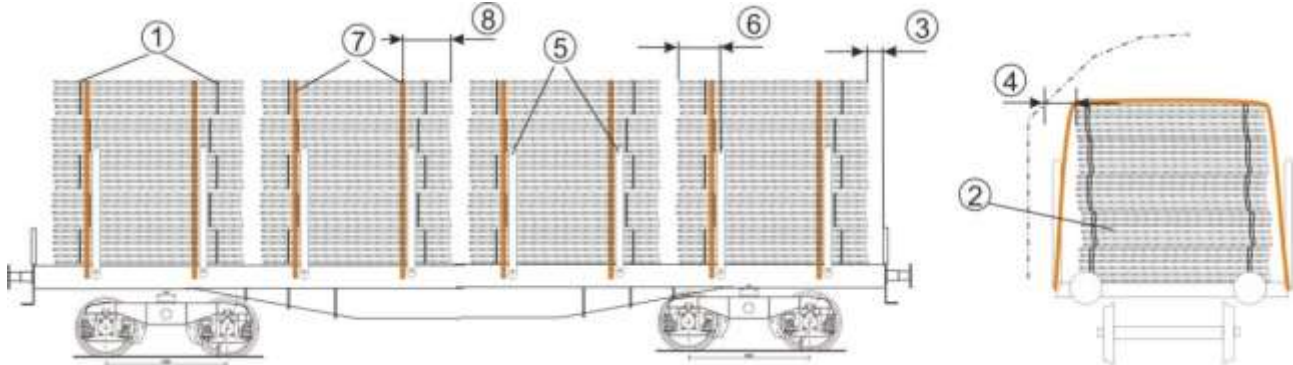

### Securing

- ⑤ Stacks are secured by the stanchions.  
⑥ When secured by two stanchions only, stacks must extend beyond the centre of the stanchions by at least:

30 cm

20 cm

- ⑦ Stack indirectly fastened using at least two straps:  
⑧ - Distance from end of stack around 50 cm,  
- Type of binding: woven straps with edge protection and tensioning device (breaking strength<sup>1)</sup> at least 4000 daN) or  
- steel cord (min. Ø 8 mm) with tensioning device.

### Additional indications

Load of wagons: see information sheet 0.1

Maximum dimensions of loads: see information sheet 0.2

Single-use bindings: see information sheet 0.6,

Indirect fastenings: see information sheet 0.7.

<sup>1)</sup> The minimum breaking strength (straight pull) corresponds to double the permitted tensile force (LC); this concerns only synthetic straps, woven straps and load securing straps, as well as lashing steel wire ropes and lashing chains.



## 1.10.2 Wire netting in rolls

Single wagons and groups of wagons

Wagons in block trains or combined transport  
Wagons with long-stroke shock absorbers

### Type of goods

Wire netting in rolls bound with at least two steel wire bindings of min 4 mm diameter

### Wagons

Wagons with walls or side and end stanchions and sides and wooden floor

### Method of loading

Rolls should be loaded

- ① - directly onto the wagon floor,
  - crosswise in the wagon,
  - in several dovetailed tiers.
- ② Rolls loaded higher than the tops of the stanchions should be inset by a further 10 cm in relation to the loading gauge (swaying of load)

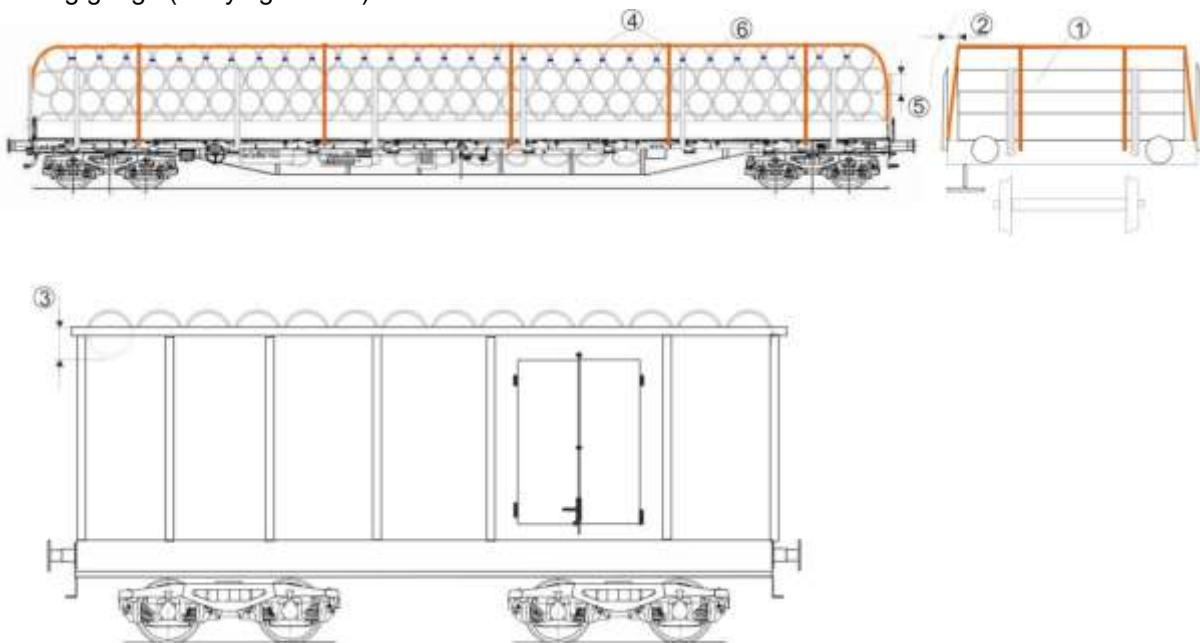

### Securing

Rolls should be secured as follows

- ③ - by the sides of wagons with at least half the diameter of the rolls held by the sides,
  - on wagons with stanchions:
- ④ • by fastenings, at least two lengthways and at least one every 3 m crossways. Crossways fastenings should lie over the lengthways fastenings (fastenings should have a breaking strength<sup>1)</sup> of at least 1000 daN).
- ⑤ • rolls resting against the end stanchions should be secured by the stanchions up to at least half the diameter of the rolls.
- ⑥ • rolls in the top tier should be bound together with two steel wire fastenings of 4 mm diameter.

### Additional indications

Load of wagons: see information sheet 0.1

Maximum dimensions of loads: see information sheet 0.2

Single-use bindings: see information sheet 0.6,

Indirect fastenings: see information sheet 0.7.

<sup>1)</sup> The minimum breaking strength (straight pull) corresponds to double the permitted tensile force (LC); this concerns only synthetic straps, woven straps and load securing straps, as well as lashing steel wire ropes and lashing chains.



### 1.10.3 Wire netting in rolls and in bundles

Single wagons and groups of wagons

Wagons in block trains or combined transport  
Wagons with long-stroke shock absorbers

#### Type of goods

Wire netting bound with at least two steel wire bindings of min 4 mm diameter (bundles and rolls)

#### Wagons

Wagons with walls or stanchions (side and end stanchions) and sides

#### Method of loading

- ① Bundles should be loaded directly onto the wagon floor or on wooden timbers
- ② Rolls should be loaded crosswise in the wagon in several dovetailed tiers
- ③ Rolls loaded higher than the tops of the stanchions should be inset by a further 10 cm in relation to the loading gauge (swaying of load)

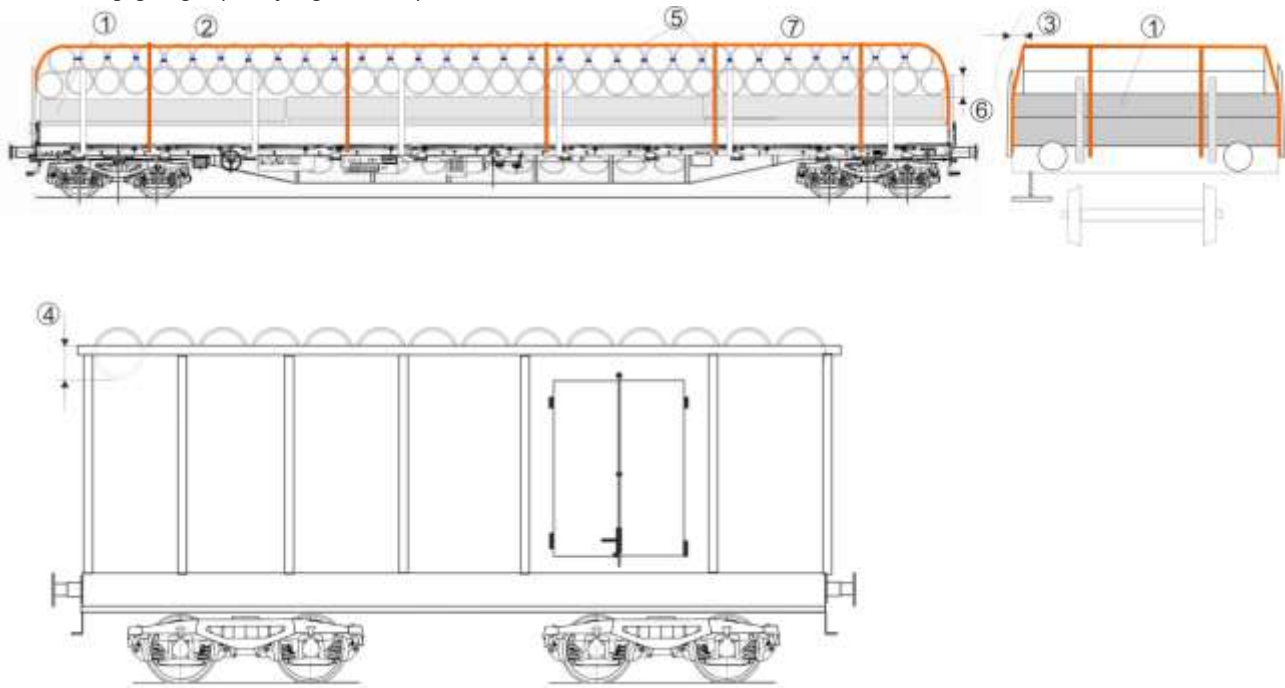

#### Securing

Rolls should be secured as follows

- ④ - by the sides of wagons with at least half the diameter of the rolls held by the sides,  
- on wagons with stanchions:
- ⑤
  - by tautly drawn fastenings, at least two lengthways and at least one every 3 m crossways. Crossways fastenings should lie over the lengthways fastenings (fastenings should have a breaking strength<sup>1)</sup> of at least 1000 daN)
- ⑥
  - rolls resting against the end stanchions should be secured by the stanchions up to at least half the diameter of the rolls.
- ⑦
  - rolls in the top tier should be bound together with two steel wire fastenings of 4 mm diameter.

#### Additional indications

Load of wagons: see information sheet 0.1

Maximum dimensions of loads: see information sheet 0.2

Single-use bindings: see information sheet 0.6,

Indirect fastenings: see information sheet 0.7.

<sup>1)</sup> The minimum breaking strength (straight pull) corresponds to double the permitted tensile force (LC); this concerns only synthetic straps, woven straps and load securing straps, as well as lashing steel wire ropes and lashing chains.



## 1.10.4 Coils of wire rod (all diameters) loaded gunshot

Single wagons and groups of wagons

Wagons in block trains or combined transport  
Wagons with long-stroke shock-absorbers

### Type of goods

Coils of wire rod

- any diameter of wire
- diameter of coils between 1100 and 1300 mm
- length: 1100 to 2400 mm
- unit mass: 1100 to 2400 kg

- ① Special care should be taken when compacting the coils. Each coil should be held together with at least four bindings (minimum breaking strength 1400 daN), regularly spaced around the whole circumference of the coil.

No bindings should be loose or broken.

### Wagons

Flat wagons with wooden floor, stanchions and side walls

### Method of loading

The coils of wire rod should be loaded lengthways in the wagon ("gunshot")

- ② - Directly onto the wagon floor, in two rows arranged either side of the longitudinal centreline of the wagon
- ③ - in contact with the wagon side walls or set back slightly from them
- ④ - with an upper tier dovetailed between the two lower tiers. This dovetailed tier must be inset 50 cm from the ends of the lower tiers.

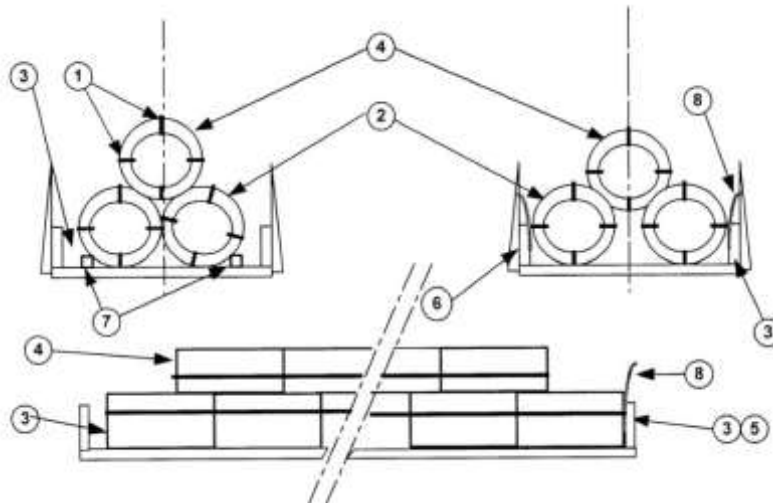

### Securing

Lengthways in the wagon:

- ⑤ - by the end boards

Crossways in the wagon:

- ⑥ - coils in the lower tiers are in contact with the wagon side walls or
- ⑦ - set back from them if the coils are secured using nailed-down timbers (minimum cross-section 90 x 90cm)

### Additional indications

- ⑧ Depending on the quality of the product, some form of protection (cardboard, plastic, etc.) may be necessary between the coils and the wagon side walls

Load of wagons: see information sheet 0.1



## 1.10.5 Coils of wire rod loaded on the roll

Single wagons and groups of wagons

Wagons in block trains or combined transport  
Wagons with long-stroke shock-absorbers

### Type of goods

Coils of wire rod

- diameter of wire 9 mm
- diameter of coils between 1100 and 1300 mm
- length: 1100 to 1320 mm
- unit mass: 1100 to 1350 kg

- ① Special care should be taken when compacting the coils. Each coil should be held together with at least four bindings (minimum breaking strength 1400 daN), regularly spaced around the whole circumference of the coil. No bindings should be loose or broken.

### Wagons

Flat wagons with wooden floor, stanchions and side walls

### Method of loading

The coils of wire rod should be loaded

- ② - on the roll, directly onto the wagon floor, either side of the longitudinal centreline of the wagon  
 ③ - in contact with the wagon side walls  
 ④ - in contact with the wagon end boards  
 ⑤ - with an upper tier of coils dovetailed between the two lower tiers, centred on the wagon centreline.

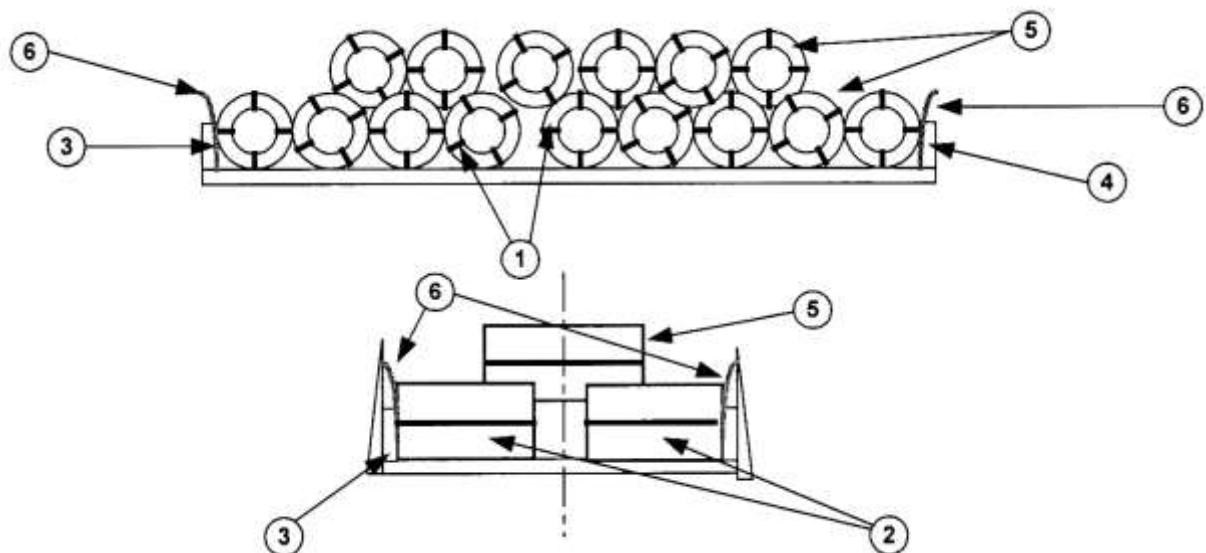

The first position (i.e. next to the end boards) should be left free.

### Additional indications

- ⑥ Depending on the quality of the product, some form of protection (cardboard, plastic, etc.) may be necessary between the coils and the wagon side walls.

Load of wagons: see information sheet 0.1.



## 1.10.6 Coils of wire rod loaded on the roll in two tiers

Single wagons and groups of wagons

Wagons in block trains or combined transport  
Wagons with long-stroke shock-absorbers

### Type of goods

Coils of wire rod -diameter of wire:  $\leq 9$  mm

- diameter of coils between 1100 and 1300 mm
- length: 1400 to 2400 mm
- unit mass: 1400 to 2400 kg

- ① Special care should be taken when compacting the coils to ensure good stability. Each coil should be held together with at least four bindings (annealed steel wire or steel strip, breaking strength at least 1400 daN) regularly spaced around the whole circumference of the coil.

No bindings should be loose or broken.

### Wagons

Flat wagons with wooden floor, stanchions, side and end flaps.

Wagons with strengthened sliding walls (with the code letters ii) as listed in loading method 100.2.

### Method of loading

The coils of wire should be loaded ·

- ② - on the roll, the lower tier directly on the wagon floor, ·
- if there are spaces in the lower tier,
- ③ ·
- dovetailed keystone layer **or**
- ④ ·
- scotches nailed to the wagon floor,
    - height of scotches: at least 12 cm,
    - length of scotches:
      - one scotch of length roughly equivalent to  $\frac{3}{4}$  of the length of coil,
      - or**
      - two long scotches each of at least 30 cm, ·
  - six nails per scotch (six nails if a single scotch or three nails per 30 cm scotch min.),
- ⑤ - an upper dovetailed tier with the first position near each of the end flaps left free,
- ⑥ - The longest coils should be loaded in the bottom tier,
- ⑦ - All coils must be centred along the wagon's longitudinal axis.

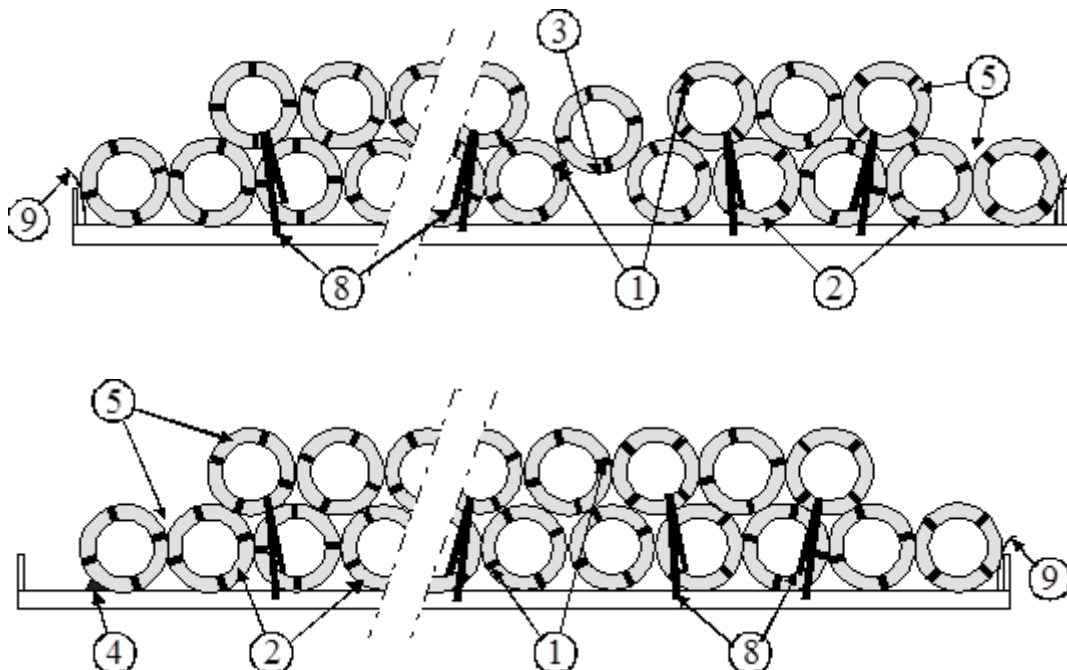

1.10.6

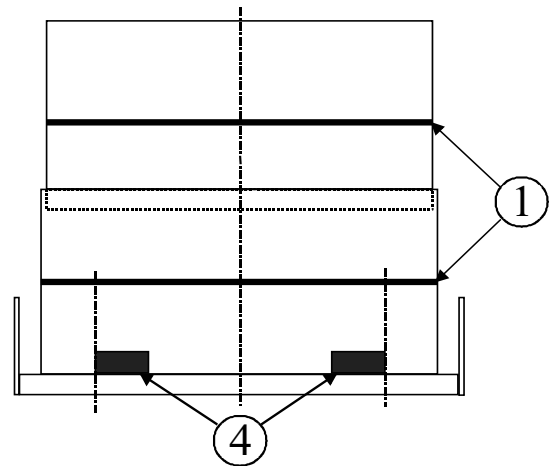
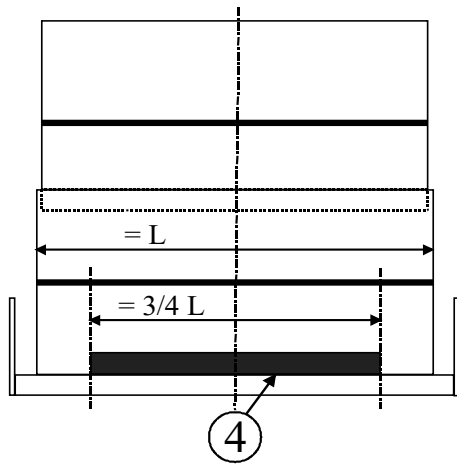
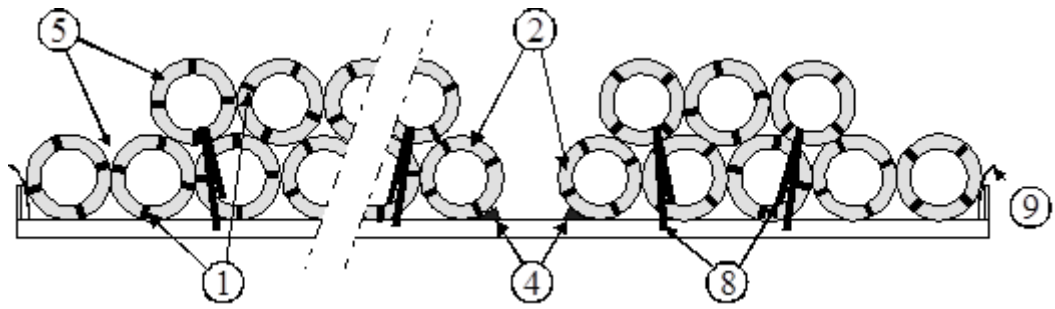

**Securing**

- ⑧ Four times with double load-securing straps (breaking strength<sup>1)</sup> at least 2200 daN) arranged in opposite directions and if possible, held with direct fastenings exerting an oblique tensile force.

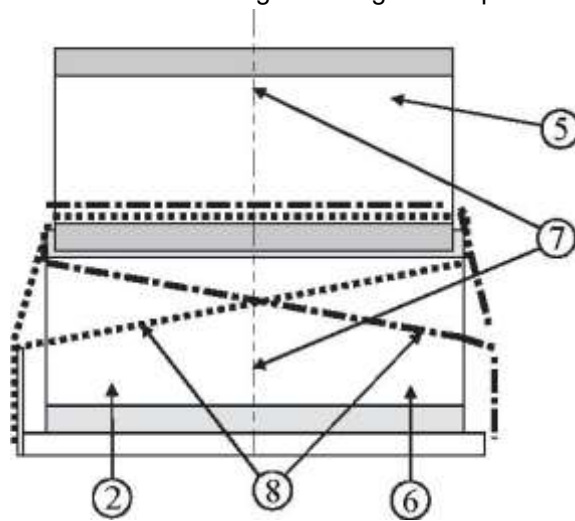

**Additional indications**

- ⑨ Depending on the quality of the product, protective dunnage (cardboard, plastic, etc.) can be placed between the coils and the wagon end flaps.

Load of wagons: see information sheet 0.1

Single-use bindings: see information sheet 0.6.

<sup>1)</sup> The minimum breaking strength (straight pull) corresponds to double the permitted tensile force (LC); this concerns only synthetic straps, woven straps and load securing straps.

## 1.11.1 Scrap

Single wagons and groups of wagons

Wagons in block trains or combined transport  
Wagons with long-stroke shock absorbers

### Type of goods

Scrap, loaded in bulk, e.g.:

- metal sheets (irrespective of size, surface area and thickness)
- sections of bodywork
- machine punchings
- offcuts
- mixture of scrap and heavy scrap
- crushed cars, etc.

### Wagons

Wagons with sides

### Method of loading

- ① Scrap should be evenly spread and loaded no higher than the top of the sides (including at the centre of the wagon).

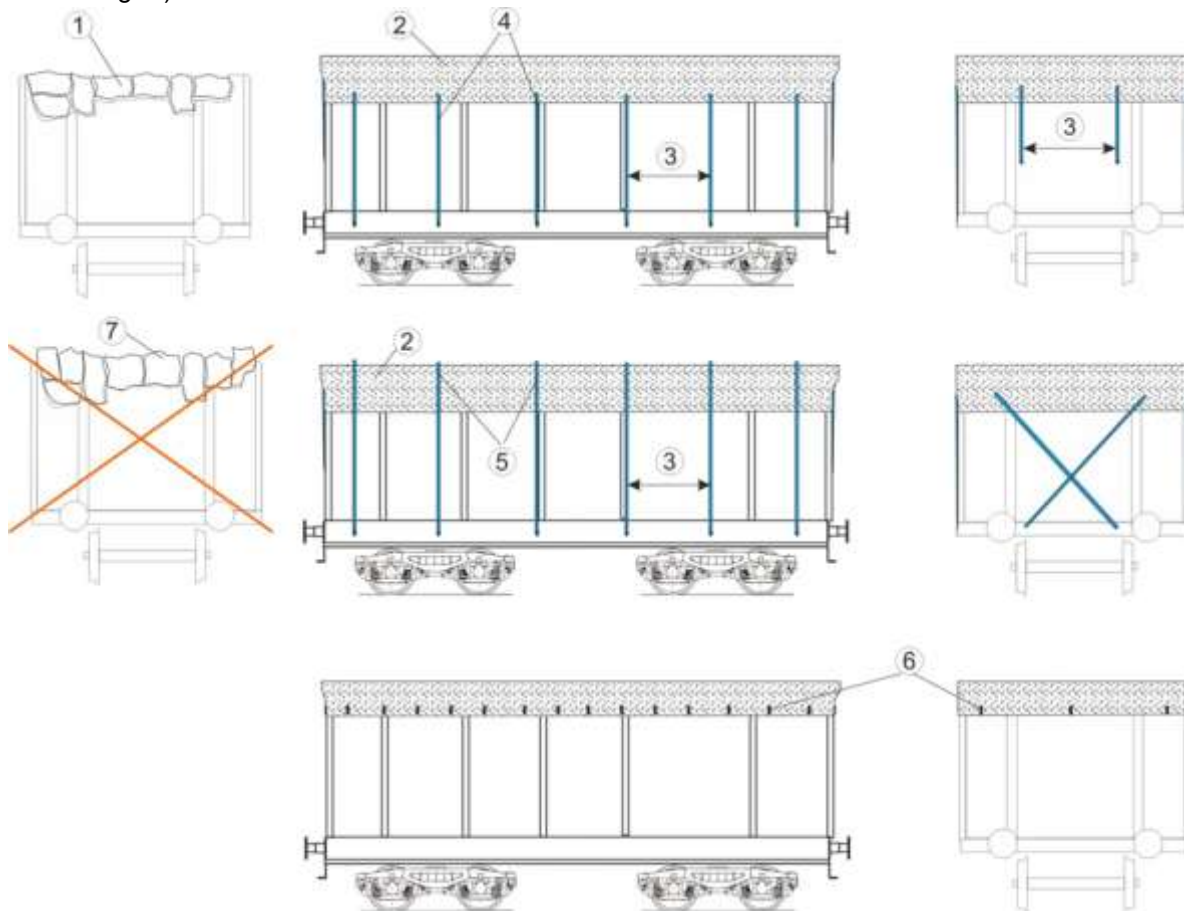

### Securing

- ② The scrap should be covered over its entire surface.

Covering material:

- metal trellis-work (standard chicken wire)
  - mesh of 100 mm maximum
- synthetic netting
  - width approx. 3.80 m
  - maximum mesh size 30 mm
  - longitudinal breaking strength at least 39 daN<sup>1)</sup>
  - transverse breaking strength at least 48 daN<sup>1)</sup>

<sup>1)</sup> Strength tests to be carried out on a sample 10 cm wide incorporating 3 threads

### 1.11.1

Covering material should be fastened approx. every 2 m

- ③ - to the end boards with non-metallic binding (for chicken wire, steel wire is also acceptable) or in accordance with ⑥, in which case the breaking strength<sup>2)</sup> of binding is approx. 50 daN

All the bindings are to be tied to the net itself or

- ⑤ - are stretched tight crossways over the net or
- ⑥ - the net is stretched tight and attached tautly to the wagon hooks (hooks are present on e.g. Eaos wagons).

Parts that could be blown up by relative winds or pressure waves, such as bonnets, must be loaded into the lower parts of wagons.

### Additional indications

- ⑦ Scrap should not be compressed or protrude to increase effective wall height.

During transit, loosening of the load beneath the net may cause it to protrude beyond the side walls. It must however be restrained in a sufficiently secure manner by the netting or the walls.

---

<sup>2)</sup> The minimum breaking strength (straight pull) corresponds to double the permitted tensile force (LC); this concerns only synthetic straps, woven-fabric straps and load securing straps, as well as lashing steel wire ropes and lashing chains.

## 1.11.2 Heavy scrap

Single wagons and groups of wagons

Wagons in block trains or combined transport  
Wagons with long-stroke shock absorbers

### Type of goods

Heavy scrap, loaded in bulk:

- cast iron pieces and fragments,
- shavings and chippings,
- segments of sectional iron and pipe offcuts,
- scrap iron from bodywork shredders,
- sections of rail and wrought iron,
- crushed scrap (briquettes),
- uncrushed motor cars, etc.

### Wagons

Wagons with doors or walls.

### Method of loading

Scrap should be evenly spread and loaded:

- ① no higher than approx. 10 cm from the top of the door or the wall (also in the centre of the wagon).
- ② crushed scrap (briquettes), uncrushed motor cars, etc.: may be loaded to approx. the top of the side door.
- ③ Parts liable to be lifted by wind or pressure waves, such as bonnets, must be loaded into the lower parts of wagons then covered with heavy scrap.

For heavy scrap loading mixed with other scrap, see loading method 1.11.1.

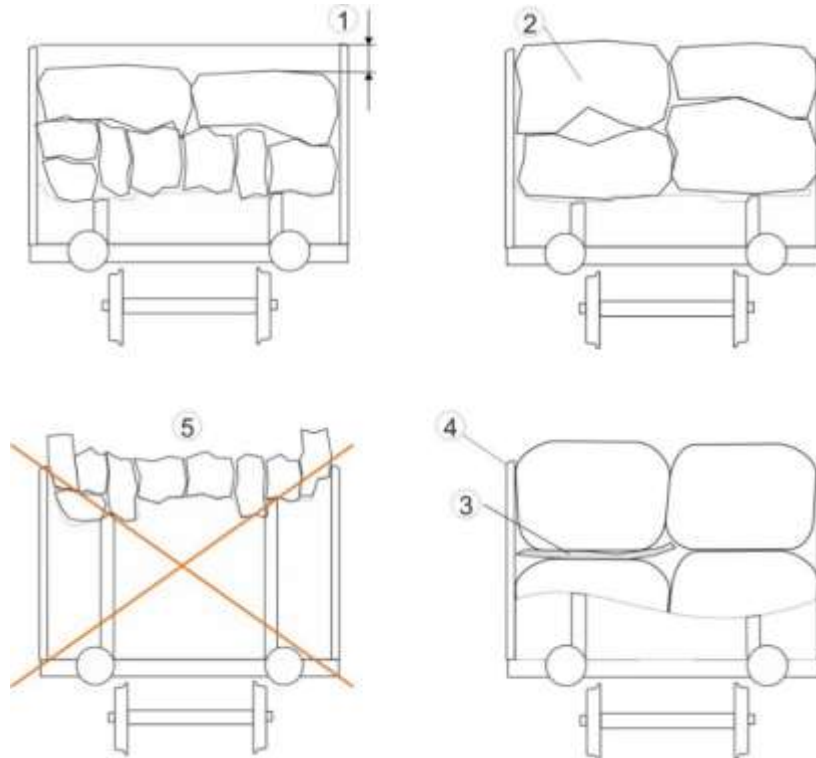

### Securing

- ④ By doors and walls.

### Additional indications

- ⑤ Scrap should not be compressed or loaded such as to increase the effective height of the doors or walls of the wagon. The forces exerted on the load during transit may cause it to protrude beyond the doors or the walls. It must still however be restrained in a sufficiently secure manner by the doors or the walls.

Load of wagons: see information sheet 0.1

Maximum dimensions of loads: see information sheet 0.2.



## Chapter 2: Wood



## 2.1 Rough logs

Single wagons and groups of wagons

Wagons in block trains or combined transport  
Wagons with long-stroke shock absorbers

### Type of goods

Rough logs<sup>1)</sup> with or without bark, of various sizes.

### Wagons

Wagons with walls, sides or stanchions.

### Method of loading

Logs

- should be loaded lengthways in the wagon,
  - ① - resting against the walls, sides or stanchions should project above them by no more than half their diameter,
  - for logs with a diameter of less than:
    - 20 cm: the effective height of the stanchions or side walls should be at least 10 cm,
    - 10 cm: load only under the highest tier that is resting against the stanchions or side walls
  - When dovetailed in stable position above the walls or stanchions:
    - ③ • the diameter of the logs in the dovetailed tier must not exceed that of the logs in the supporting tier,
    - ④ • the height of the cone formed by the logs must not exceed  $\frac{1}{3}$  of the load width.
- If logs rest above half the height of the stanchions:
- ⑤ - swivelling stanchions should be scotched or
  - ⑥ - stanchions should be bound with double-strand wire ( $\varnothing$  4 mm) or straps (breaking strength at least 1000 daN) about halfway up the stanchion.

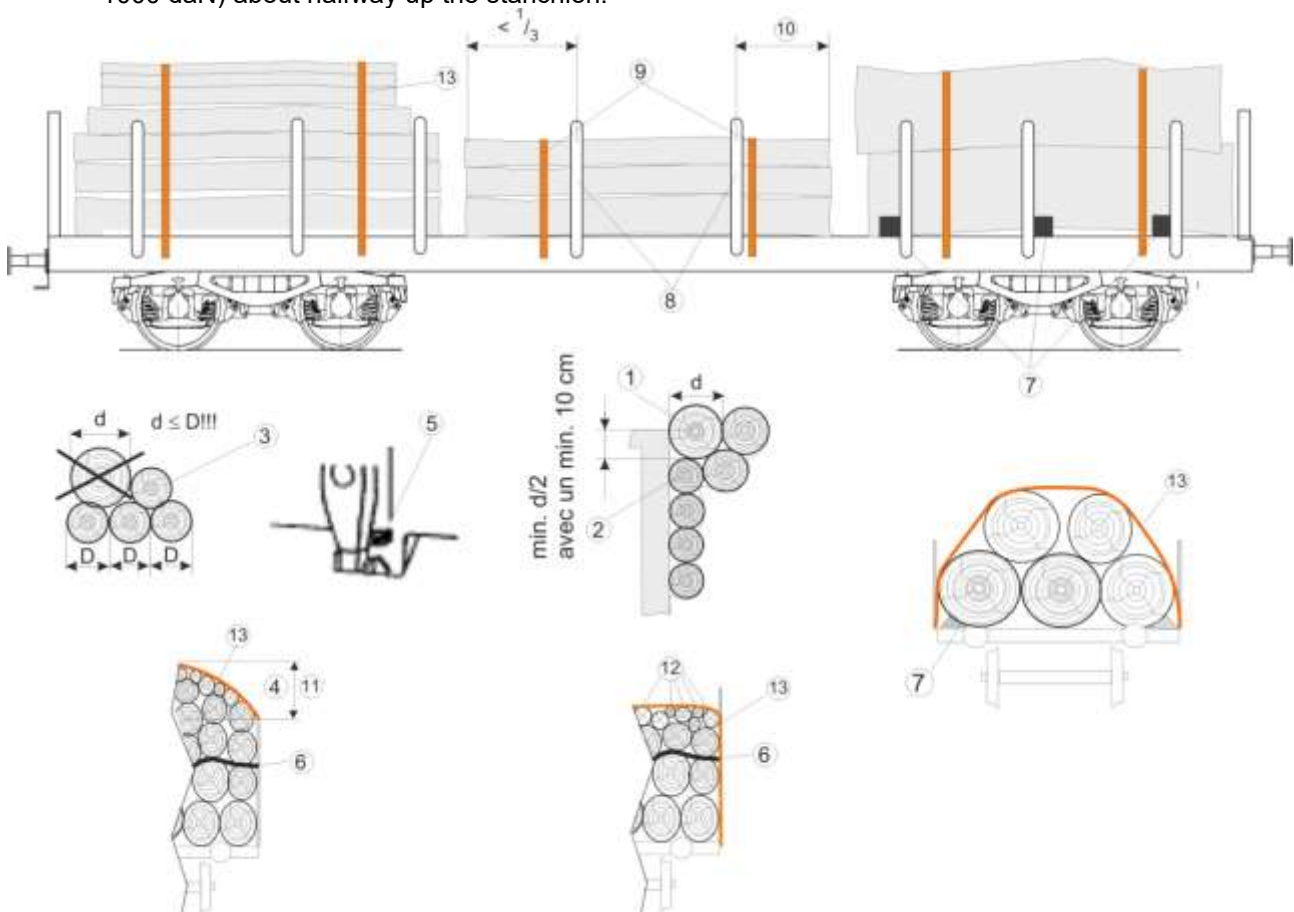

<sup>1)</sup> Logs with smooth surface on GC: only on wagons with fixed and very high-end walls

## 2.1

### Securing

⑦ Logs of over 70 cm in diameter (measured at the thinnest end) loaded on K., L. and R. wagons should be laterally secured with at least three scotches at least 12 cm high, with at least three nails ( $\varnothing$  approx. 5 mm) per scotch and at least two indirect fastenings ⑬ (minimum breaking strength: 1000 daN).

No scotching of swivelling stanchions (⑤), binding of stanchions (⑥) or scotching of logs (⑦) are required on wagons with high-strength stanchions as per UIC Leaflet 577, point 4.4.3. These wagons are indicated by the "II" marking or are listed in the loading guideline 100.3.

⑧ Logs resting against the stanchions shall be secured by at least two stanchions; stanchions are always positioned in every end third of the stacks.

When this condition cannot be complied with, an indirect fastening must be positioned towards each end

⑨ of the pile, approx. 50 cm from each of these ends. The stanchions specifically used to secure the load must be distant from one another by 80 cm, as measured from the central axis of the stanchion. Breaking strength<sup>2)</sup> of the indirect fastenings (straight pull): at least 4000 daN.

⑩ When secured by only two stanchions, logs should extend lengthways beyond the stanchion centres by at least:

50 cm		30 cm
for logs with rough bark, by at least:		
30 cm		20 cm

⑪ - dovetailed, stably loaded logs projecting above the walls or stanchions **or**

⑫ - logs in the topmost tier with  $\varnothing < 10$  cm

- which are not fully secured by the end walls,
- which are secured by side stanchions

⑬ should be secured by one indirect fastening for every 6 m of the stack length started, and by at least two indirect fastenings overall (e.g. load-securing straps with breaking strength at least 1000 daN).

The distance between the fastenings:

- and the ends of the logs should be around 50 cm.
- On wagons equipped with indirect fastening devices, the distance between the fastenings and the logs may exceed 50 cm depending on the design of the wagon. In such cases, the fastenings must have a minimum breaking strength of 4000 daN.

### Additional indications

Load of wagons: see information sheet 0.1

Maximum dimensions of loads: see information sheet 0.2

Single-use bindings<sup>2)</sup>: see information sheet 0.6,

Indirect fastenings<sup>2)</sup>: see information sheet 0.7.

<sup>2)</sup> The minimum breaking strength (straight pull) corresponds to double the permitted tensile force (LC); this concerns only synthetic straps, woven straps and load securing straps, as well as lashing steel wire ropes and lashing chains.

## 2.2.1 Square-sawn rough timber in packages

Single wagons and groups of wagons

Wagons in block trains and combined transport  
Wagons with long-stroke shock absorbers

### Type of goods

Square-sawn timber in compact packages<sup>1)</sup> with a rectangular cross-section and, if necessary, stabilising scotches inserted into the packages, with or without packing.

- ① Stabilising scotches with a maximum thickness of 15 mm may be inserted into the package. They may not be inserted between each tier. The stabilising scotches at the ends of the packages must be placed where the end bindings of the package are located.

The stabilising scotches may be inserted every two tiers at most, depending on the thickness of the sawn timber.

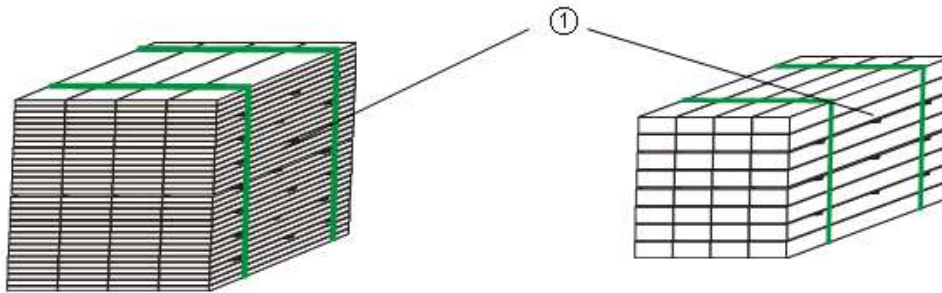

Packages up to 4.5 m long are bound by two bindings at least, with an additional binding every time a new section of 1.5 m is started.

- ② When drying scotches are used inside the packages: three bindings at least and an additional binding every time a new section of 1.5 m is started. The end bindings are placed above or immediately next to the drying scotches.
- ③ The end bindings are distant by at least 30 cm from the ends of the package.

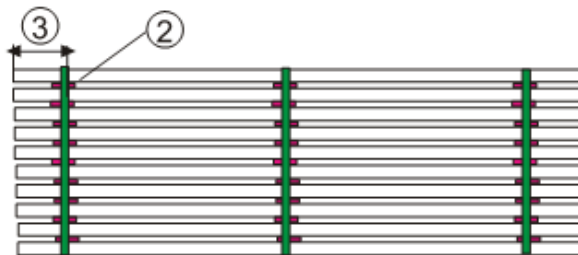

Breaking strength of the package bindings (straight pull): 700 daN; the attachment point, in case of PET straps, must ensure at least 80% of the breaking strength (straight pull). Minimum pre-tensile force: 300 daN.

Steel wire or PP straps may not be used.

### Wagons

- Flat wagons with stanchions and wooden floors or in-built bolsters, or with anti-skid materials, with or without collapsible boards, with or without mechanical sheeting,
- Wagons with metallic sliding walls or hoods.

<sup>1)</sup> If the packages are not compactly bound, they shall be transported only on wagons with metallic sliding walls or hoods.

## 2.2.1

### Method of loading

The packages should be loaded side by side and one behind the other. Packages with the same dimensions should, where possible, be arranged side by side and on top of one another or, where appropriate, any individual packages may be placed in the middle of the top tier on underlying packages of equal height. Packages of unequal length should be loaded as compactly as possible.

Loading:

- ④ - at least two wooden supporting scotches (bolsters) and the same number of wooden inserts in a single piece (see also ⑤), covering the entire width of the load. Even if the packages include in-built supporting scotches, at least two wooden inserts or supporting scotches made of a single piece running all the way through the package must be added (see also ⑤).
- ⑤ - supporting scotches or wooden inserts with a rectangular cross-section resting, on their larger side, on at least  $\frac{3}{4}$  of the bearing surface, may consist of several pieces of equal thickness overlapping each other laterally in each case (at least 50% of each part rests on the underlying package). In this case the number of pieces may not exceed the number of packages resting side by side.
  - individual packages loaded one behind the other in the centre of the topmost layer must be positioned on inserts at least  $\frac{2}{3}$  as long as the lower layer is wide.
- ⑥ - In case of sections with a square cross-section measuring at least 6 x 6 cm, the timbers must have sharp edges on all sides over at least  $\frac{3}{4}$  of the bearing surface.
  - The supporting scotches or wooden inserts consisting of several superimposed pieces must be sufficiently secured and cover the entire width of the load in a single block.
- ⑦ The wooden supporting scotches and inserts must, as far as possible, rest on top of one another at a distance of approx. 50 cm from the package ends. For thicknesses of 40 mm and more, a distance of up to 100 cm from the package ends is permitted.

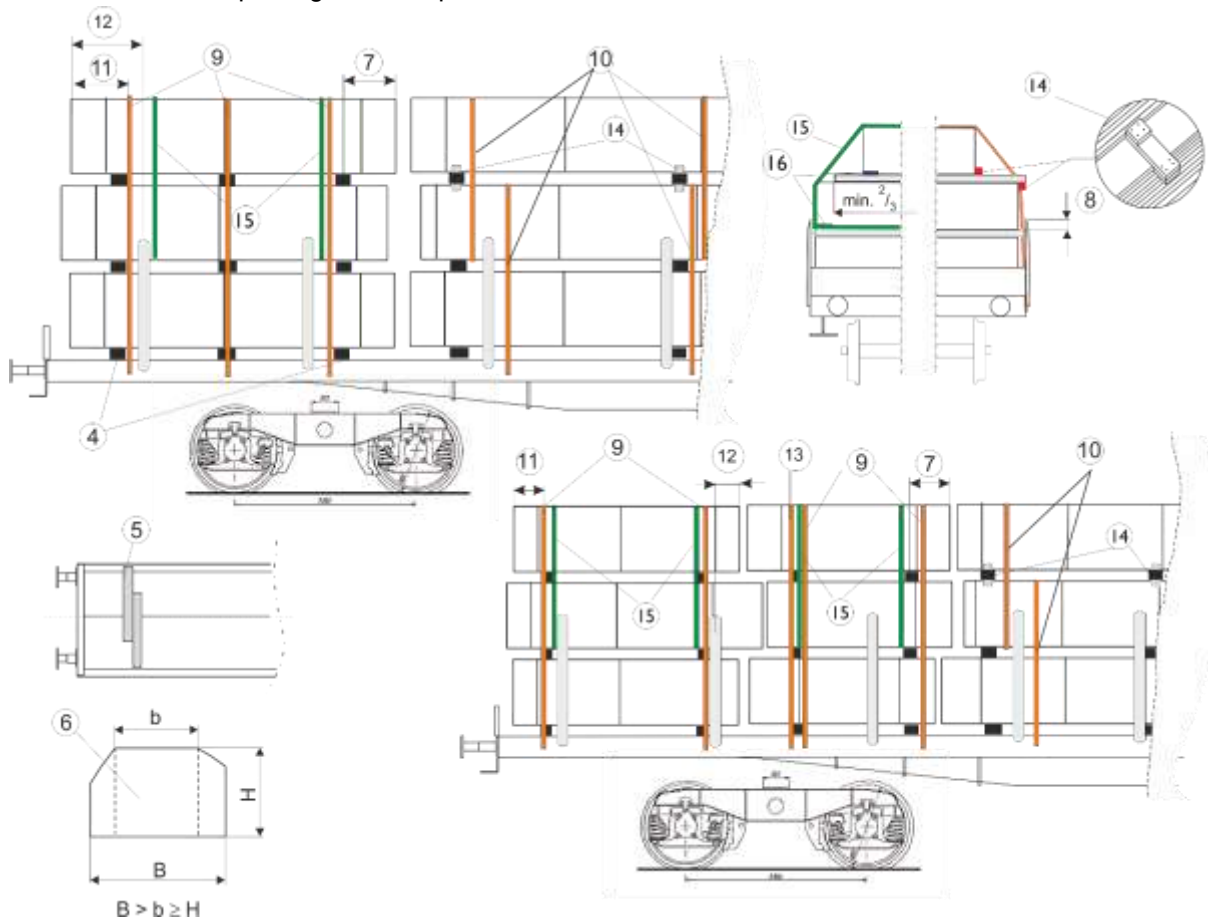





## 2.2.2 Square-sawn smooth timber (planed, precision-sawn) in packages

Single wagons and groups of wagons

Wagons in block trains and combined transport  
Wagons with long-stroke shock absorbers

### Type of goods

Square-sawn timber in compact packages<sup>1)</sup> with a rectangular cross-section and, if necessary, stabilising scotches inserted into the packages, with or without packing.

- ① Stabilising scotches with a maximum thickness of 15 mm may be inserted into the package. They may not be inserted between each tier. The stabilising scotches at the ends of the packages must be placed where end bindings of the package are located.

The stabilising scotches may be inserted every two tiers at most, depending on the thickness of the sawn timber.

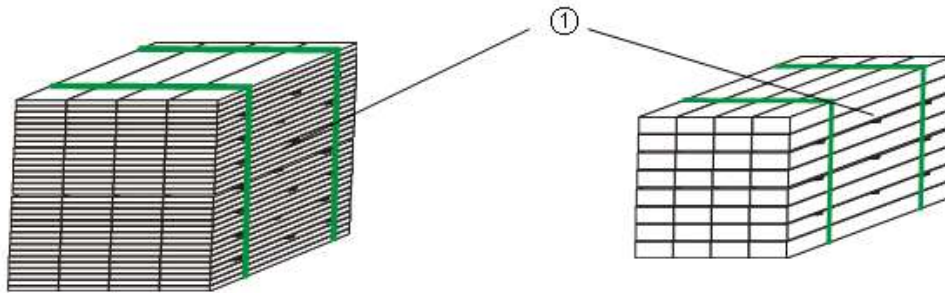

Packages up to 4,5 m long are bound by two bindings at least, with an additional binding every time a new section of 1.5 m is started.

- ② When drying scotches are used inside the packages: three bindings at least and an additional binding every time a new section of 1.5 m is started. The end bindings are placed above or immediately next to the drying scotches.
- ③ The end bindings are distant by at least 30 cm from the ends of the package.

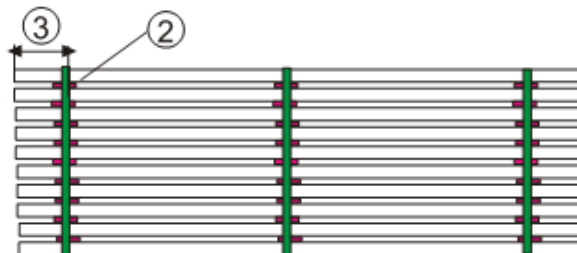

Breaking strength of the package bindings (straight pull): 1000 daN; the attachment point, in case of PET straps, must ensure at least 80% of the breaking strength (straight pull). Minimum pre-tensile force: 300 daN.

Steel wire or PP straps may not be used.

### Wagons

Flat wagons with high collapsible end boards, stanchions and wooden floors, or in-built bolsters, or anti-skid materials, with or without collapsible boards.

Wagons with metallic sliding walls or covers.

Flat wagons with stanchions and wooden floors, or in-built bolsters, or with anti-skid materials, with or without collapsible boards.

Wagons with metallic sliding walls or covers.

<sup>1)</sup> If the packets are not compactly linked, they are to be transported only on flat wagons with metallic sliding walls or covers.



## Securing

Packages of unequal length should be secured on each longitudinal side of the wagon in accordance with numbers ⑧ to ⑮.

The stacks are secured:

- ⑧ - by the collapsible boards<sup>2)</sup> and/or the stanchions<sup>2)</sup> or by the end walls and the sliding walls<sup>2)</sup> / hoods<sup>2)</sup>. Effective height of the collapsible boards or stanchions: 10 cm minimum,
- ⑨ - by at least two indirect fastenings (minimum breaking strength: 4000 daN),
- ⑩ If three supporting scotches / inserts are in the stack, at least three indirect fastenings are required (minimum breaking strength: 4000 daN).

On wagons equipped with an indirect fastening device (minimum breaking strength: 4000 daN) and a covering layer, if the indirect fastenings are too short, the fastening may pass under the covering layer, over the packages of sawn timber,

on condition that:

- the uppermost tier under the covering layer is indirectly fastened and bound together with the covering layer (straps with an in-built tensioning device, minimum breaking strength: 4000 daN).

Number of bindings:

- The number of bindings required is equal to the number of indirect fastenings required by ⑨.

Any packages not secured in accordance with ⑧ must be secured in accordance with ⑭ or ⑮.

- ⑪ Indirect fastenings are placed at least 30 cm from the ends of the stacks and highly tensioned. In case of there being three supporting scotches / inserts, the middle indirect fastening must be placed above or immediately next to the middle supporting scotches / inserts.
- ⑫ If the packages are only secured by two stanchions, they must extend lengthways beyond stanchion centres by at least:



- ⑬ The packages must be secured by an additional indirect fastening (minimum breaking strength<sup>3)</sup>: 4000 daN), except in case of stacks secured by means of at least three indirect fastenings
  - in case of a missing pair of stanchions, **or**
  - if ⑫ is not observed **or**
  - if the distance from neighbouring stanchions is lower than  $\frac{1}{3}$  of the length of the stack measured from the stanchion centres.

Isolated packages in the top tier (except in case of securing in accordance with ⑩) and packages resting next to each other when ⑧ is not observed must always:

- ⑭ - be secured laterally upwards and downwards by means of nailed scotches; the number of nails ( $\varnothing$  approx. 5 mm) on each longitudinal side must be one per 2000 kg of load mass and at least two nails per scotch, **or**
- ⑮ - be bound twice with the underlying tier(s) secured by stanchions; the breaking strength (straight pull), including the attachment, should be 700 daN and the pre-tensile force at least 300 daN.

Metallic wire, steel strips (on open wagons) and PP straps may not be used.

In case of smooth supporting scotches or inserts and/or packing ( $\mu < 0.3$ ), the packages resting on those supporting scotches or inserts should also be secured by anti-skid strips placed under the edges of the packages ⑯ (dimensions: approximately 150 x 80 x min. 3 mm).

## Additional indications

Load of wagons: see information sheet 0.1,

Maximum dimensions of loads: see information sheet 0.2,

Single-use bindings<sup>3)</sup>: see information sheet 0.6,

Indirect fastenings<sup>3)</sup>: see information sheet 0.7,

Friction and coefficients of friction: see information sheet 0.8.

<sup>2)</sup> Including in case of a lateral distance > 10 cm vis-à-vis the walls/hoods, collapsible boards or stanchions without wooden guide-pieces.

<sup>3)</sup> The minimum breaking strength (straight pull) corresponds to double the permitted tensile force (LC); this concerns only synthetic straps, woven straps and load securing straps, as well as lashing steel wire ropes and lashing chains.



## 2.4 Wood in bundles

Single wagons and groups of wagons

Wagons in block trains or combined transport  
Wagons with long-stroke shock absorbers

### Type of goods

Bundles of round wood, slabs or kindling, bound so that no wood can fall out

- Minimum two bindings per bundle (breaking strength at least 700 daN)
- at least four bindings for bundles over 4 m long

### Wagons

Wagons with walls, sides or stanchions

### Method of loading

Bundles should be placed lengthways in the wagon.

- ① - laid closely against one another
- ② - bundles in contact with the walls or stanchions must not extend above them by more than half their diameter
- bundles extending above the walls or stanchions must be dovetailed.
- ③ If the part of the load supported against the stanchions is greater than half the height of the stanchions, opposing removable stanchions should be tied together about half-way up (breaking strength of fastenings at least 1000 daN).

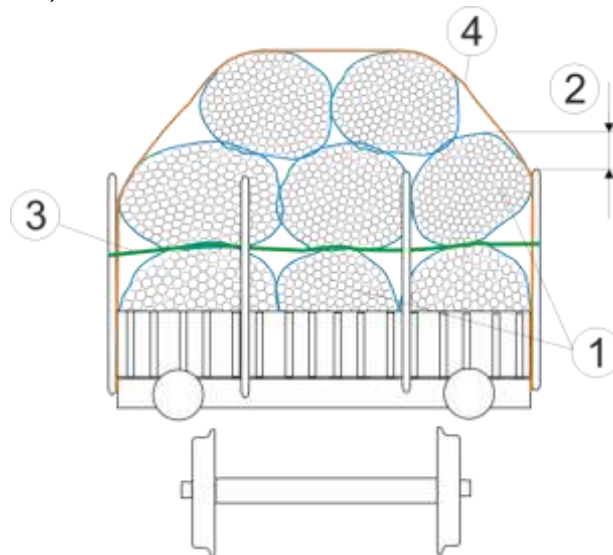

### Securing

When secured with only two stanchions on each side, the bundles must extend lengthways beyond the centre of the stanchions by at least

30 m

20 cm

- ④ Bundles which project above the walls or stanchions by more than half their diameter should be secured with at least two indirect fastenings (breaking strength at least 1000 daN).  
Curved section of load should be max.  $\frac{1}{3}$  of the load width.

### Additional indications

Load of wagons: see information sheet 0.1,  
Maximum dimensions of loads: see information sheet 0.2,  
Single-use bindings<sup>1)</sup>: see information sheet 0.6,  
Indirect fastenings<sup>1)</sup>: see information sheet 0.7,

<sup>1)</sup> The minimum breaking strength (straight pull) corresponds to double the permitted tensile force (LC); this concerns only synthetic straps, woven straps and load securing straps, as well as lashing steel wire ropes and lashing chains.



## 2.5 Wooden sleepers (in packages)

Single wagons and groups of wagons

Wagons in block trains or combined transport  
Wagons with long-stroke shock absorbers

### Type of goods

- ① Wooden sleepers, unimpregnated and in packages
- ② - sleepers of the same dimensions tied into packages with at least two bindings (breaking strength of bindings at least 1000 daN)
- ③
  - distance of bindings from ends of packages at least 30 cm

### Wagons

Wagons with walls, sides or stanchions

### Method of loading

Packages should be placed lengthways

- in one or more tiers, wherever possible spread over the full width of the wagon
- ④ - directly onto the wagon floor **or**
    - on bolsters or softwood timbers
      - of rectangular cross-section, resting on the broader face,
      - of one piece or several overlapping pieces of the same thickness laid side by side. Where this is the case, the number of timbers must not be greater than the number of juxtaposed packages
  - ⑤ Minimum clearances (except on E- and Roos wagons).

30 cm

0 cm

- ⑥ Packages should extend beyond the timbers by at least 50 cm

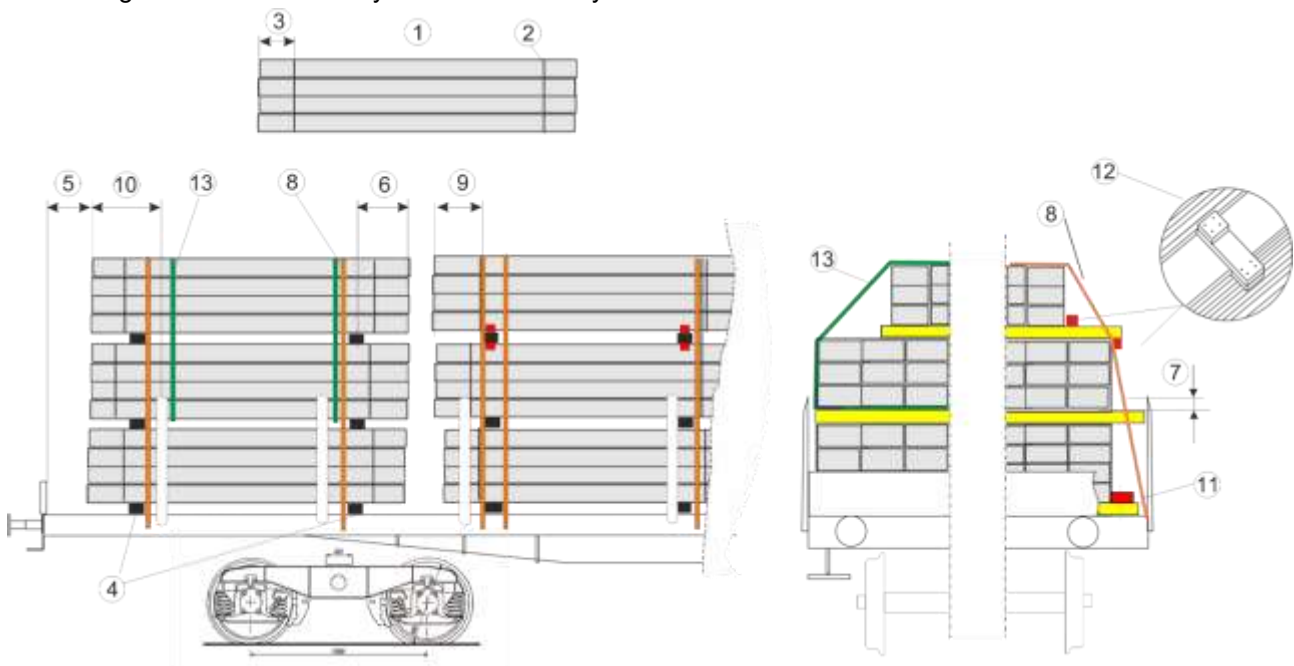

### Securing

Packages should be

- Secured by the walls, sides or stanchions
- ⑦
    - with effective height at least 10 cm
  - ⑧ - Secured by at least two indirect fastenings (breaking strength at least 1000 daN) **or**
    - One strap with a tensioning device in the centre of the package and breaking strength at least 4000 daN

## 2.5

⑨ Fastenings should be made approx. 50 cm from the ends of the stacks

When secured by only two stanchions on each side

⑩ - The packages should extend lengthways beyond the stanchion centre by at least

30 cm

20 cm

- In the absence of a stanchion pair or if ⑩ is not complied with, secured using an additional indirect fastening, breaking strength at least 1000 daN (e.g. straps, bands)

⑪ - laterally secured using scotches nailed in place, if the distance between the stacks and the side stanchions is more than 10 cm; total number of nails of 5 mm in diameter along each side: one nail / 2000 kg load weight, at least two nails per scotch

Individual packages in the upper tier and adjacent packages if ⑦ is not complied with should be

⑫ - secured laterally using scotches nailed on top and bottom; total number of nails of 5 mm in diameter along each side: one nail/2000 kg of load (at least two nails per scotch) **or**

⑬ - bound twice (breaking strength of fastening at least 1000 daN)

### Additional indications

Load of wagons: see information sheet 0.1,

Maximum dimensions of loads: see information sheet 0.2,

Single-use bindings<sup>1)</sup>: see information sheet 0.6,

Indirect fastenings<sup>1)</sup>: see information sheet 0.7.

---

<sup>1)</sup> The minimum breaking strength (straight pull) corresponds to double the permitted tensile force (LC); this concerns only synthetic straps, woven straps and load securing straps, as well as lashing steel wire ropes and lashing chains.

## 2.6 Wooden sleepers, impregnated (in packages)

Single wagons and groups of wagons

Wagons in block trains or combined transport  
Wagons with long-stroke shock absorbers

### Type of goods

- ① Wooden sleepers treated with creosote and in maximum package size: five tiers of four sleepers
- ② - each sleepers of the same dimensions should be tied into packages with at least two bindings (breaking strength of bindings at least 1000 daN)
- ③
  - distance from ends of packages at least 30 cm

### Wagons

Wagons with walls, sides and stanchions

### Method of loading

Packages should be placed lengthways

- in one or more tiers, wherever possible spread over the full width of the wagon
- ④ - directly onto the wagon floor, on bolsters or softwood timbers
    - of rectangular cross-section, resting on the broader face,
    - of one piece and spanning the full width of the wagon
  - ⑤ Minimum clearance (except on E- and Roos wagons)
 

50 cm
30 cm
  - ⑥ Packages should be loaded to a maximum of two tiers.
  - ⑦ Packages should extend beyond the timbers by at least 50 cm.

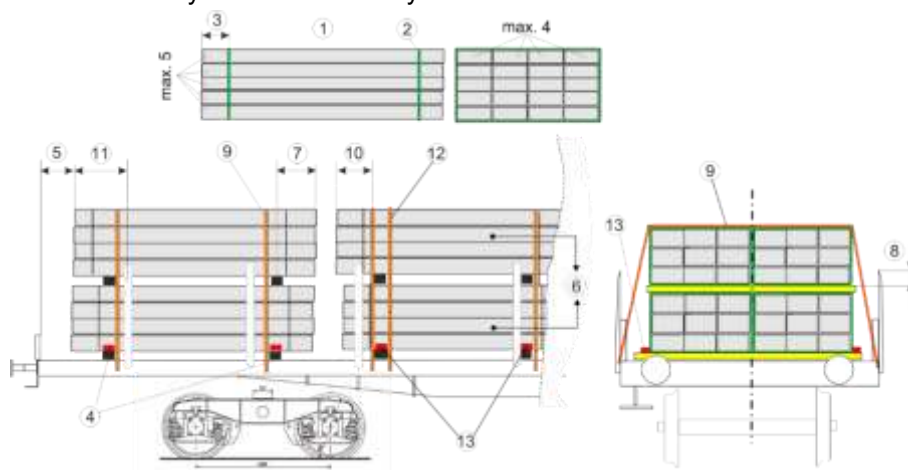

### Securing

Stacks should be

- secured by the walls, sides or stanchions
- ⑧ - effective height of the walls, sides or stanchions at least 10 cm
  - ⑨ - secured by at least two fastenings (minimum breaking strength 4000 daN)
  - ⑩ Fastenings should be made about 50 cm from the end of stacks.

When secured by only two stanchions

- ⑪ - the stacks should extend lengthways beyond the stanchion centres by at least
 

50 cm
30 cm
- ⑫ - in the absence of a pair of stanchions or if ⑪ is not complied with, secured by an extra indirect fastening (with breaking strength at least 4000 daN)
- ⑬ - laterally secured using scotches nailed in place, if the distance between the stacks and the side stanchions is greater than 10 cm; total number of nails of 5 mm in diameter down each side: one nail/1500 kg load weight, at least two nails per scotch.

### Additional indications

Load of wagons: see information sheet 0.1,

Maximum dimensions of loads: see information sheet 0.2,

Single-use bindings<sup>1)</sup>: see information sheet 0.6,Indirect fastenings<sup>1)</sup>: see information sheet 0.7.

<sup>1)</sup> The minimum breaking strength (straight pull) corresponds to double the permitted tensile force (LC); this concerns only synthetic straps, woven straps and load securing straps.



## 2.7 Wooden sleepers (untied)

Single wagons and groups of wagons

Wagons in block trains or combined transport  
Wagons with long-stroke shock absorbers

### Type of goods

Wooden sleepers, not treated with creosote and untied

### Wagons

Wagons with walls, sides or stanchions

### Method of loading

Wooden sleepers should be loaded over the full width of the wagon in one or more tiers

- lengthways or crossways in the wagons with walls or sides, with no additional securing
- lengthways only in wagons with stanchions

① Minimum clearances (except for loads secured lengthways by the end walls):

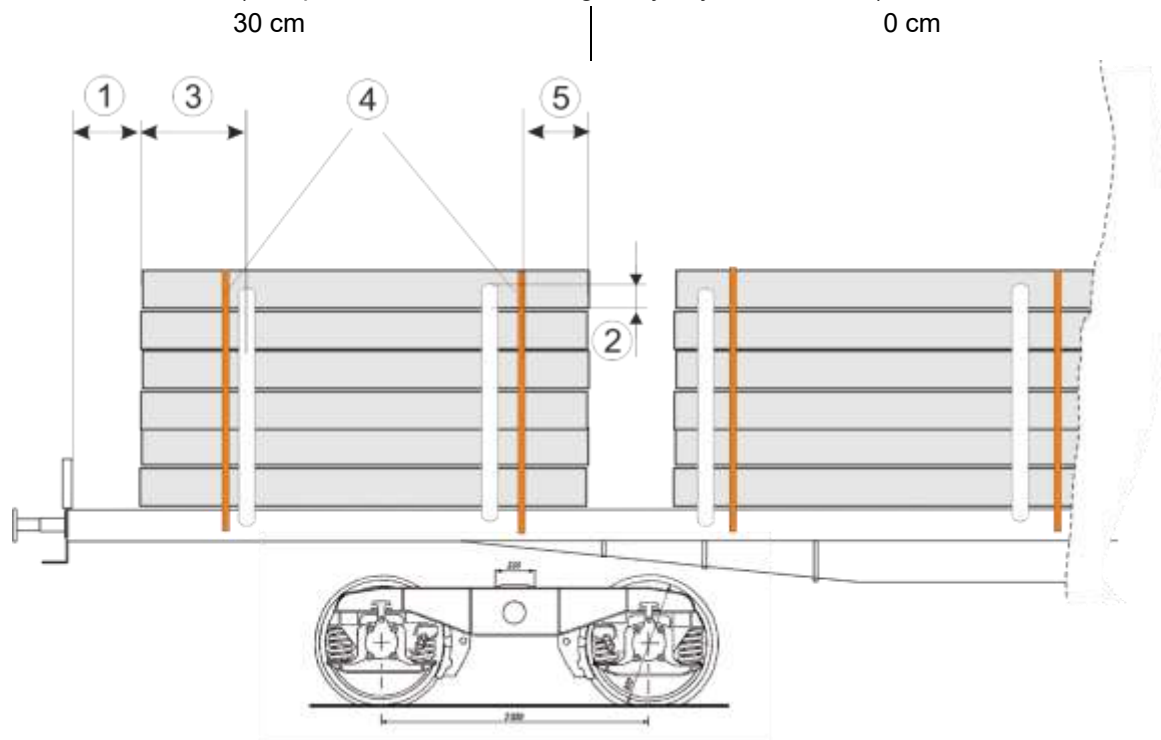

### Securing

② Upper tier secured by the walls, sides or stanchions (effective height at least 10 cm).

When secured by only two stanchions on each side

③ - the stacks must extend lengthways beyond the stanchion centres by at least

30 cm

20 cm

④ On wagons with stanchions, stacks should be doubly fastened.

Breaking strength of bindings at least 4000 daN (with tensioning device).

⑤ Distance between the bindings and the ends of the stacks approx. 50 cm.

### Additional indications

Load distribution: see information sheet 0.1

Single-use fastenings<sup>1)</sup>: see information sheet 0.6,

Indirect fastenings<sup>1)</sup>: see information sheet 0.7,

<sup>1)</sup> The minimum breaking strength (straight pull) corresponds to double the permitted tensile force (LC); this concerns only synthetic straps, woven straps and load securing straps, as well as lashing steel wire ropes and lashing chains.



## 2.8 Wood chippings

Single wagons and groups of wagons

Wagons in block trains or combined transport  
Wagons with long-stroke shock absorbers

### Type of goods

Wood chips of various types of wood.

### Wagons

Wagons with high sides

### Method of loading

Wood chippings should be

- evenly spread over the loading surface,
- ① - loaded no higher than 10 cm below the top of the sides (including at the wagon centre) or
- ② - loaded no higher than the top of the sides (including at the wagon centre) or
- ③ - in a cone formation up to 50 cm high. The height between the wood chippings and the edge of the sides must not be less than roughly 15 cm.

### Securing

- ④ When loading methods ② or ③ are used, the full surface of the chippings should be covered.
- ⑤ Covering material should be fixed at approx. 2 m intervals
  - with non-metallic fastenings (breaking strength of fastenings approx. 50 daN)
- ⑥ • tied to the netting **or**
- ⑦ • bound over the netting **or**
- ⑧ • hooked tautly onto the wagon hooks (hooks present on Eanos wagons).

When synthetic netting is used as covering material:

- Mesh size approx. 30 mm,
- Breaking strength<sup>1)</sup> at least 39 daN lengthways and at least 48 daN crossways

On Tms wagons the load is secured by closing and locking the roof.

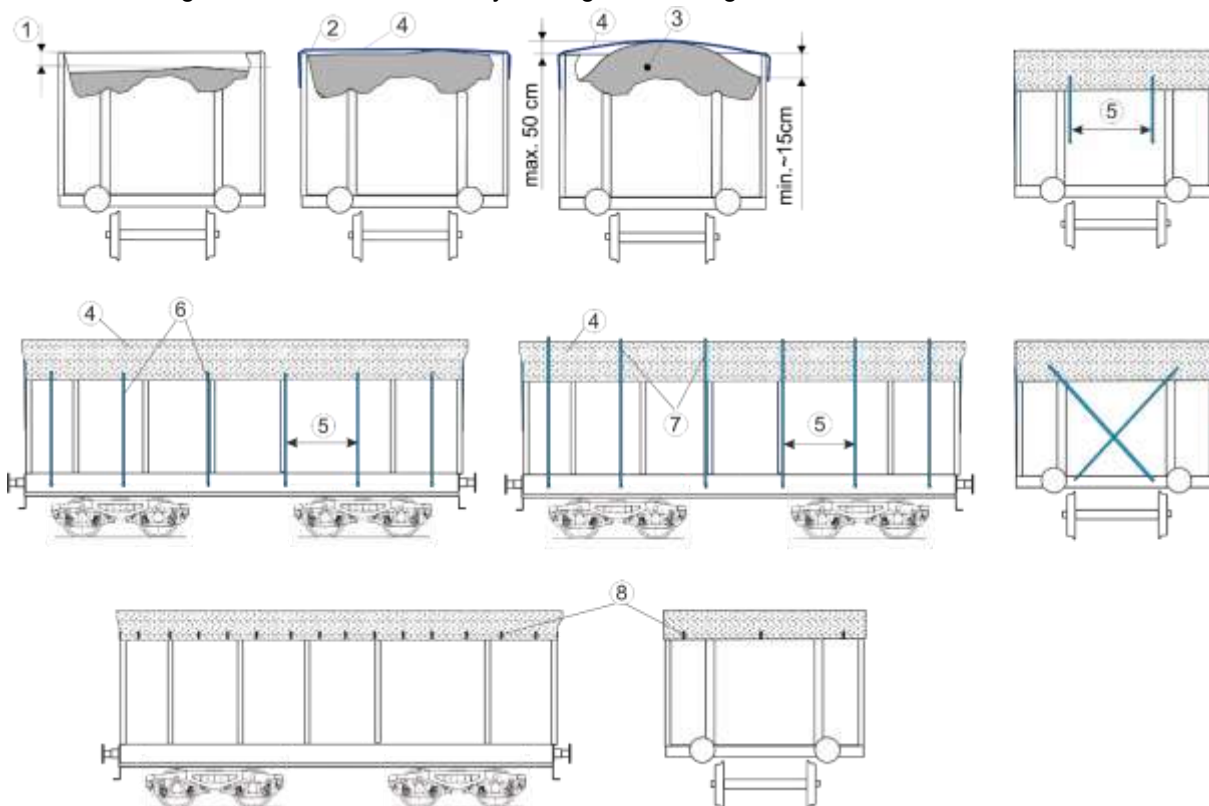

### Additional indication

Wood chippings should not be compressed.

<sup>1)</sup> Strength test to be carried out on a sample 10 cm wide incorporating 3 threads.



## 2.9 Plywood slabs, hardboard

Single wagons and groups of wagons

Wagons in block trains or combined transport  
Wagons with long-stroke shock absorbers

### Type of goods

Plywood and hardboard slabs coated or uncoated, bound into packages.

- ① Height of packages
  - for smooth-coated slabs approx. 60 cm,
  - for uncoated slabs, approx. 100 cm.
- ② Bindings with edge protection at intervals of approx. one metre, at least two bindings per package length (breaking strength at least 1400 daN).

### Wagons

Wagons with wooden floor and if possible locking partition walls

### Method of loading

- ③ Packages should be laid on wooden timbers in one or several tiers.
- ④ Timbers and bolsters should be made of soft wood:
  - of rectangular cross-section and resting on the broader face,
  - of one piece or a maximum of three overlapping pieces covering the full width of the load unit.
- ⑤ Stack heights should not exceed 1.8 m for smooth-coated slabs.
- ⑥ Stacks should be bound together with at least two bindings with edge protection (breaking strength of bindings at least 2200 daN).

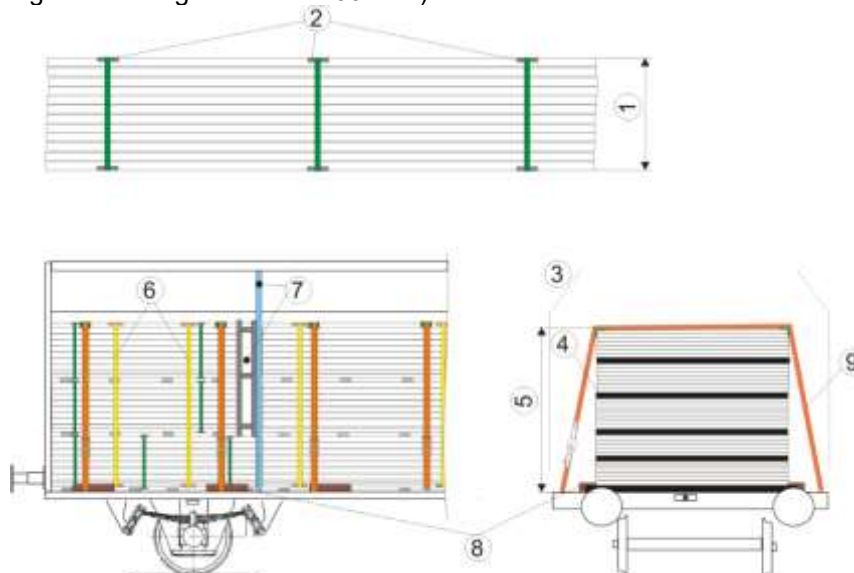

### Securing

- lengthways in the wagon:
- ⑦
    - by locking partition walls **or**
    - by filling in the intermediate space (e.g. with wooden cross-bracings),
  - crossways in the wagon
  - ⑧
    - by timbers nailed in place, at least two on each side of every stack. Timbers should be at least 50 mm thick with an effective height of at least 30 mm; number of nails of 5 mm diameter in the timbers on each side: one nail/1500 kg of load **or**
  - ⑨
    - by at least two indirect fastenings per stack with tensioning devices and edge protection (breaking strength of bindings at least 4000 daN)

### Additional indications

Load of wagons: see information sheet 0.1,  
Single-use bindings<sup>1)</sup>: see information sheet 0.6,  
Indirect fastenings<sup>1)</sup>: see information sheet 0.7

<sup>1)</sup> The minimum breaking strength (straight pull) corresponds to double the permitted tensile force (LC); this concerns only synthetic straps, woven-fabric straps and load securing straps, as well as lashing steel wire ropes and lashing chains.



## 2.10 Glue-laminated timber (GL) or solid construction timber (SCT) in packages

Single wagons and groups of wagons

Wagons in block trains or combined transport  
Wagons with long-stroke shock absorbers

### Type of goods

Glue-laminated timber (GL) or solid construction timber (SCT) bound into compact packages with a rectangular cross-section.

Packages held together by:

- ① - coextruded blown film (biaxial orientation), consisting of at least three layers with one adhesive and one smooth layer. Films manufactured using metallocenes without addition of polyisobutenes (PIB), technical specifications in accordance with table 1.
- ② - Packages are wrapped in a coextruded blown film, pre-stressing min. 150 %, films' overlap ② min. 50 mm
- or
- ③ - at least two package fastenings for package lengths up to 6 m, at least one additional fastening per additional 1.5 m section or partial section. Breaking strength<sup>1)</sup> of the package fastening 1000 daN in tangent traction, where the fastening point in case of use of PET straps must ensure at least 80 % of the breaking strength for tangent traction. Minimum pre-stressed force 300 daN.

Steel wire and polypropylene (PP) straps may not be used.

Films shall be positioned in such a way as to exclude their breaking loose as a result of wind or dynamic forces exerted in transport.

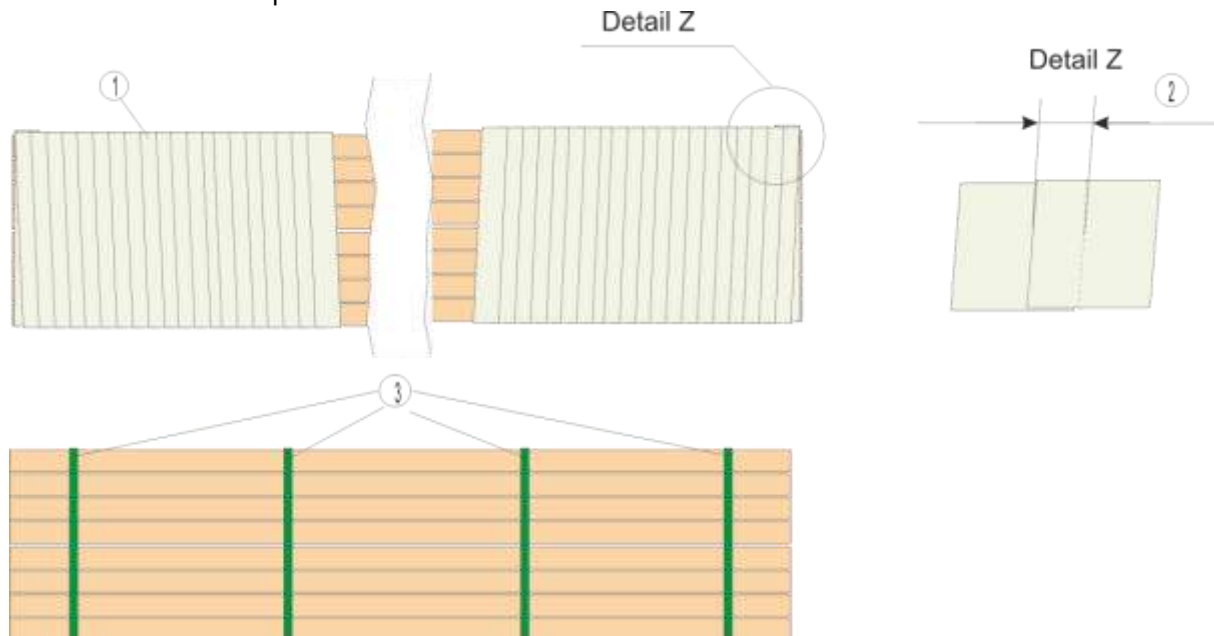

### Wagons

#### a) Packages wrapped in films

- Flat wagons with stanchions and wooden floors or integrated bolsters or friction materials, with or without sides, with or without mechanically sheeted hood
- Wagons with sliding walls or metal roofs

#### b) Packages not wrapped in films

Flat wagons with high end walls, stanchions and wooden floors  
Wagons with sliding walls or metal roofs

Flat wagons with stanchions and wooden floors, with or without sides, with or without mechanically sheeted hoods

<sup>1)</sup> Minimum breaking strength in tangent traction is equivalent to twice the permissible traction strength (LC) and only applies to synthetic straps, woven straps and load-securing straps, as well as lashing steel wire ropes and lashing chains.

## 2.10

### Method of loading

Packages should be loaded side by side and one behind another. Packages with the same dimensions should where possible be arranged side by side and one on top of another. Height differences are to be evened out, or, where appropriate, individual packages may be placed in the middle of the top tier on underlying packages of equal height. Packages of unequal length should be loaded as compactly as possible.

In case of packages not wrapped in films stacks must be tightly loaded one on top of the other without projecting lengthways beyond the end walls.

#### Loading

- ④ - Packages should rest on bolsters, timbers or intermediate timbers of one piece and spanning the full width of the wagon, even when using bound-in timbers.
- ⑤ A maximum of two layers may be loaded on top of each other without intermediate timbers when a maximum of two packages of equal cross-section are loaded side by side and one on top of the other and lying on their broader face.
- ⑥ In order to even out height differences it is possible to dispense with end-to-end intermediate timbers above the upper layer, which itself is positioned on end-to-end intermediate timbers, if the packages loaded onto this layer are of approximately the same width.
- ⑦ - Timbers/intermediate timbers - of rectangular cross-section and lying on their broader face<sup>2)</sup> - may be made up of several pieces of the same thickness, overlapping at the sides; where this is the case, however, the number of pieces of wood must be no greater than the number of packages lying side by side  
- Timbers/intermediate timbers made up of several superimposed layers must be properly bound together and span the whole width of the wagon at once.
- ⑧ Timbers/intermediate timbers in the stacks should, where possible, be placed one on top of the other and positioned around 50 cm from the package ends.

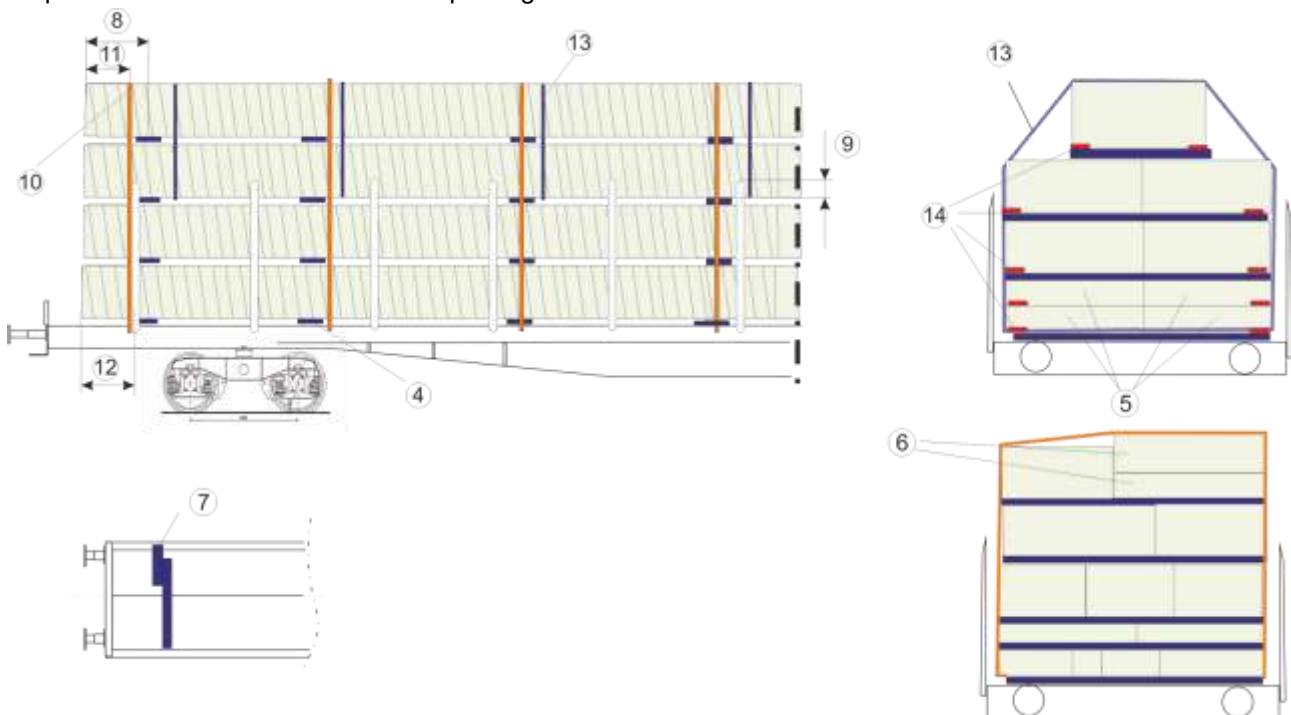

<sup>2)</sup> Timbers of square cross-section (at least 6x6 cm) are accepted provided all the edges of the wood used are sharp, except in case of bound-in timbers

## Securing

Packages of unequal length should be secured down each longitudinal side of the wagon as shown in ⑦ to ⑫.

Stacks should be

- secured by the sides<sup>3)</sup> and/or stanchions<sup>3)</sup> or by the end walls and the sliding walls<sup>3)</sup>/hoods<sup>3)</sup>

⑨ Effective height of the sides or stanchions must be at least 10 cm.

⑩ - secured by indirect fastenings

- with one tensioning strap per 3 m section/partial section (breaking strength min. 4000 daN, in tangent traction), with a minimum of two straps **or**
- with one securing strap per 1.5 m section/partial section (breaking strength min. 1000 daN, in tangent traction), with a minimum of two straps

⑪ Indirect fastenings should be made at least 30 cm from the end of stacks and pulled tight

⑫ When secured by only two stanchions the packages should extend lengthways beyond the stanchion centres by at least

30 cm



20 cm

- where stacks are secured by one pair of stanchions only, or if the coverage of the stanchions is not complied with, secured by an extra indirect fastening.

For individual packages on the upper tier in all cases, and adjacent packages on the upper tier when ⑨ is not complied with:

⑬ - bound with the tier(s) arranged below and secured with the stanchions, with one fastening per 3 m section/partial section and at least two fastenings per stack. Breaking strength of the fastening including the fastening point: 700 daN in tangent traction, minimum pre-stressed force: 300 daN.

Metal wires, steel strips (on open wagons) and polypropylene (PP) straps may not be used.

⑭ In case of use of smooth timbers or intermediate timbers and/or packaging ( $\mu < 0.3$ ) packages which are placed on such timbers or intermediate timbers shall be additionally secured by friction inserts placed at the ends of the packages (approx. dimensions: 150 x 80 x min. 3mm,  $\mu = 0.7$ )

### Additional indications

Load of wagons: see information sheet 0.1,

Maximum dimensions of loads: see information sheet 0.2,

Single-use bindings: see information sheet 0.6,

Indirect fastenings: see information sheet 0.7,

Partition wall loadings: see loading method 100.1.

<sup>3)</sup> Also, without guide-pieces if more than 10 cm from the walls/hoods, sides or stanchions

## 2.10

TABLE 1

Test method	Specification	Unit of measurement	Value
DIN EN ISO 527 Lengthways Crossways	<b>Breaking stress</b>	MPa	> 45 > 35
DIN EN ISO 527 Lengthways Crossways	<b>Breaking elongation</b>	%	> 700 > 850
DIN EN ISO 527 Lengthways Crossways	<b>Yield stress</b>	MPa	> 11,0 > 11,0
DIN EN ISO 8295	<b>Friction coefficient</b>	COF	0,35-0,40
ASTM D5458-1995	<b>Adhesion</b>	gr/inch	> 200
ASTM D 1709 Method A	<b>Dart-Drop test</b>	gr	> 140
DIN 53128 Lengthways Crossways	<b>Elmendorf</b>	gr	> 200 > 700

## **Chapter 3: Agriculture**



### 3.1 Peat and similar substances in compressed bales

Single wagons and groups of wagons

Wagons in block trains or combined transport  
Wagons with long-stroke shock absorbers

#### Type of goods

Peat and similar substances in compressed bales

#### Wagons

Wagons with walls or sides and stanchions

#### Method of loading

Bales should be loaded in tiers of similar height, packed as tightly as possible against one another and stacked in criss-cross formation.

The outer bales of each tier lie directly against the walls or stanchions.

The last tier should consist of a single row of bales lying crossways over all the bales of the tier beneath, so that the indirect fastenings act on all the bales.

- ① The load should be covered with sheets which are tucked between the load and the stanchions at the wagon ends.

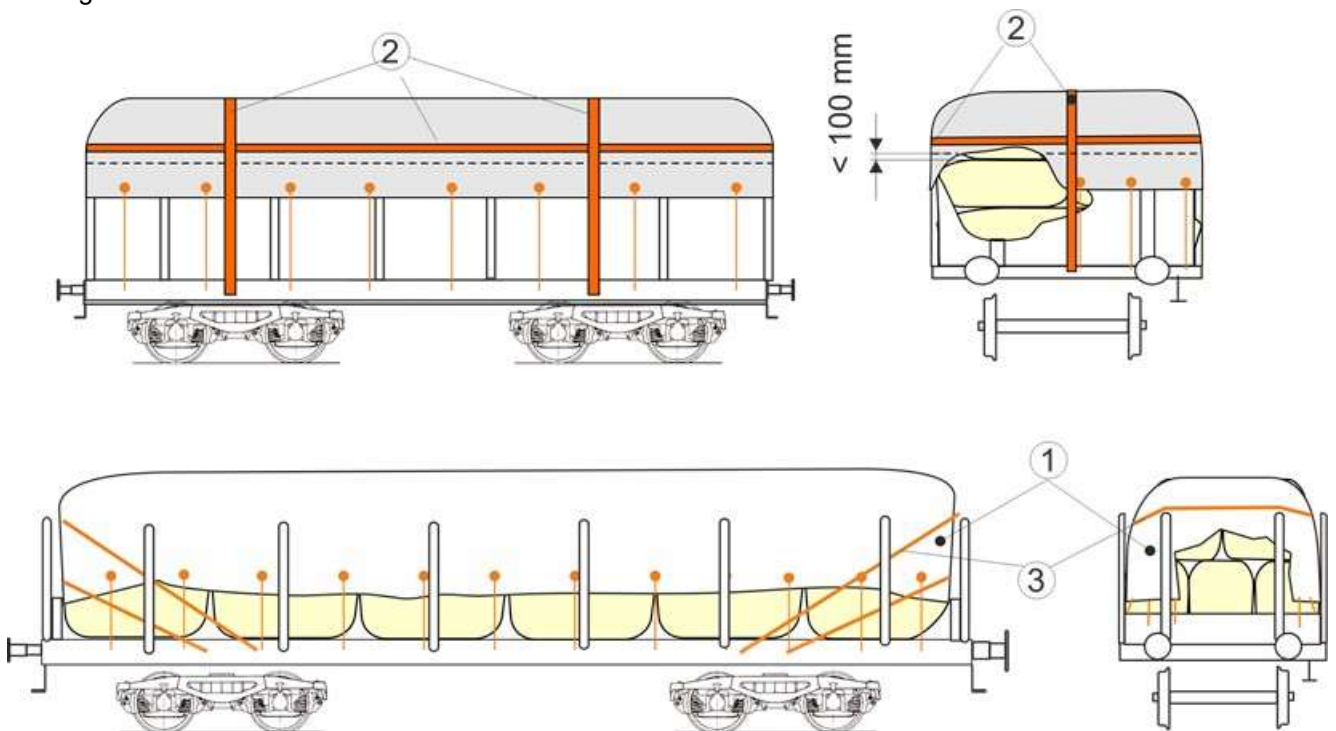

#### Securing

- ② If the tiers are not supported to at least 10 cm of their height by the walls or sides, the load should be indirectly fastened to the wagon over the top of the sheeting at least once lengthways and twice across with non-metallic bindings (breaking strength at least 1000 daN).
- ③ Loads on flat wagons  
the wagon ends by oblique fastenings.

#### Additional indications

Load of wagons: see information sheet 0.1

Maximum dimensions of loads: see information sheet 0.2

Covering of loads: see information sheet 0.3

Single-use bindings<sup>1)</sup>: see information sheet 0.6,

Indirect fastenings<sup>1)</sup>: see information sheet 0.7.

<sup>1)</sup> The minimum breaking strength (straight pull) corresponds to double the permitted tensile force (LC); this concerns only synthetic straps, woven straps and load securing straps, as well as lashing steel wire ropes and lashing chains.



## Chapter 4: Paper



## 4.1.1 Rolls of paper loaded on the roll (“eye-to-side”)

Single wagons and groups of wagons

Wagons in block trains or combined transport  
Wagons with long-stroke shock absorbers

### Type of goods

Rolls of paper

### Wagons

Wagons with wooden floor and sliding walls or mechanically-operated curtain sides and fixed end walls (H..., Li..., Rils, Si...)

### Method of loading

Rolls should be loaded

- ① - in one or more groups, in one or more rows, covering as much of the floor surface as possible
- ② - in a maximum of two dovetailed tiers with rolls of greatest diameter in the lower tier.

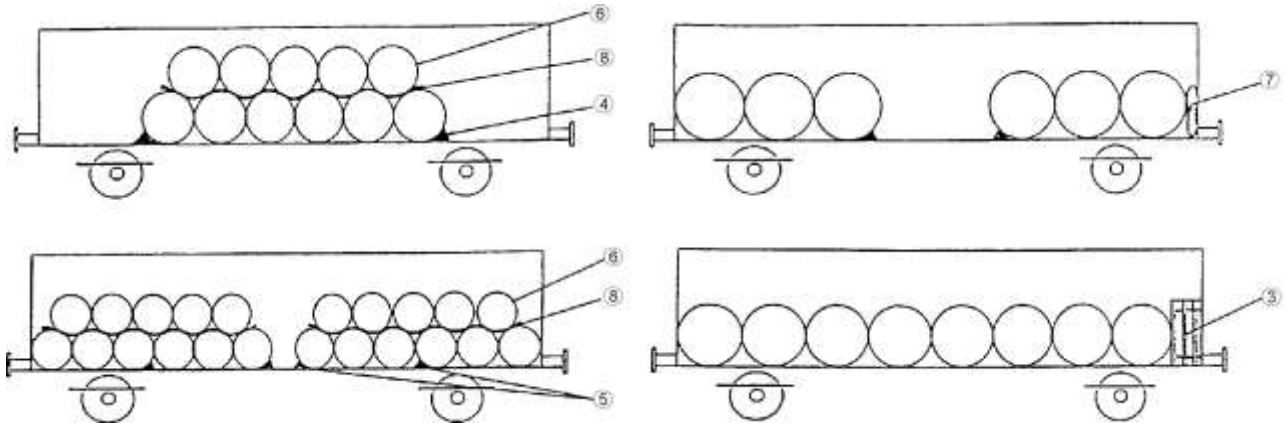

### Securing

Lengthways in the wagon

- the rolls in the lower tier are secured
- ③ • by the wagon ends (gaps to be filled in as appropriate) **or alternately**
  - ④ • by scotching the end rolls with 2 spiked steel scotches for each roll **or else**
  - ⑤ • using wooden scotches placed at one end or both ends **and** every three to four rolls
    - two scotches at each point when the roll is no wider than 1,5 m and four scotches at each point when the roll is more than 1,5 m wide
    - scotch height: 15 cm for roll diameters up to 80 cm, 20 cm for diameter > 80 cm
    - scotch width: approx. 20 cm, scotch angle approx. 35°
    - total number of nails (diameter 5 mm) in each running direction
 

one nail/1500 kg	one nail/3000 kg
------------------	------------------
- of load weight, with at least two nails per scotch
- the rolls in the upper tier are secured
- ⑥ • by the dovetail formation (the diameter of rolls in the upper tier must not be greater than that of the rolls in the lower tier)
  - ⑦ Where the rolls are liable to be damaged insert flexible material as shown at the wagon ends
  - ⑧ Crosswise in the wagon, the rolls in the upper tier are secured by two strips made from friction-enhancing inserts (e.g., strips of rubber or granulated composite rubber or treated cotton webbing) placed approx. 15 cm from the ends of rolls.

### Additional indications

Load of wagons: see information sheet 0.1

Friction and coefficients of friction: see information sheet 0.8.



## 4.1.2 Rolls of paper loaded “gunshot” (eye-to-end)

Single wagons and groups of wagons

Wagons in block trains or combined transport  
Wagons with long-stroke shock absorbers

### Type of goods

Rolls of paper

### Wagons

Wagons with sliding walls, mechanically-operated curtain sides, opening roof, sides, stanchions or fixed end walls

### Method of loading

Rolls should be loaded

- ① - in one or more groups, covering as much of the floor surface as possible,
- ② - to a maximum of two dovetailed tiers with rolls of greatest diameter in the lower tier.
- ③ - rolls should not rest against the doors, sliding walls, sliding curtain sides, sides or stanchions.

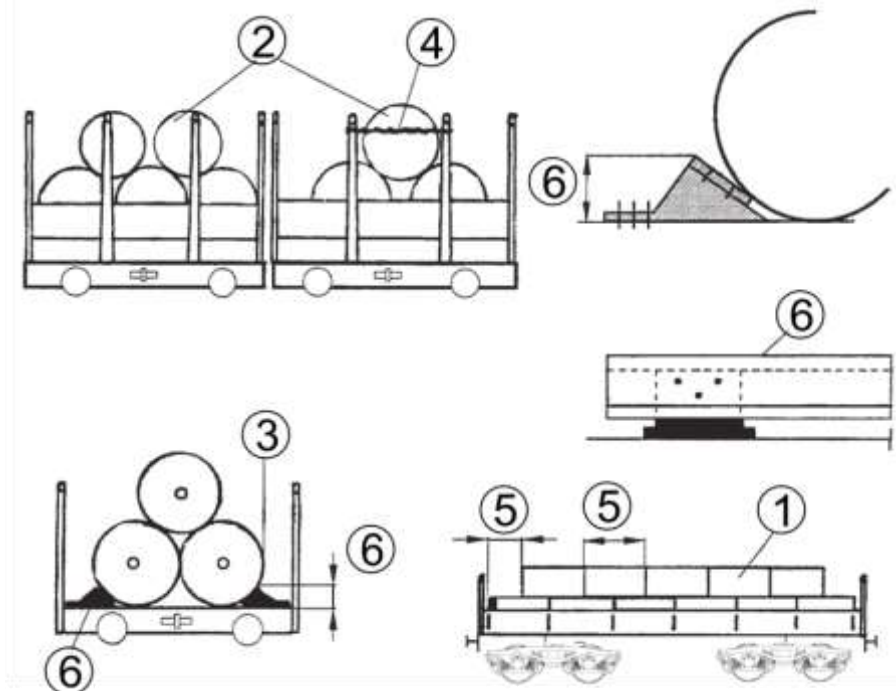

### Securing

Lengthwise, the rolls in the lower tier are secured

- by the end boards or walls.

When loaded in dovetailed formation, the end rolls of the second tier are secured by the wagon ends or by the end stanchions

- ④ - if necessary tied together,  
or else
- ⑤ - inset by one half-length of a roll
- ⑥ Crosswise in the wagon, at least two scotches should be applied to each outer roll of the bottom tier; the scotches should be linked by a board with rounded edges
  - scotch height  $\frac{1}{12}$  of the roll diameter, but at least 12 cm,
  - scotch width approx. 20 cm, with an angle of approx. 35°,
  - total number of nails (5 mm in diameter) in each running direction: one nail/1500 kg load weight, minimum two nails per scotch.

For rolls laid in a group one behind another or one on top of another, take the total weight of the group.

### Additional indication

Load of wagons: see information sheet 0.1.



### 4.1.3 Rolls of paper loaded upright (eye-to-sky)

Single wagons and groups of wagons

Wagons in block trains or combined transport  
Wagons with long-stroke shock absorbers

#### Type of goods

Rolls of paper

#### Wagons

Wagons with sliding walls and fixed end walls

#### Method of loading

- ① Rolls should be loaded upright in one or more tiers. They should if possible, cover the whole loading surface.

When loaded in several tiers, rolls should be placed exactly one on top of another, with the underlying tier covering the entire loading surface.

- ② - When loaded without intermediate spacing, the diameter of the rolls must be at least  $\frac{5}{10}$  of their height.

- When loaded with intermediate spacing (spacing approximately in the middle of the wagon,

 $\frac{7}{10}$  $\frac{6}{10}$ 

of their height.

- Rolls shall be arranged in the wagon:

- ③ • in a single line, one behind the other (roll axis placed along the longitudinal wagon axis),
- ④ • in two lines, one behind the other (symmetrical vis-à-vis the longitudinal wagon axis)
- ⑤ • in two staggered lines, with the rolls next to each other; any transverse offset  $x$  relative to the roll diameter to be reduced to a minimum, while respecting the transverse distribution,
- ⑥ • in several staggered lines, with the rolls next to each other (symmetrical vis-à-vis the longitudinal wagon axis)

- upright and in contact with the end walls, with space left in the middle of the wagon

- ⑦ - Clearance with the sloping part of the roof at least 10 cm.

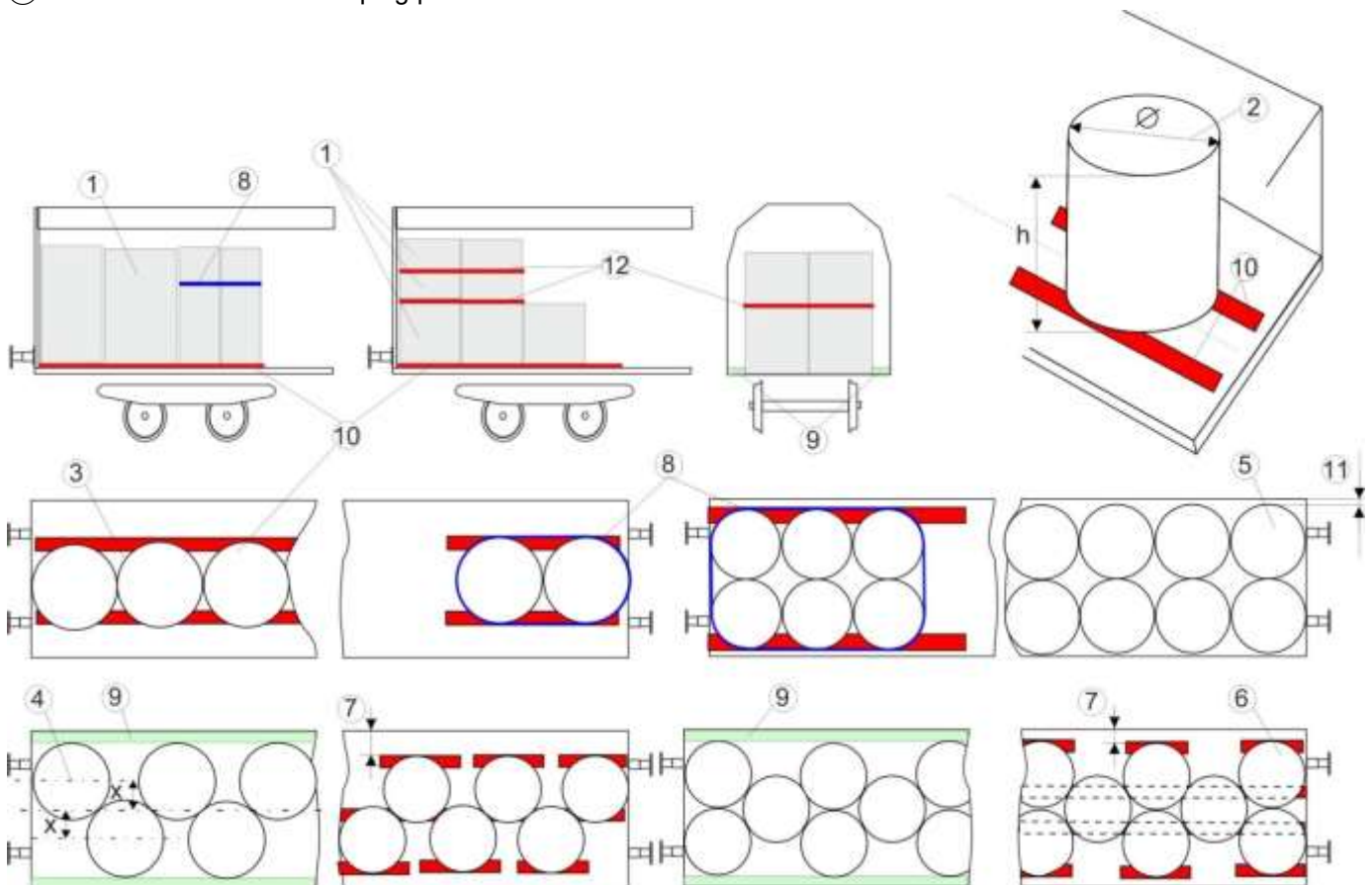

### 4.1.3

#### Securing

lengthways in the wagon:

by the end walls; when loaded with intermediate spacing of more than

50 cm in the middle of the wagon, rolls whose diameter is less than

$\frac{7}{10}$



$\frac{6}{10}$

- ⑧ of their height should be bound together at least at the centre of gravity (breaking strength of bindings at least 1000 daN) and prevented from moving.

crossways in the wagon:

- ⑨ - by guide-rails<sup>1)</sup> that are an integral part of the wagon or are fixed, for example, by the holes in perforated guide-pieces **or**
- by nailed wooden guide-pieces approx. 5 cm high. Number of nails per side: one nail/2000 kg of load mass with at least two nails per guide-piece **or**
  - by cradles resting against the sliding walls (corrugated cardboard, several layers thick, wooden laths) to fill up the lateral clearance in the wagon **or**
- ⑩ - using friction-enhancing inserts, two parallel strips laid lengthways under each roll, with a minimum width of 15 cm in case of rolls with a maximum thickness of 5 mm; the friction coefficient, resistance to deformation and average resistance to dirt shall be guaranteed by the manufacturer, **or**
- ⑪ - by sliding walls: if loaded as shown in ④, loading without friction-enhancing inserts is possible providing the lateral clearance to the sliding wall is  $\leq 10$  cm and the height of the paper rolls is no greater than the vertical part of the sliding wall.
- ⑫ If the rolls are stacked, friction inserts shall be placed between each tier.

#### Additional indications

Load of wagons: see information sheet 0.1

Single-use bindings<sup>2)</sup>: see information sheet 0.6,

Friction and coefficients of friction: see information sheet 0.8.

<sup>1)</sup> For example, profiled tubes of height 5 cm; the upper edge facing the goods should be rounded off to avoid causing damage

<sup>2)</sup> The minimum breaking strength (straight pull) corresponds to double the permitted tensile force (LC); this concerns only synthetic straps, woven straps and load securing straps, as well as lashing steel wire ropes and lashing chains.

## 4.1.4 Rolls of paper and wood pulp loaded upright ("eye-to-sky")

Single wagons and groups of wagons

Wagons in block trains or combined transport  
Wagons with long-stroke absorbers

### Type of goods

Rolls of paper and wood

### Wagons

Bogie wagons and permanently-coupled wagon units with strengthened sliding walls and fixed end walls, marked with the code letters "ii" or conforming to loading method 100.2

### Method of loading

Rolls should be loaded in unbroken formation, packed tightly against one another, in one or two tiers, with the first rolls against the end walls and using as much of the floor area as possible.

- ① When loaded in several tiers, rolls should be placed exactly one on top of another, with the underlying tier covering the entire loading surface.
- ② Diameter of the rolls
  - when loaded without intermediate spacing, at least  $\frac{5}{10}$  of their height
  - when loaded with intermediate spacing (spacing approximately in the middle of the wagon,  $\frac{7}{10}$  of their height |  $\frac{6}{10}$  of their height)
- ③ Rolls shall be arranged in the wagon:
  - in a single line, one behind the other (roll axis placed along the longitudinal wagon axis),
  - in two lines, one behind the other (symmetrical vis-à-vis the longitudinal wagon axis);
  - in two staggered lines, with the rolls next to each other; any transverse offset  $x$  relative to the roll diameter to be reduced to a minimum (symmetrical vis-à-vis the longitudinal wagon axis/ diameter of the rolls), while respecting the transverse distribution,
  - in several staggered lines, with the rolls next to each other (symmetrical vis-à-vis the longitudinal wagon axis);
- upright and in contact with the end walls, with space left in the middle of the wagon
- ⑦ clearance with the sloping part of the roof at least 10 cm.

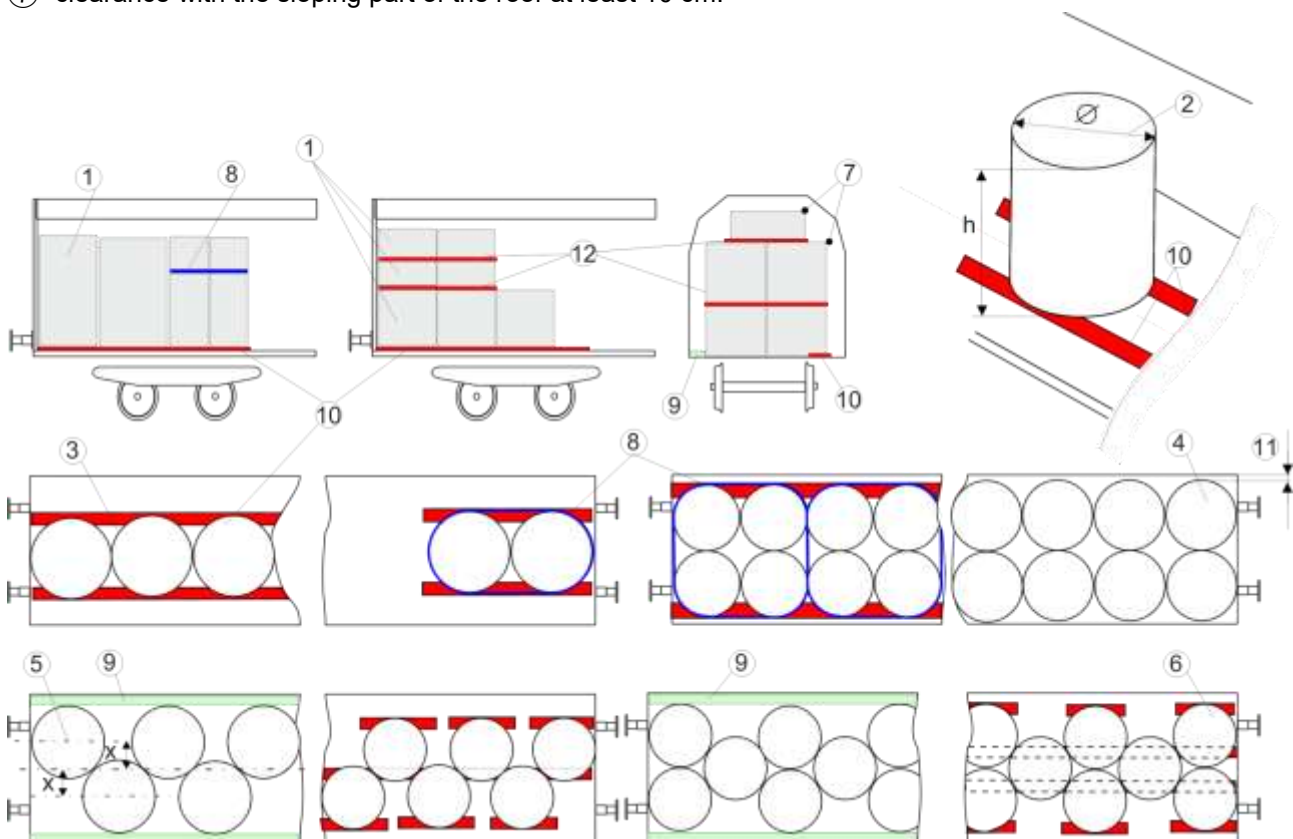

#### 4.1.4

#### Securing

lengthways in the wagon:

by the end walls, if the loading space in the middle of the wagon more than 50 cm, rolls whose diameter is less than

$\frac{7}{10}$



$\frac{6}{10}$

- ⑧ of their height should be bound together at least at the centre of gravity (min. breaking strength of straps: 1000 daN) and prevented from moving.

crossways in the wagon by:

- ⑨ - guide-rails<sup>1)</sup> that are an integral part of the wagon or are fixed, for example, by the holes in perforated guide-pieces **or**
- nailed wooden guide-pieces approx. 5 cm high. Number of nails per side: one nail/2000 kg of load mass with at least two nails per guide-piece **or**
  - cradles resting against the sliding walls (corrugated cardboard several layers thick, wooden laths) to fill up the lateral clearance in the wagon **or**
- ⑩ - using friction-enhancing inserts, two parallel strips laid lengthways under each roll, with a minimum width of 15 cm in case of rolls with a maximum thickness of 5 mm; the friction coefficient, resistance to deformation and average resistance to dirt shall be guaranteed by the manufacturer, **or**
- ⑪ - sliding walls: loading without friction-enhancing inserts is possible providing the lateral clearance to the sliding wall is  $\leq 10$  cm and the height of the paper rolls is no greater than the vertical part of the sliding wall.
- ⑫ If the rolls are stacked centrally friction-enhancing strips/packageings should be placed between each tier.
- If the rolls are not stacked centrally friction-enhancing strips/packageings between tiers (at least two parallel friction-enhancing strips per roll laid lengthways, minimum width 15 cm).

- ⑬ - rolls loaded in one or several tiers with a total height greater than the vertical part of the sliding wall are secured by means of
- lateral scotch in contact with the goods **or**
  - lateral guide-pieces **or**
  - non-slip material/packageing

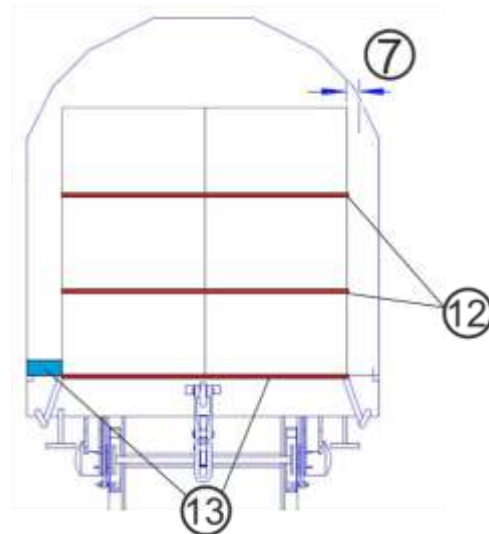

#### Additional indications

Load of wagons: see information sheet 0.1,

Single-use bindings<sup>2)</sup>: see information sheet 0.6,

Friction and coefficients of friction: see information sheet 0.8.

<sup>1)</sup> For example, profiled tubes of height 5 cm; the upper edge facing the goods should be rounded off to avoid causing damage

<sup>2)</sup> The minimum breaking strength (straight pull) corresponds to double the permitted tensile force (LC); this concerns only synthetic straps, woven straps and load securing straps, as well as lashing steel wire ropes and lashing chains.

## 4.1.5 Rolls of paper

Single wagons and groups of wagons

Wagons in block trains or combined transport  
Wagons with long-stroke shock absorbers

### Type of goods

Paper rolls

### Wagons

Wagons with wooden floors, mechanically-operated curtain sides and fixed end walls

### Method of loading

Rolls should be loaded:

- **upright**, diameter at least  $\frac{5}{10}$  of the height of the rolls, in contact with each other, unstacked and in a single group, in two symmetrical or staggered lines, covering as much of the floor surface as possible.
- ① At least one end of each line of rolls must be in contact with the end wall. Any loading gaps between the last rolls and the end wall must be as small as possible;
- ② - **lying lengthways**, covering as much of the floor surface as possible, one end of the line must be in contact with the end wall, in a single layer with one or two lines in direct contact with each other.
- ③ - **lying crossways**, in one or several groups covering as much of the floor surface as possible, in contact with the end walls.
- ④ If the rolls are loaded on top of each other the lower layer shall cover the whole of the wagon floor, the upper layer shall be dovetailed, with the heaviest and thickest rolls placed in the lower layer. The rolls in the upper layer are either of the same length or shorter than the rolls in the lower layer;
- ⑤ - **lying crossways**, in one or several groups covering as much of the floor surface as possible, in contact with the end walls.
- ⑥ If rolls are dovetailed the heaviest and thickest rolls shall be placed in the lower layer and, if necessary, separated from each other so as to ensure that the rolls in the upper layer do not prevent the sheeting being closed. The resulting gap must not be greater than 93 cm.

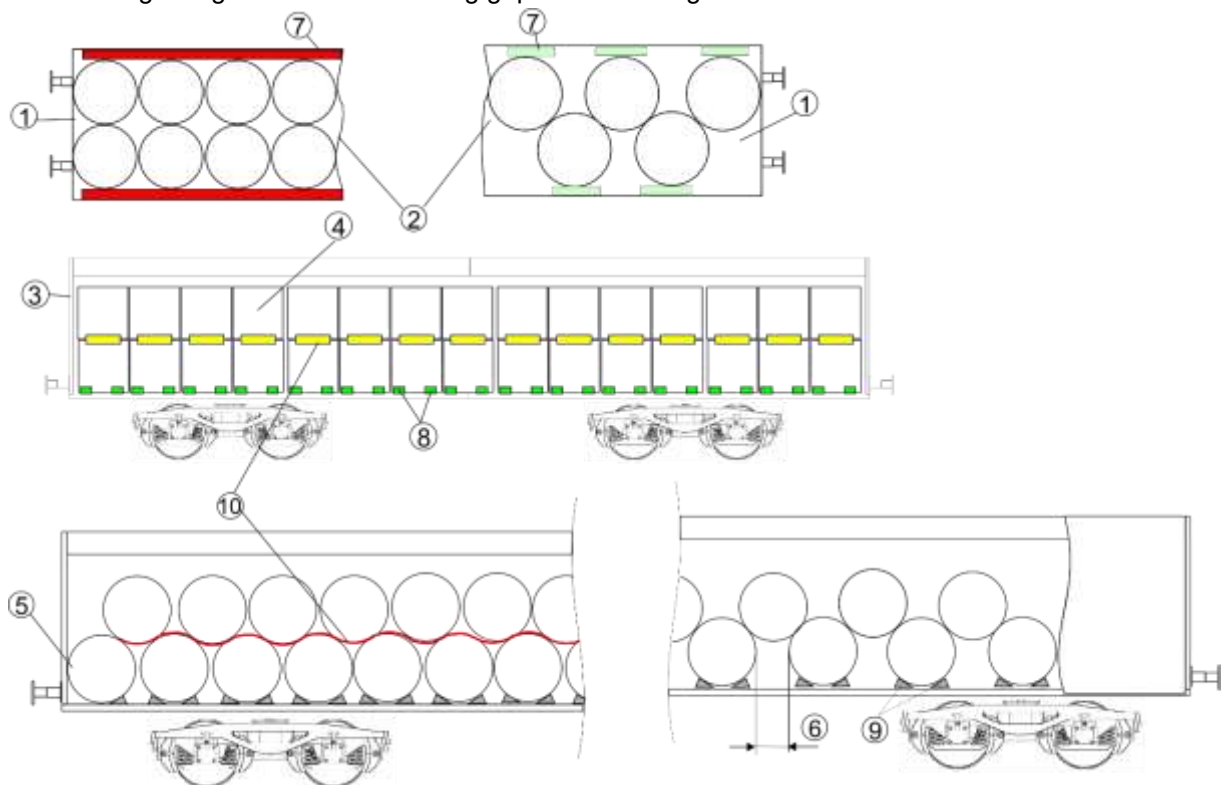

#### 4.1.5

##### Securing

- ⑦ Rolls loaded **upright** are secured against crossways movement by continuous scotches or scotches positioned at regular intervals. The scotches are nailed in place and have an effective height of at least 3 cm.
- ⑧ Rolls loaded **lengthways** in the wagon, in case of a single line, are secured by four nailed and sufficiently wide scotches per roll. Where rolls are loaded in two lines which are in direct contact with each other they shall be secured by two scotches per roll.  
The scotches shall be positioned at least 20 cm from the outer edge of the rolls.
- ⑨ Rolls loaded **crossways** in the wagon are secured by scotches distributed over the whole of the loading length, where possible with every second roll secured by two nailed scotches. Rolls which are not supported by any other rolls shall be secured by four scotches positioned along the sides.
- ⑩ Rolls on the upper layer are secured by adhesive straps and, in order to prevent crossways movement, friction inserts shall be positioned between each roll of the two layers approximately 15 cm from the roll edges, or another suitable method shall be used.

##### Additional indications

Load of wagons: see information sheet 0.1

Friction and coefficients of friction: see information sheet 0.8

## 4.1.6 Rolls of paper loaded “gunshot” (eye-to-end)

Single wagons and groups of wagons

Wagons in block trains or combined transport  
Wagons with long-stroke shock absorbers

### Type of goods

Rolls of paper

### Wagons

Wagons with sliding walls, mechanically-operated curtain sides and fixed end walls (H..., Kils..., Li..., Rils..., Si...) and equipped with special devices for fixing scotches (stanchion pockets, holes to bolt down partition walls, graduated slides, etc.).

### Method of loading

Rolls should be loaded

- ① - in a single tier on the wagon floor next another with similar diameter and; rolls in the upper tier may be dovetailed, with the diameter of the dovetailed rolls not larger the diameter of the lower tier rolls.
- ② - without touching either the sliding walls, the curtain sides or the stanchions
- ③ - in close succession starting from the end walls

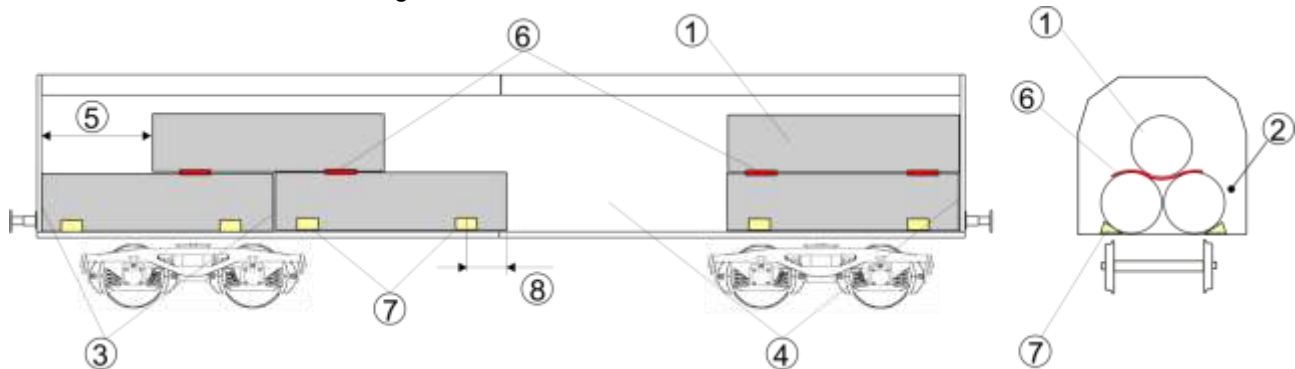

### Securing

- Lengthways in the wagon:
  - ④ • Rolls of the lower tier by end board or walls able to slide
  - ⑤ • Rolls of the upper tier when loaded in dovetailed formation end rolls secured by end board or walls or inset by one half-length of a roll and
  - ⑥ • by two strips made from friction-enhancing inserts, minimum width of 15 cm; the friction coefficient, resistance to deformation and average resistance to dirt shall be guaranteed by the manufacturer.
- Across the wagon:
  - ⑦ • by scotches (screw-in scotches, etc.) firmly fixed to the wagon
    - height of at least 20 cm
    - sufficiently wide to ensure proper stability of the scotch and protect the load and to allow unhampered movement in the longitudinal direction
    - scotch angle of approx. 45°, edges rounded
  - ⑧ • Clearance from centre of scotch to ends of rolls at least 50 cm

### Additional indications

Load of wagons: see information sheet 0.1

Friction and coefficients of friction: see information sheet 0.8.



## 4.2.1 Wood pulp in bales (individual bales)

Single wagons and groups of wagons

Wagons in block trains or combined transport  
Wagons with long-stroke shock absorbers

### Type of goods

Wood pulp in bales, bound lengthwise and across with bands (breaking strength of bindings at least 700 daN)

### Wagons

Wagons with sides or stanchions

### Method of loading

Bales should be

- ① - evenly spread over the full loading surface, wherever possible without gaps,
- ② - in tiers of the same height, symmetrically stacked.

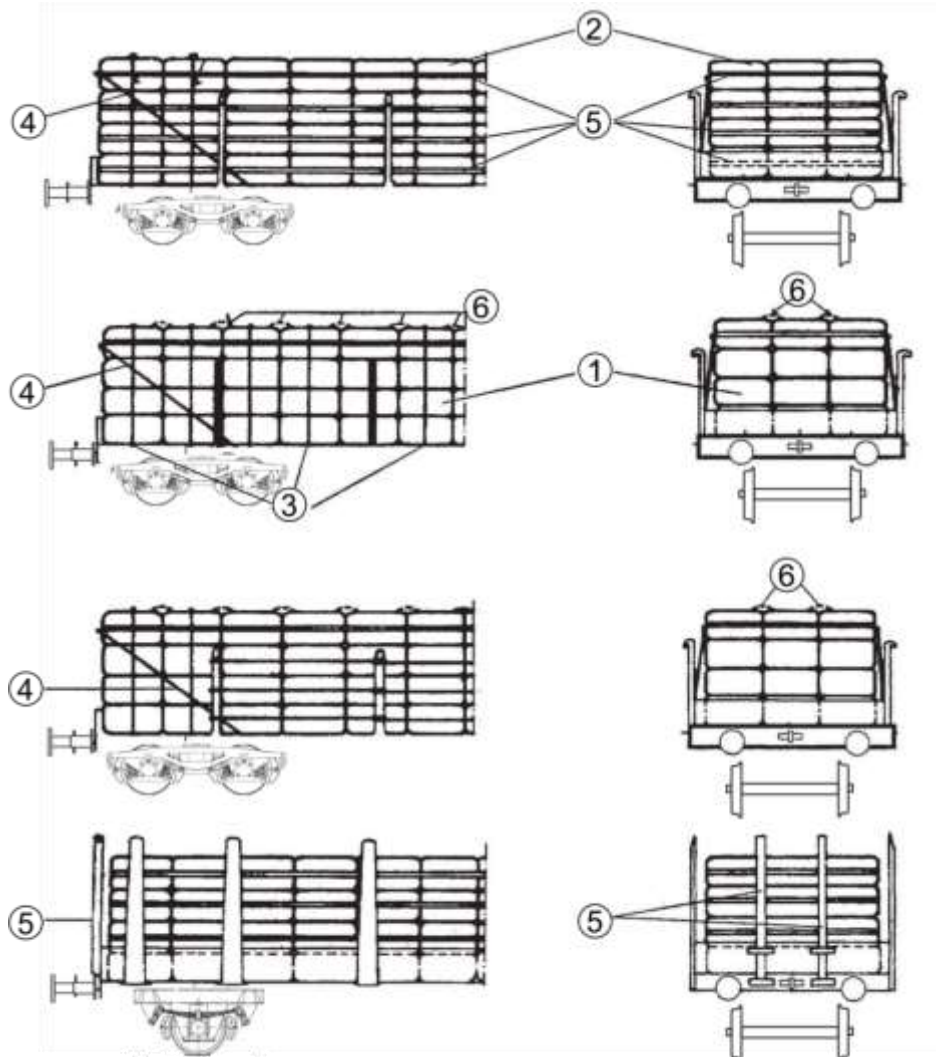

### Securing

- ③ - Each stack should be secured with an indirect fastening (breaking strength at least 1000 daN).
- ④ - First and second stacks from the end of the load should be fastened obliquely if the tiers insufficiently secured by the end stanchions.
- ⑤ - Each tier that is not sufficiently secured by the sides or stanchions should be bound round with bands.
- ⑥ - Bales in each tier that projects above the stanchions should be bound together both lengthwise and crosswise (breaking strength of the bindings should be at least 1000 daN).

### Additional indications

Load of wagons: see information sheet 0.1.

Single-use bindings<sup>1)</sup>: see information sheet 0.6.

<sup>1)</sup> The minimum breaking strength (straight pull) corresponds to double the permitted tensile force (LC); this concerns only synthetic straps, woven straps and load securing straps, as well as lashing steel wire ropes and lashing chains.



## 4.2.2 Wood pulp in bales (in units)

Single wagons and groups of wagons

Wagons in block trains or combined transport  
Wagons with long-stroke shock absorbers

### Type of goods

Wood pulp in bales, bound lengthwise and crosswise with bands

- ① - six or height bales should be bound together to form a single load unit, no higher than 190 cm (breaking strength of the bindings at least 700 daN)

### Wagons

Wagons with sides or stanchions

### Method of loading

Load units should be

- ② - spread evenly and without gaps over the full loading surface  
③ - at the ends, at least one row end-on (lengthwise)  
④ - placed lengthwise or crosswise in the wagon

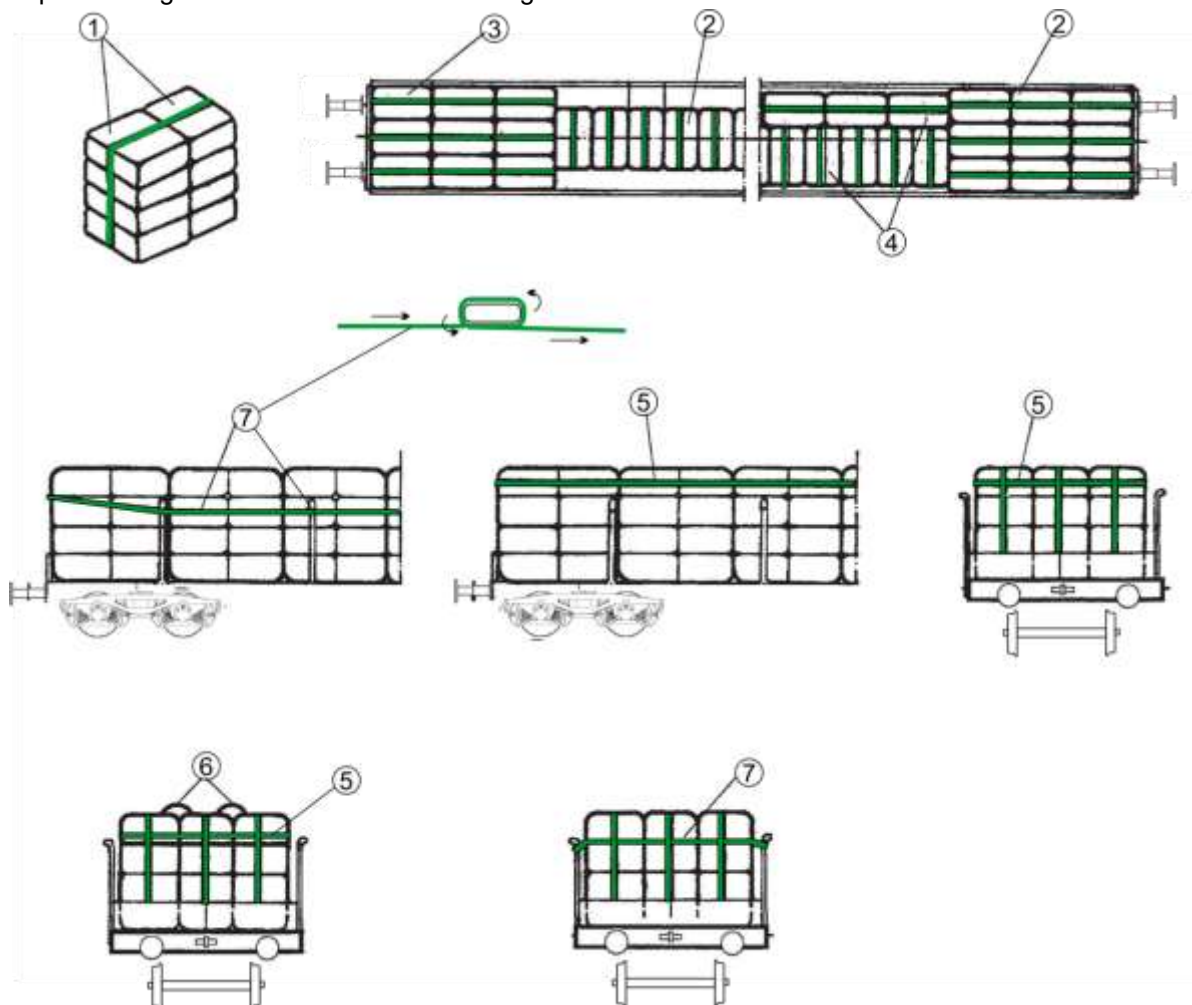

### Securing

- ⑤ The upper bales in a unit should be encircled with a band secured against slipping off.  
⑥ Adjacent load units should be bound together **or**  
⑦ Stanchions should be tied together horizontally in the top third, transverse fastening at each stanchion, e.g. looped (Breaking strength of binding must be at least 1000 daN).

### Additional indications

Load of wagons: see information sheet 0.1.

Single-use bindings<sup>1)</sup>: see information sheet 0.6.

<sup>1)</sup> The minimum breaking strength (straight pull) corresponds to double the permitted tensile force (LC); this concerns only synthetic straps, woven straps and load securing straps, as well as lashing steel wire ropes and lashing chains.



## **Chapter 5: Reserved**



## **Chapter 6: Stone and construction materials**



## 6.1.1 Blocks of stone (worked)

Single wagons and groups of wagons

Wagons in block trains or combined transport  
Wagons with long-stroke shock absorbers

### Type of goods

Blocks of stone (worked)

### Wagons

Wagons with walls, sides or stanchions and wooden floor

### Method of loading

- ① Blocks should be loaded in one or two tiers, lying flat, and wherever possible spread over the whole loading surface, with or without intermediate space.
- ② - with their broadest surface to the wagon floor **or**
- ③ - lying in a stable position on softwood timbers (1 to 4 cm thick).
- ④ Stacked blocks of stone should be separated by cross-timbers, plaited straw or thick ropes/cables and bound together at least twice into load units (breaking strength at least 1400 daN).

### ⑤ Minimum clearances

smooth bearing surface	50 cm		0 cm
rough bearing surface	30 cm		0 cm

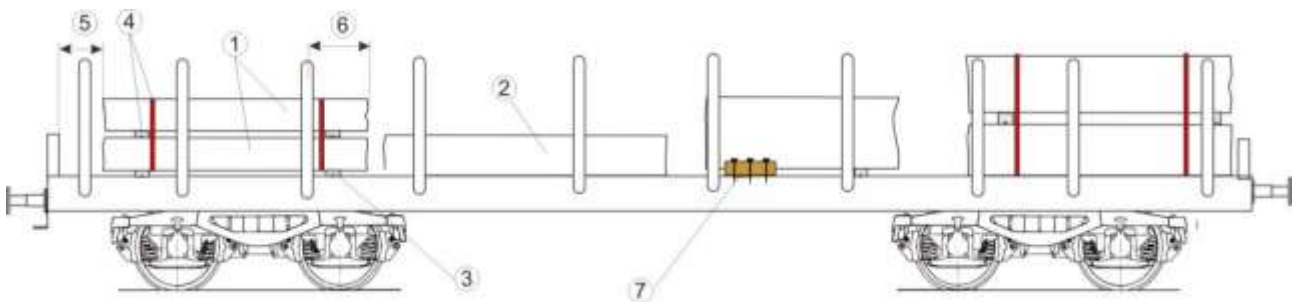

### Securing

Blocks should be secured by the wagon walls, sides or at least two stanchions.

- ⑥ - when secured by only two stanchions, blocks should extend lengthways beyond the stanchion centre by at least
 

smooth bearing surface	50 cm		30 cm
(rough bearing surface)	30 cm		20 cm
- ⑦ - by guide-pieces when ⑥ is not complied with or when the blocks of stone are more than 10 cm away from the walls, sides or stanchions
  - guide-pieces should be at least 5 cm thick with an effective height of at least 3 cm
  - total number of nails (of 5 mm diameter) along each side: one nail/1500 kg, and at least two nails per guide-piece.

Blocks<sup>1)</sup> which are not directly secured laterally by the wagon walls, sides or stanchions must be laterally secured with guide-pieces.

### Additional indications

Load of wagons: see information sheet 0.1

Single-use bindings<sup>2)</sup>: see information sheet 0.6.

1) Except blocks with rough bearing surface

2) The minimum breaking strength (straight pull) corresponds to double the permitted tensile force (LC); this concerns only synthetic straps, woven straps and load securing straps, as well as lashing steel wire ropes and lashing chains.



## 6.1.2 Blocks of stone (unworked)

Single wagons and groups of wagons

Wagons in block trains or combined transport  
Wagons with long-stroke shock absorbers

### Type of goods

Blocks of stone, unworked (with rough surface)

### Wagons

Wagons with walls or sides and wooden floor (E..., K..., Re...,)

### Method of loading

Blocks should be loaded lying flat

- wherever possible spread over the whole loading surface, with or without intermediate space
- ① - with their broadest surface to the wagon floor and with irregularities compensated using wooden timbers to ensure that a stable position result.

- ② Minimum clearances

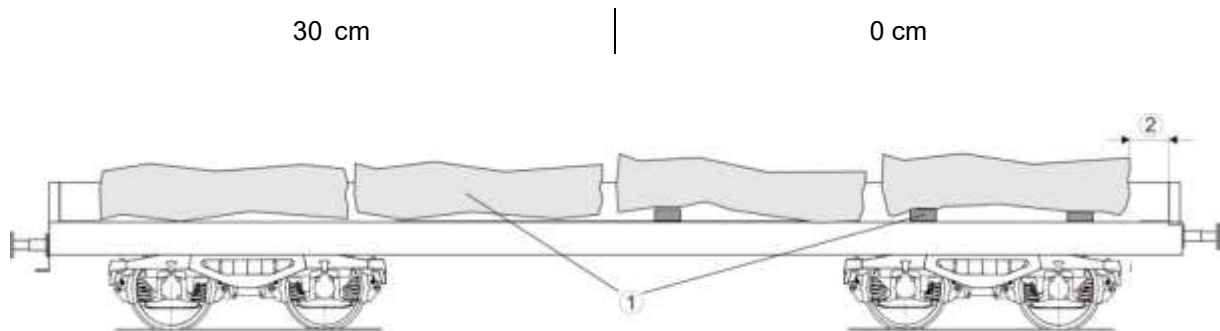

### Securing

Blocks should be secured by their own friction and by the wagon walls or sides.

### Additional indication

Load of wagons: see information sheet 0.1



## 6.2 Stone and concrete slabs on steel trestles (sliding method of loading may be used, except for goods loaded in intermodal loading units (ILUs))

Single wagons and groups of wagons

Wagons in block trains or combined transport  
Wagons with long-stroke shock absorbers

### Type of goods

- ① - Stone and concrete slabs on A-frame steel trestles
  - ② - trestle bearing surface inclined at an angle of at least 12°
  - ③ - trestle skids should be obliquely positioned, with small spikes or weld beads under the skids, about 3 mm high and perpendicular to the direction of sliding
- The sliding method of loading may not be used if these goods are loaded in an ILU.

### Wagons

Wagons with walls, sides or stanchions and a wooden floor

ILU on container wagon

### Method of loading

- ④ Trestles should be loaded lengthwise
- ⑤ The same number of slabs of similar dimensions should be placed on either side of the trestle.
- ⑥ Slabs should extend beyond the trestle by around 50 cm at either end
- ⑦ Each stack should be directly fastened to the trestles at least twice (breaking strength<sup>1)</sup> at least 4000 daN), with corner protections.
- ⑧ Several load units may be placed one behind another at intervals of at least 50 cm as appropriate.
- ⑨ Minimum clearances:

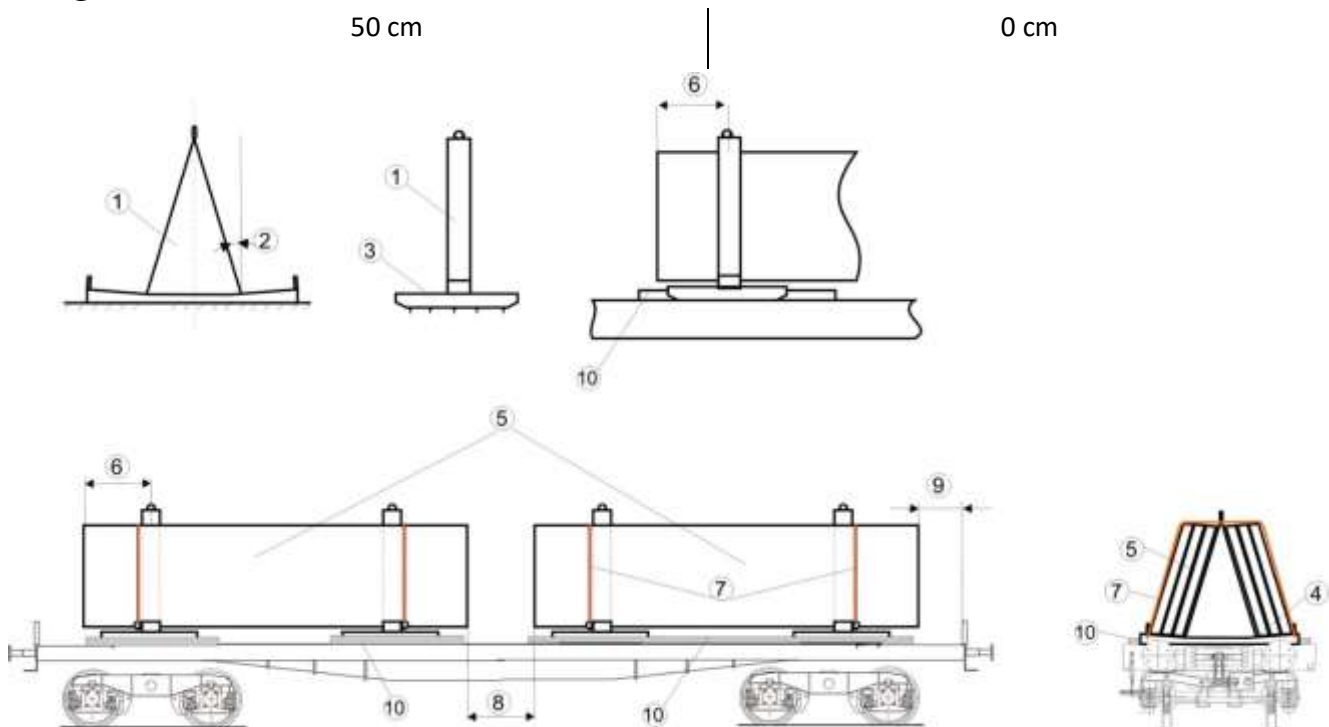

<sup>1)</sup> The minimum breaking strength (straight pull) corresponds to double the permitted tensile force (LC); this concerns only synthetic straps, woven straps and load securing straps, as well as lashing steel wire ropes and lashing chains.

## 6.2

### Securing

The trestles

⑩ should be secured laterally on the wagon using wooden guide-pieces

Inside the ILU

Direct fastenings **or**  
anti-skid materials (no spikes or weld beads under the  
skids for the trestles), combined with indirect  
fastenings. Breaking strength of bindings (straight pull):  
at least 4000 daN.

- Thickness of wooden guide-pieces: at least 5 cm with an effective height of at least 3 cm
- Total number of nails of diameter 5 mm along each side: one nail/1500 kg load weight, with at least two nails per wooden guide-piece.

#### Additional indications

Load of wagons: see information sheet 0.1

Indirect fastenings: see information sheet 0.7

Friction and coefficients of friction: see information sheet 0.8.

## 6.3 Concrete sleepers loaded crossways

Single wagons and groups of wagons

Wagons in block trains or combined transport  
Wagons with long-stroke shock absorbers

### Type of goods

Concrete sleepers with ribbed baseplates or angled guide plates (support and fastening elements for rails) with or without a synthetic support surface.



*Sample images of concrete sleepers*

### Wagons

Specially designed wagons or equipped with loading devices, with end and if necessary, (folding) inner stanchions and each provided with wooden timbers fixed lengthways to the wagon.



### Method of loading

Sleepers loaded crossways and centered lengthways to the wagon.

Position of the load:

- ① - Lowest layer rests on the attached wooden timbers to the wagon floor
- ② - The intermediate timbers are inserted in the ribbed baseplates or into the corresponding cut outs in the sleepers below them
- ③ - Above the top layer in the corresponding cut outs of the end timbers
- ④ If possible, each layer loaded crossways and centered lengthways to the wagon. In case of existing inner stanchions, layers between outer and inner stanchions filled.
- ⑤ If the layers cannot be fully filled due to technical reasons, then the sleepers should be loaded against the end stanchions.
- ⑥ A maximum distance of 10 cm between the sleepers is permissible for loading reasons.
- ⑦ The sleepers may exceed the height of the stanchions, but the effective height of the top layer must be at least 5cm.
- ⑧ End and inner stanchions are equipped with permanently integrated squared timbers **or** are doubled with vertically inserted squared timbers (only used if necessary to protect the sleepers from damage). Not integrated squared timbers shall be secured against loss by being fastened to the top and bottom of the stanchion by means of wire bindings with a minimum diameter of 4 mm.

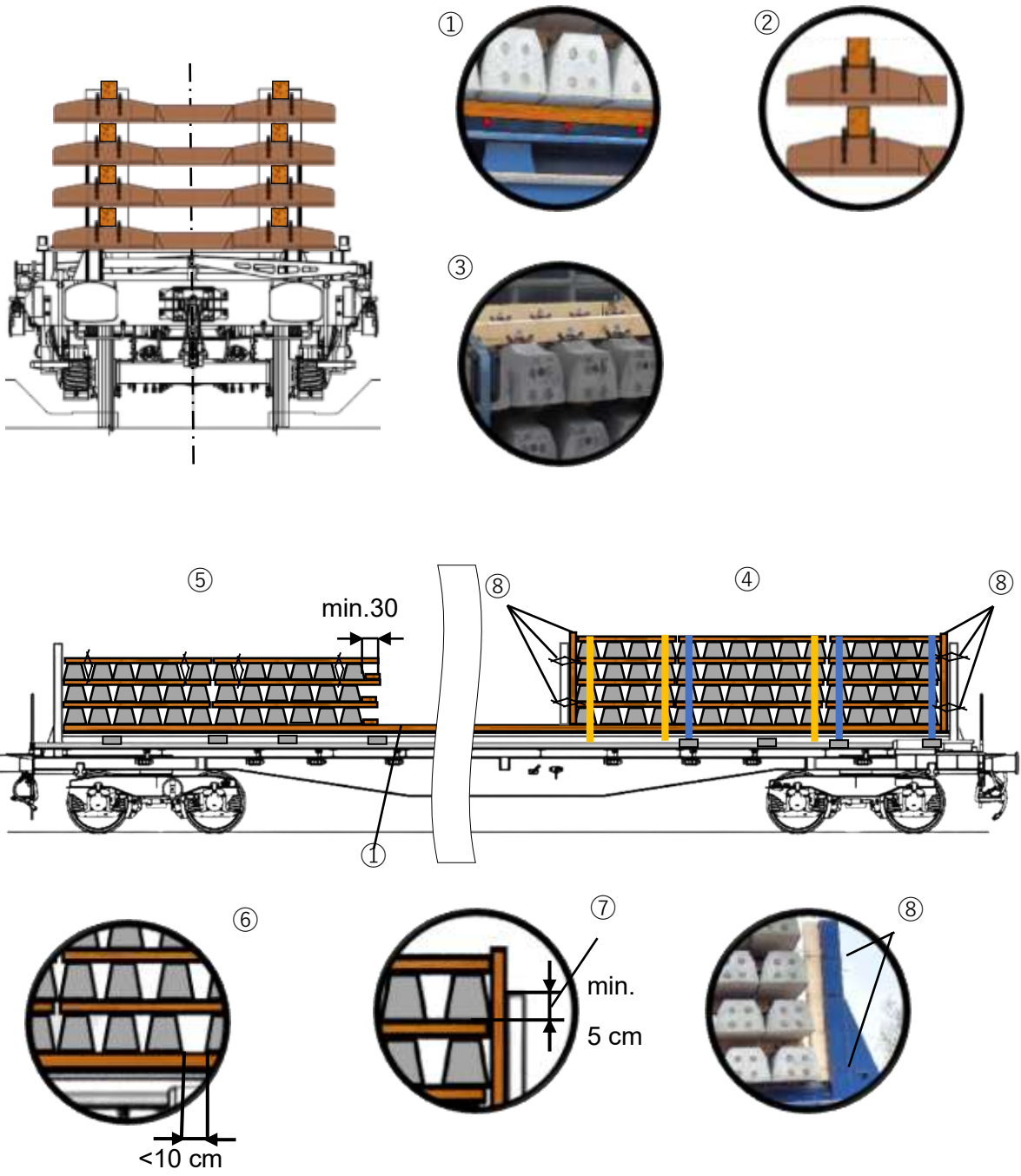

## Nature, number, and placement of the intermediate and end timbers

### ⑨ Intermediate and end timbers:

- Made from healthy and undamaged wood
- Dimensions (height x width) approx. 10x8 cm
- Length min. 150 cm
- inserted in the area of the ribbed baseplates or in the ribbed baseplates or in the cut outs in the sleepers
- arranged one behind the other lengthways in the wagon without a gap

For not fully filled layers, the intermediate and end timbers overhang the sleepers by at least 30 cm

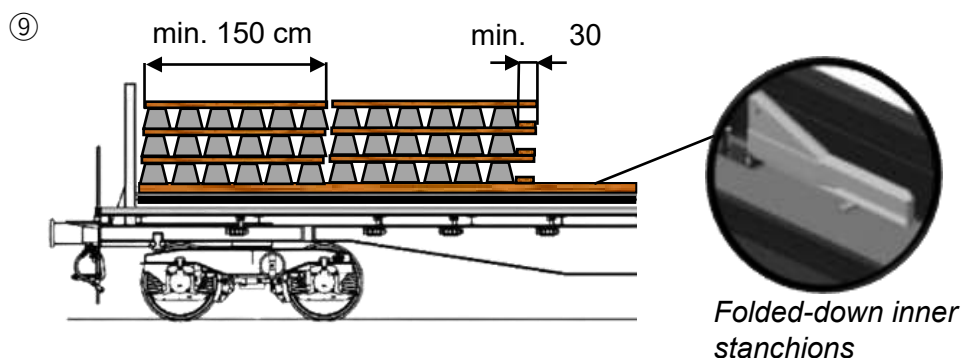

## Securing

Sleepers secured lengthways:

- ⑩ a - for fully filled layers, by direct contact of the sleepers against the stanchions (if necessary, against the squared timbers)
- ⑩ b - for not fully filled layers, towards the centre of the wagon by means of boundary timbers. These lie on the intermediate timbers with their entire length of approx. 30 cm and are fastened to them with 4 nails each with a minimum diameter of 5 mm.

Sleepers secured crossways through:

- friction between the rough concrete surface/wood (only valid for concrete sleepers without a synthetic support surface) **and**
- the inserted intermediate and end timbers **and**
- the suitable indirect fastenings or wire bindings

- ⑪ Securing per length of the end timber by at least two bindings through indirect fastening systems integrated into the wagon or through additionally attached indirect fastenings with a minimum breaking strength (straight pull) of 3000 daN.

Distance of the bindings from the respective ends of the end timbers min. 30 cm.

Each indirect fastening runs centrally over the sleeper and is protected with padding, flexible protective material or corner pieces in the area of contact with the sleeper to prevent possible abrasions.

- ⑫ Loading sleepers **without** a synthetic lower support surface:

If the number or the required distances between the indirect fastenings cannot be observed due to the arrangement of the fittings on the wagon, the end timbers can be secured through bindings made of steel wire with a minimum diameter of 4 mm instead of the required indirect fastenings. The wire bindings are to be attached after the respective first/last sleeper based on the position of the end of the end timbers to the intermediate timbers below.

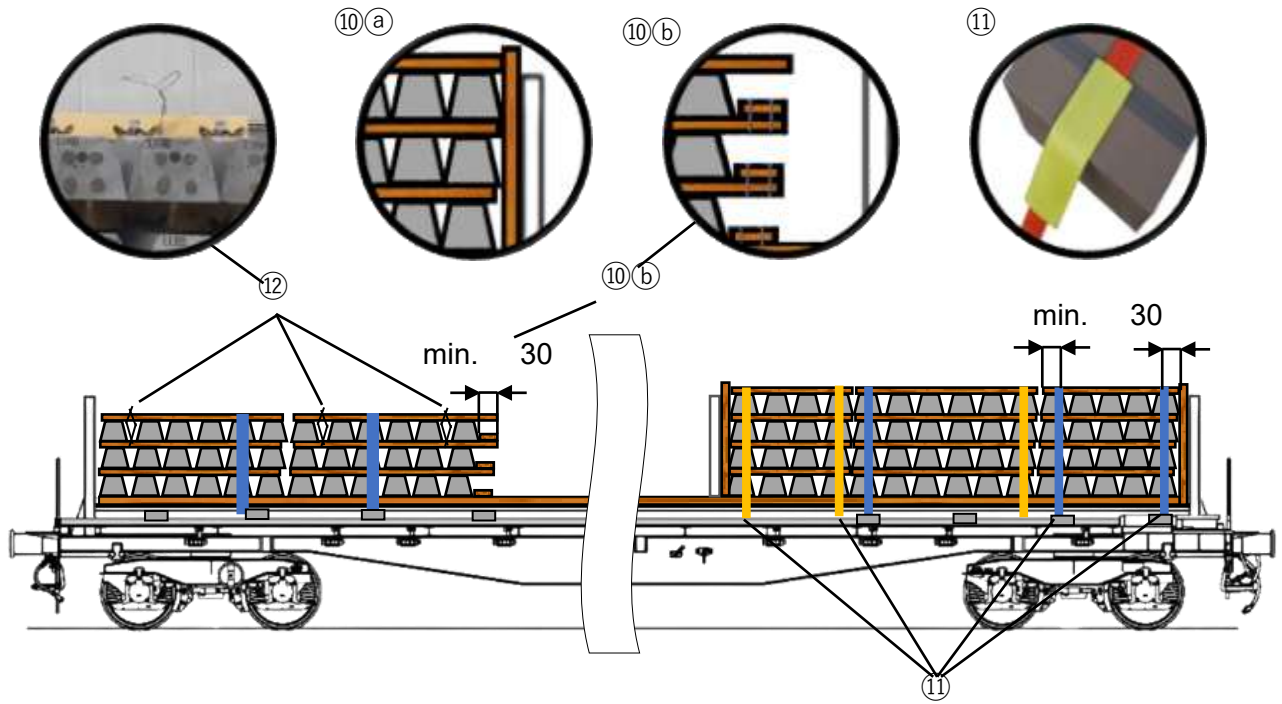

### Additional indications

Load of wagons: see information sheet 0.1,  
 Maximum dimensions of loads: see information sheet 0.2.

## **Chapter 7: Vehicles and machinery**



## 7.1

④ Number of scotches on each side, along the length of the wagon:

- wheeled vehicles	4	2
- caterpillar vehicles/1-axle trailers	2	2

Number of nails of approx. 5 mm diameter used for longitudinal securing as follows:

Vehicle weight up to	Number of nails per scotch on		Number or nails per scotch on	
	Unbraked wheels	Braked wheels	Unbraked wheels	Braked wheels
2 t	2	2	2	2
3 t		3		
4 t		4		
5 t		5		
6 t	3	6		3

Number of nails of approx. 5 mm diameter used for longitudinal securing for wagons secured according to ③ with fixed bindings and wooden scotches with nailed extension:

Over 6 to 12 t	6	9	3	4
----------------	---	---	---	---

⑤ Number of scotches/guide-pieces across the width of the wagon on each side (inside or outside):

- wheeled vehicles (scotches): 2
- caterpillar vehicles (guide-pieces at least 5 cm high) min.: 2

Number of nails used for lateral securing as follows:

Vehicles weight up to	Number of nails per	
	Scotch	Guide-piece
4 t	2	4
6 t	3	
10 t	4	
16 t	5	
24 t	6	6
32 t	-	8

Sliding, swinging or turning parts (such as crane booms, lifting devices, counterweights or cabs of vehicles and machinery) shall be mechanically secured or fastened so they are unable to move during transit (breaking strength of bindings min. 1000 daN, for crane booms min. 4000 daN).

The draw-bars of uncoupled trailers must be indirectly fastened (breaking strength of bindings at least 1000 daN).

⑥ Uncoupled semitrailers not loaded onto piggyback wagons with integrated support structures must be supported as appropriate in the area of the trailer base. The support structures used must be protected against falling over and must be sufficiently strong and fastened to the wagon. The vehicle's support structures must then be released.

⑦ Direct fastenings must also be attached in this case. The fixed bindings correspond to loading method 7.2.

### Additional indications

- Load of wagons: see information sheet 0.1,
- Maximum dimensions of loads: see information sheet 0.2,
- Single-use bindings<sup>1)</sup>: see information sheet 0.6,
- Indirect fastenings<sup>1)</sup>: see information sheet 0.7

<sup>1)</sup> The minimum breaking strength (straight pull) corresponds to double the permitted tensile force (LC); this concerns only synthetic straps, woven-fabric straps and load securing straps, as well as lashing steel wire ropes and lashing chains.



## 7.2 Vehicles and machinery on wheels or caterpillar tracks, secured with fastenings

Single wagons and groups of wagons

Wagons in block trains or combined transport  
Wagons with long-stroke shock absorbers

### Type of goods

Motor cars, lorries, trailers, diggers, bulldozers, cranes

- vehicle canopies or bonnets should be closed and secured
- aerials should be retracted, detached or folded back
- engines should be secured against spontaneously starting up
- tyres inflated to normal service pressure

### Wagons

Wagons with wooden floors

### Method of loading

Vehicles and machinery should be loaded lengthways in the wagon

- ① Minimum clearances to the fixed parts of the wagon and between vehicles

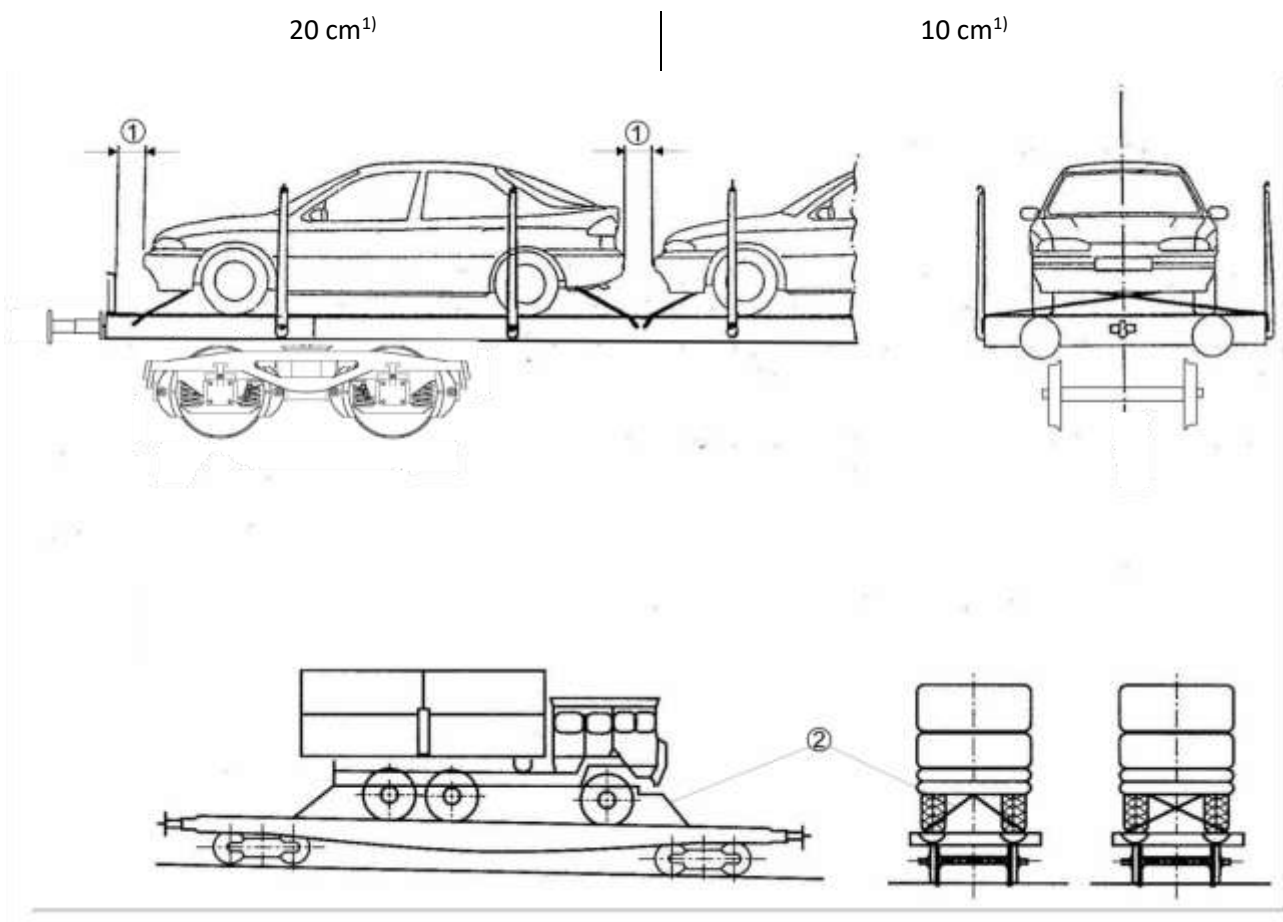

<sup>1)</sup> Take account of extra space needed for fastenings

## 7.2

### Securing

② Vehicles and machinery should be secured as follows

- two fastenings, taut and independent of one another, to be applied to each end of vehicles and machinery, effective both lengthways and crossways
- hand-brakes on and lowest gear engaged, or gears blocked; vehicles that cannot be secured in any of these ways should also be scotched (see loading method 7.1)

For the strength of the fastenings used, consult the following tables:

Vehicle weight up to		Breaking strength <sup>2)</sup> of fastenings	Breaking strength <sup>2)</sup> of fastenings
Wheeled vehicles	Caterpillar vehicles		
3t	5 t	4000 daN	2000 daN
8 t	10 t	8000 daN	4000 daN
15 t	25 t	12500 daN	8000 daN
30 t	50 t	20000 daN	12500 daN
40 t	60 t	32000 daN	20000 daN
42 t	65t	40000 daN	25000 daN
	70 t	50000 daN	38000 daN

For vehicles of up to 3 t, fastenings made of wire (diameter of at least 4 mm) may be used.

Each fastening must comprise

four wires of 4 mm diameter each

two wires of 4 mm diameter each

Sliding, swinging or turning parts (such as crane booms, lifting devices, counterweights or cabs of vehicles and machinery) shall be mechanically secured or lashed down so they are unable to move during transit (breaking strength of bindings min. 1000 daN, for crane booms min. 4000 daN).

The draw-bars of uncoupled trailers must be indirectly fastened (breaking strength of bindings at least 1000 daN).

For uncoupled semitrailers not loaded onto piggyback wagons with integrated support structures, see loading method 7.1, points ⑥ and ⑦.

### Additional indications

Load of wagons: see information sheet 0.1,

Maximum dimensions of loads: see information sheet 0.2,

Single-use bindings<sup>3)</sup>: see information sheet 0.6,

Indirect fastenings<sup>3)</sup>: see information sheet 0.7.

<sup>2)</sup> Bands and load securing straps used as slings are considered to have twice the breaking strength as in straight pull.

<sup>3)</sup> The minimum breaking strength (straight pull) corresponds to double the permitted tensile force (LC); this concerns only synthetic straps, woven-fabric straps and load securing straps, as well as lashing steel wire ropes and lashing chains.

## 7.3 Wheeled vehicles

Single wagons and groups of wagons

Wagons in block trains or combined transport  
Wagons with long-stroke shock absorbers

### Type of goods

Motor cars, lorries, trailers, diggers, bulldozers, cranes

- vehicle canopies or bonnets should be closed and secured
- aerials should be retracted, detached or folded back
- engines should be secured against spontaneously starting up
- tyres inflated to normal service pressure

### Wagons

Flat wagons, permanently-coupled flat wagon units and double-decker car carrying wagons (La....), equipped with wheel scotches with a 45° angle that are

- ① - equipped with a supporting arm or
- ② - retractable

### Method of loading

- ③ Load lengthways in the wagon, with scotches laid against the wheels at an angle of approx. 45°. Vehicles should have handbrake on and low gear engaged, or gears blocked

Vehicles may be loaded over the coupling of permanently coupled units (but see ⑧)

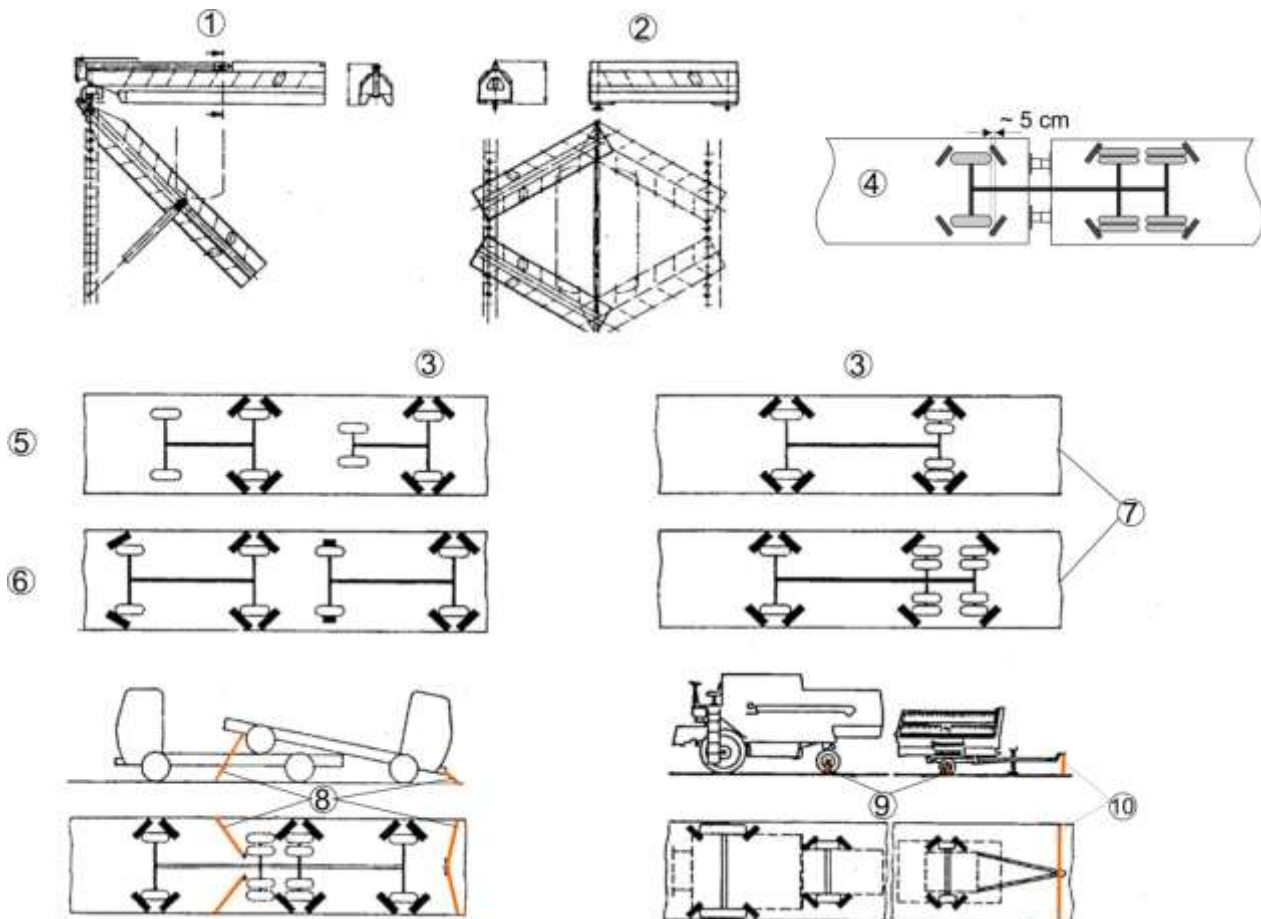

### Securing

- ④ On the unbraked axle: scotching independently from vehicle weight with 5 cm play.
- ⑤ For motor cars and vehicles with a wheelbase of max. 3000 mm and a weight of up to 5.5 t, the scotches are applied to the wheels of the braked axle only.
- ⑥ For other vehicles up to a weight of 5.5 t, the front axle also should be either secured by scotches or secured laterally using scotches or guide-pieces.
- ⑦ For vehicles weighing over 5.5 t, each wheel of the front axle should also be secured with two scotches.

### 7.3

- ⑧ Bindings (two each front and rear, breaking strength 4000 daN) are also required for
- vehicles that are not securely braked or immobilised
  - vehicles loaded in staggered formation
  - vehicles weighing over 20 t (5.5 t if secured on one axle)
  - vehicles with wheel diameter of over 1900 mm

In those cases, vehicles may not be loaded over the coupling of permanently-coupled units.

- ⑨ The rear axle of combine harvesters and single-axle trailers should be secured with an additional vertical fastening (breaking strength 2000 daN).

Sliding, swinging or turning parts (such as crane booms, lifting devices, counterweights or cabs of vehicles and machinery) shall be mechanically secured or lashed down so they are unable to move during transit (breaking strength of bindings min. 1000 daN, for crane booms min. 4000 daN).

- ⑩ The draw-bars of uncoupled trailers must be indirectly fastened (breaking strength of bindings min. 1000 daN).

#### Additional indications

Wheel scotches not in use shall be secured.

Wheel scotches shall be positioned against tyres at an angle of roughly 45°. It is accepted that there be play generated between scotch blocks and tyres by the position of the apertures on the scotch guide rail. Vehicles with steered wheels in full lock shall be maintained sufficiently in this position.

Load of wagons: see information sheet 0.1,

Maximum dimensions of loads: see information sheet 0.2,

Single-use bindings<sup>1)</sup>: see information sheet 0.6,

Indirect fastenings<sup>1)</sup>: see information sheet 0.7.

---

<sup>1)</sup> The minimum breaking strength (straight pull) corresponds to double the permitted tensile force (LC); this concerns only synthetic straps, woven-fabric straps and load securing straps, as well as lashing steel wire ropes and lashing chains.

## 7.4 Wheeled vehicles

Single wagons and groups of wagons

Wagons in block trains or combined transport  
Wagons with long-stroke shock absorbers

### Type of goods

Tyred vehicles weighing up to 22 t:

- vehicle canopies or bonnets should be closed and secured
- aerials should be retracted, detached or folded back
- engines should be secured against spontaneously starting up
- tyres inflated to normal service pressure

### Wagons

Specially-designed flat wagons, permanently-coupled or double-decker wagons with corrugated iron or lath floor (L..., S...) equipped with

- ① - special wheel scotches
- moveable scotches

### Method of loading

- Load vehicles lengthways in the wagon
- Parking brake applied and low gear engaged, or gears blocked
- Scotches applied to the wheels of the braked axle, and on other wheels as required (see "Securing")

- ② Vehicles may be loaded over the coupling of permanently-coupled units.

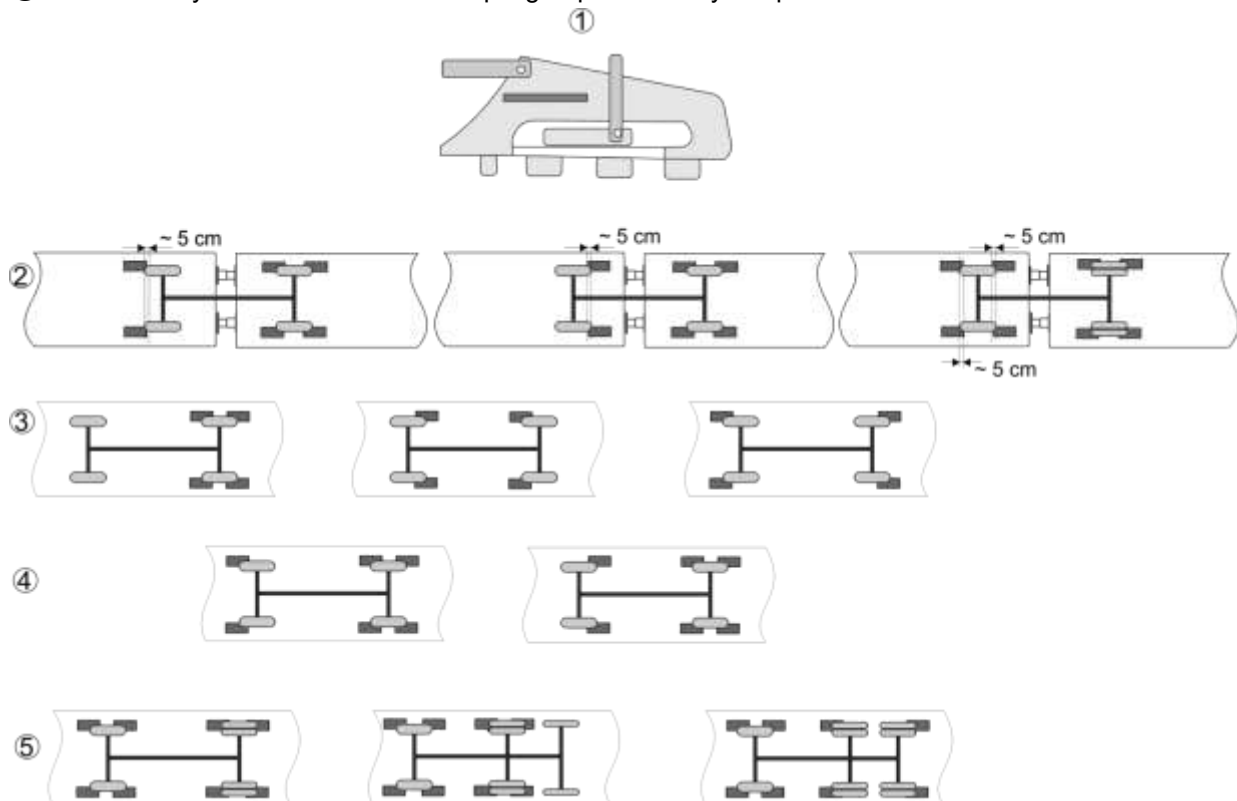

## 7.4

### Securing

In case of loading above the permanent coupling, the scotching must be made for the unblocked axle with a clearance of approximately 5 cm independent of the mass of the vehicle

Vehicles with a wheelbase of 3,1 m maximum and weighing up to

- ③ - 5 t secured with at least four wheel scotches,
- ④ - 7 t secured with at least six wheel scotches,

Vehicles with a wheelbase of over 3,1 m and weighing up to 5 t should be secured with at least six wheel scotches

#### ⑤ Vehicles weighing

- up to 12 t maximum and with wheel diameter of 1,8 m maximum secured with at least eight wheel scotches
- over 12 t and/or with a wheel diameter greater than 1,8 m, use an extra four fastenings.
  - In case of loading above the permanent coupling according to ②, the fastenings must be placed on the half-wagon where the scotches are positioned without free space with respect to the wheels.

Sliding, swinging or turning parts (such as crane booms, lifting devices, counterweights or cabs of vehicles and machinery) shall be mechanically secured or lashed down so they are unable to move during transit (breaking strength of bindings min. 1000 daN, for crane booms min. 4000 daN).

The draw-bars of uncoupled trailers must be indirectly fastened (breaking strength of bindings min. 1000 daN).

### Additional indications

Wheel scotches not in use should be suitably secured.

Load of wagons: see information sheet 0.1

Maximum dimensions of loads: see information sheet 0.2

Single-use bindings<sup>1)</sup>: see information sheet 0.6,

Indirect fastenings<sup>1)</sup>: see information sheet 0.7.

---

<sup>1)</sup> The breaking strength (straight pull) corresponds to double the permitted tensile force (LC); this concerns only synthetic straps, woven straps and load securing straps, as well as lashing steel wire ropes and lashing chains.

## 7.5 Vehicles with tyres, weighing no more than 2800 kg

Single wagons and groups of wagons

Wagons in block trains or combined transport  
Wagons with long-stroke shock absorbers

### Type of goods

Motor cars and light commercial vehicles, equipped with any type of engine (combustion, electric traction, hybrid...) up to 2800 kg:

- vehicle canopies or bonnets should be closed and secured,
- aerials should be retracted, detached or folded back,
- engines should be secured against spontaneously starting up,
- tyres inflated to normal service pressure.

### Wagons

Car carrying wagons (single or coupled, single-decker or double-decker wagons) equipped with:

- chock systems with bars and/or special locking systems on guide rails (La....),
- wheel chock systems up to 45° (La....),
- special wheel chock systems and/or removable chocks (L....; S....).

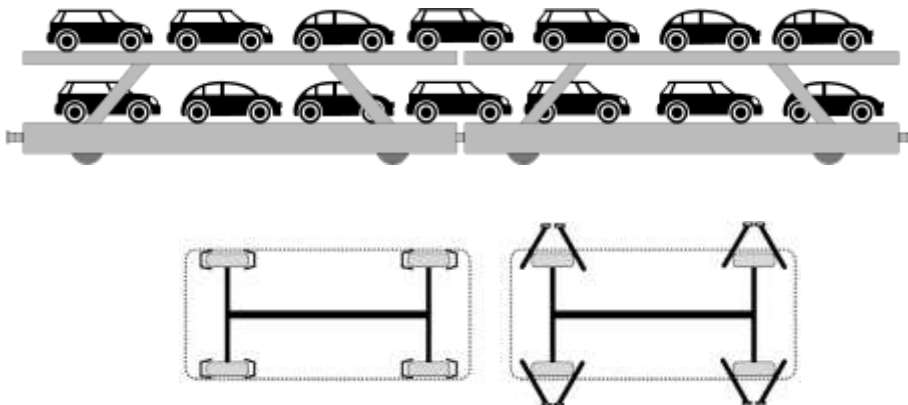

### Method of loading

Load vehicles in the centre lengthways along the wagon. Clearance between vehicles must be sufficiently large to prevent any damage. This will depend on the position of the load.

Permissible minimum longitudinal clearances between:

- ① the fixed wagon parts and vehicles parts as well as between adjacent vehicles

15 cm

10 cm

- ② two tyred vehicles, one loaded above a permanent coupling (four buffers), in the vicinity of the unsecured axle

40 cm

40 cm

- ③ two tyred vehicles, one loaded above a short coupling (two buffers, push-pull bar or Jacob axle/bogie), in the vicinity of the unsecured axle:

26 cm

26 cm

- ④ the wheels of the vehicle and the moving parts of the crossing plates above the wagon intersection:

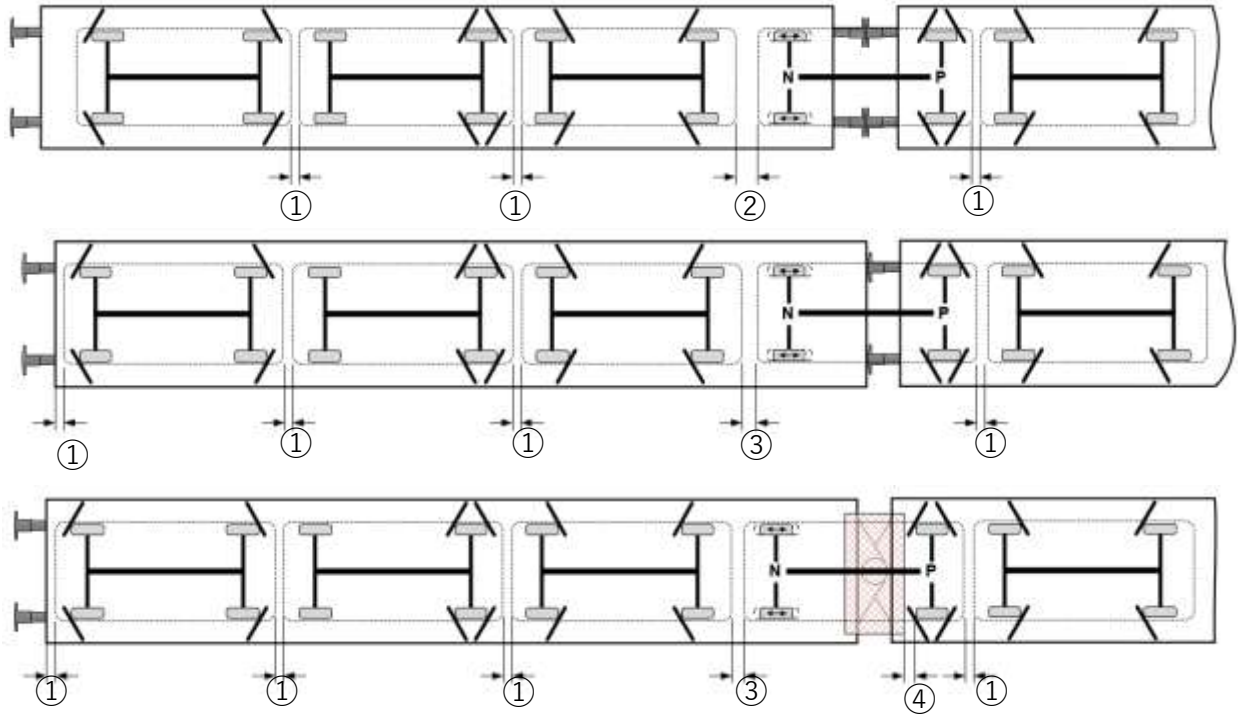

Minimum clearances to be complied with:

- in the vertical direction between the vehicle roof and the lower surface of the upper loading deck, as well as the underside of the vehicle and the wagon floor: 8 cm
- crossways in the wagon for the fixed parts of the wagons: 8 cm

**Securing**

- ⑤ Vehicles are secured by wheel scotches, if possible, positioned against tyres.
- ⑥ Clearances between wheel scotches and tyres due to the construction of the wagon and the chocking system are permitted but must be kept to a minimum.

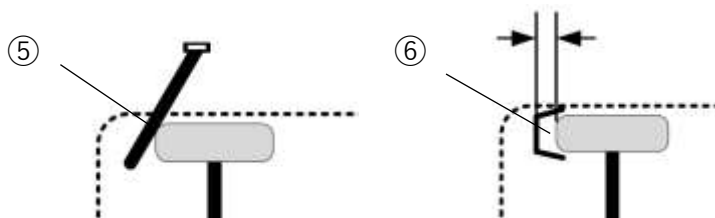

Parking brake applied for all vehicles and low gear engaged with a manual gearbox, or authorised “P” gear engaged, in accordance with the information about low gear engaged with a manual gearbox ⑦ ⑧ ⑨

Scotches applied to the wheels in accordance with one of the 3 methods below, preferably by applying wheel scotches to the braked axle by the parking brake (centre drawing).

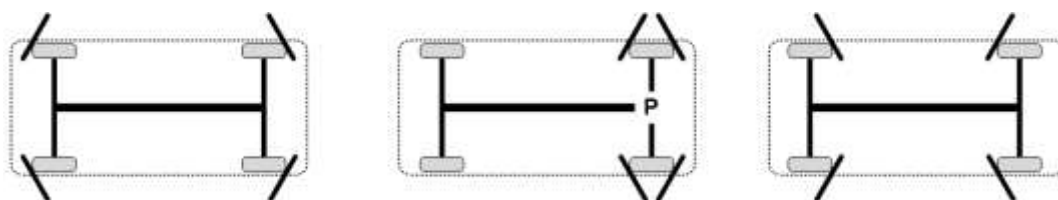

- ⑦ Vehicles loaded on the short or permanent coupling section of the wagon may only be secured on the axle on which the parking brake (**P**) is acting, using four wheel scotches.
- ⑧ The opposite axle, which rests on the other half of the wagon, must not have an active brake or the gearbox lock active. In addition, no gear must be engaged on this axle, which must be able to roll freely, to compensate for the opposite longitudinal movement and the rotational movement of the two halves of the wagon.
- ⑨ If necessary, the neutral position of this axle (**N**) must be forced by the loader during transport.

The vehicles must be secured in accordance with the following diagram:

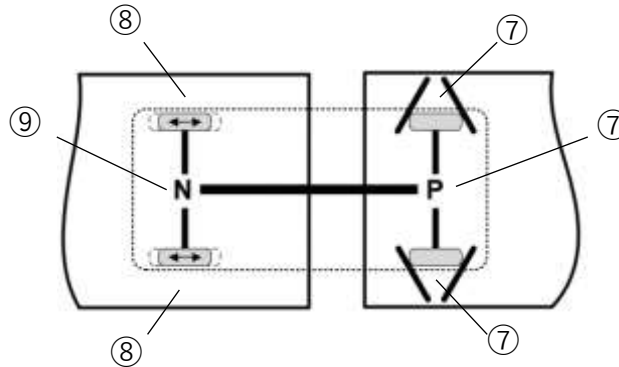

#### Additional indications

Wheel scotches not in use should be secured (apply the instructions in the wagon user manual)

Load of wagons: see information sheet 0.1

Maximum dimensions of loads: see information sheet 0.2



## 7.6 Vehicles with tyres weighing no more than 2200 kg, secured with a single scotch and forwarded by block trains

Single wagons and groups of wagons

Wagons in block trains or combined transport  
Wagons with long-stroke shock absorbers

### Type of goods

Tyred motor cars and other vehicles with tyres weighing no more than 2200 kg:

- Vehicle canopies or bonnets should be closed and secured
- Aerials should be retracted, detached or folded back
- Engines should be secured against spontaneously starting up
- Tyres inflated to normal service pressure

### Wagons

Car carrying wagons (double-decker car carrier wagons, coupled flat wagons: La...) equipped with special locking systems. The locking scotches must be fixed to the guide rails.

- ① Wagons equipped with outer and
- ② inner guide rails

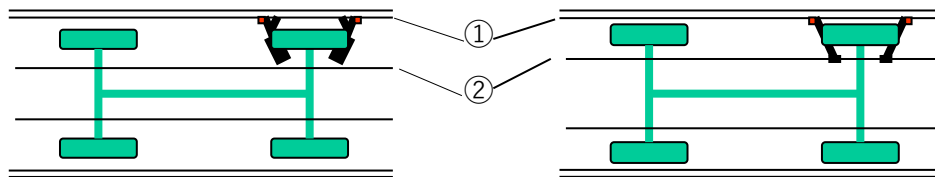

- ③ Wagons equipped with outer guide rails only.
- ④ Only for vehicles with a minimum width such that even in the event of transverse movement the vehicle remains secured in the longitudinal direction.

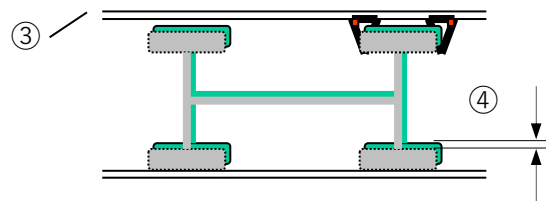

### Method of loading

- The vehicle should be loaded lengthways in the wagon,
- With the brakes on and a gear engaged or, failing this, with the gears blocked,
- Where possible the wheels should be in contact with the locking scotches,

Distance between two vehicles must be sufficiently large to prevent any damage. This will depend on:

- the type of locking scotch,
- the technical parameters of the vehicles to be carried.

Longitudinal clearance between the fixed parts of the wagons and between the vehicles approximately  
15 cm

- ⑤ Distance to be left between two tyred vehicles loaded above or in the vicinity of a short coupling (two buffers):

26 cm

- ⑥ Distance to be left between two tyred vehicles loaded above or in the vicinity of a permanent coupling (four buffers):

40 cm

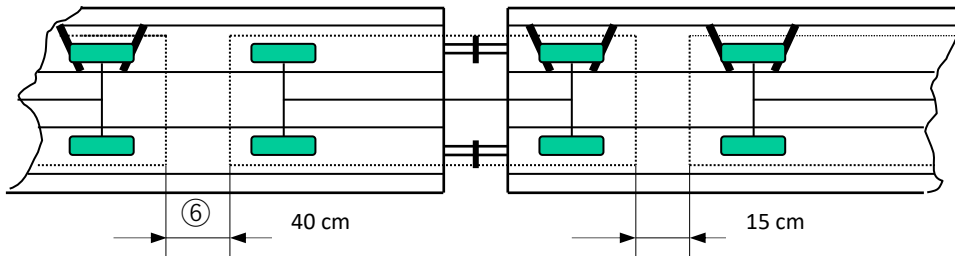
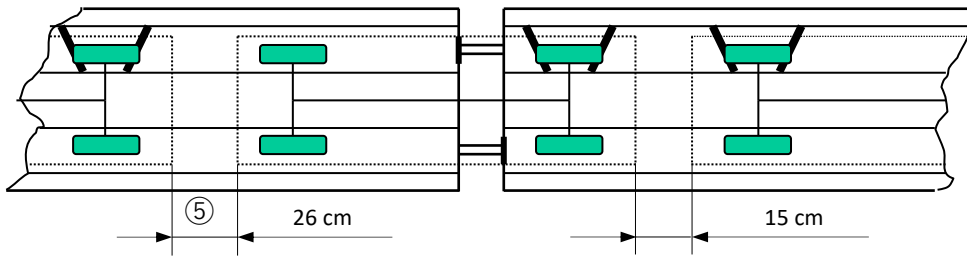

Minimum vertical distance between the vehicle roof and the upper deck of the wagon: 8 cm

### Securing

Lengthways in the wagon,

- vehicles should be secured by two scotches on a single wheel
- vehicles loaded on the inclined part of the lower decks should be secured using four scotches on the same axle.

Crossways in the wagon,

- vehicles should be secured by means of guide rails at least 5 cm high

### Additional indications

Wheel scotches not in use shall be suitably secured

Load of wagons: see information sheet 0.1

Maximum dimensions of loads: see information sheet 0.2

## Chapter 8: Boats



## 8.1 Boats weighing up to 500 kg

Single wagons and groups of wagons

Wagons in block trains or combined transport  
Wagons with long-stroke shock absorbers

### Type of goods

Boats weighing up to 500 kg.

### Wagons

Wagons with walls, sides or stanchions and a wooden floor

### Method of loading

Boats should be loaded on

- ① - cradles,
- ② - two metal or wooden chocks adapted to the shape and weight of the boat
- ③ Insert protective padding as shown.

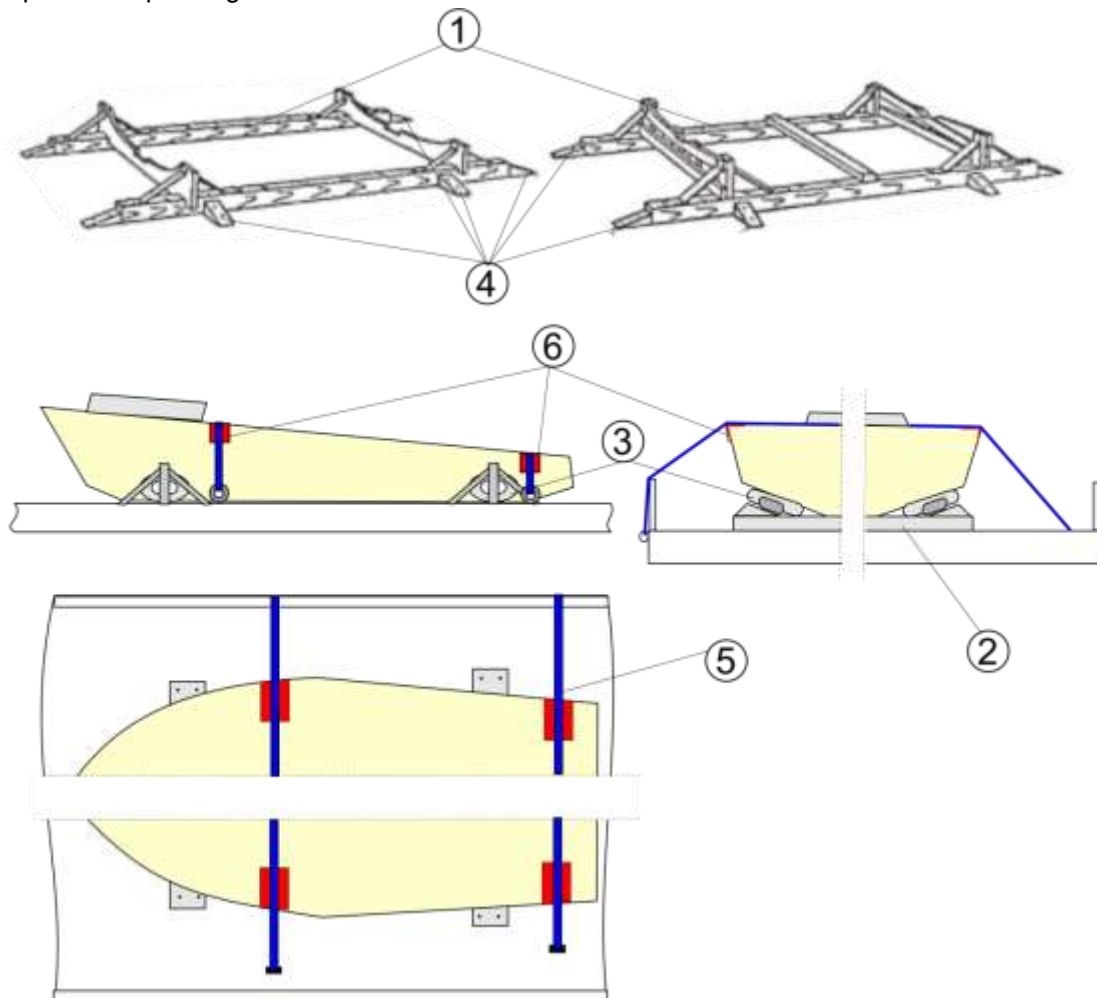

### Securing

- ④ Cradles or chocks should be scotched to the wagon lengthways and crossways.
- ⑤ Boats should be indirectly fastened with ropes or straps (breaking strength at least 1000 daN).
- ⑥ Protective padding should be inserted where the fastenings are in contact with the boat.

### Additional indications

Load of wagons: see information sheet 0.1,  
Single-use bindings<sup>1)</sup> see information sheet 0.6,  
Indirect fastenings<sup>1)</sup> siehe Verladeinformation 0.7.

<sup>1)</sup> The minimum breaking strength (straight pull) corresponds to double the permitted tensile force (LC); this concerns only synthetic straps, woven straps and load securing straps, as well as lashing steel wire ropes and lashing chains.



## 8.2 Boats weighing over 500 kg

Single wagons and groups of wagons

Wagons in block trains and combined transport  
Wagons with long-stroke shock absorbers

### Type of goods

Boats weighing over 500 kg

### Wagons

Wagons with walls, sides or stanchions and a wooden floor

### Method of loading

- ① Boats should be loaded onto metal or wooden cradles adapted to the shape and weight of the boat.
- ② At least 1 m end clearance.

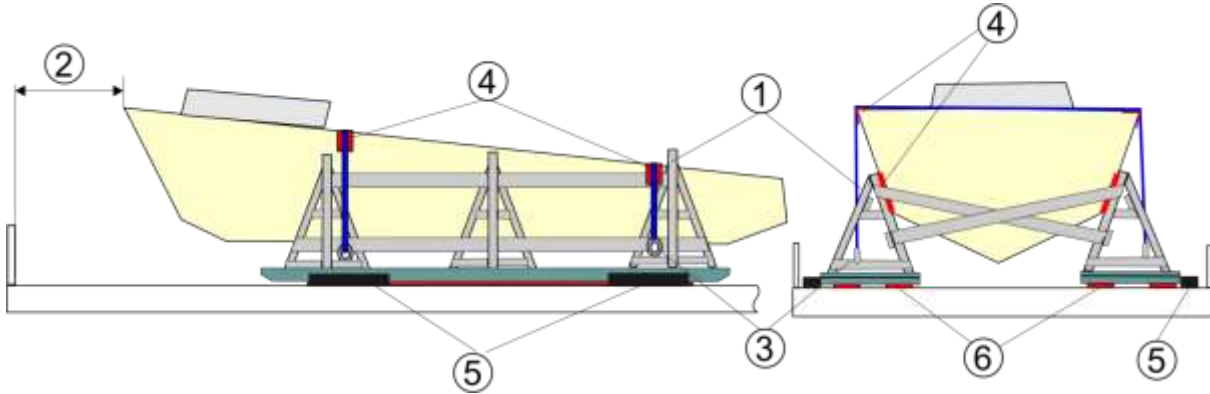

### Securing

- ③ Boats should be secured to cradles with straps or ropes (breaking strength at least 1000 daN).
- ④ Protective padding should be inserted where the binding is in contact with the boat.
- ⑤ Lateral guide-pieces with an effective height of at least 3 cm. Guide-pieces should be fastened on each side with one 5 mm diameter approx., nail per 1500 kg of load and at least, two nails per guide-piece.
- ⑥ Cradles should be placed on friction strips (e.g., granulated composite rubber matting)

### Additional indications

Load of wagons: see information sheet 0.1

Single-use bindings<sup>1)</sup> see information sheet 0.6,

Indirect fastenings<sup>1)</sup>: see information sheet 0.7

Friction and coefficients of friction: see information sheet 0.8.

<sup>1)</sup> The minimum breaking strength (straight pull) corresponds to double the permitted tensile force (LC); this concerns only synthetic straps, woven straps and load securing straps, as well as lashing steel wire ropes and lashing chains.



### 8.3 Boats on trailers

Single wagons and groups of wagons

Wagons in block trains or combined transport  
Wagons with long-stroke shock absorbers

#### Type of goods

Boats on trailers

#### Wagons

Wagons with sides or stanchions and wooden floor

#### Method of loading

- ① The boat should be firmly secured to the trailer.
- ② Trailer and towing vehicle should be coupled.

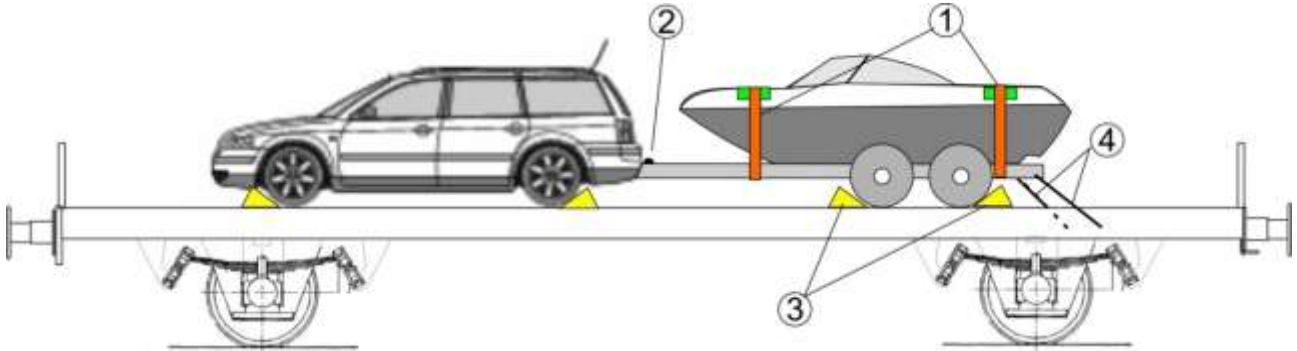

#### Securing

- ③ The trailer should be scotched in each rolling direction (scotch height at least 12 cm, at least two nails per scotch).
- ④ Trailer lashed firmly to the wagon (breaking strength 1000 daN).

#### Additional indications

Load of wagons: see information sheet 0.1

Single-use bindings<sup>1)</sup> see information sheet 0.6,

Indirect fastenings<sup>1)</sup>: see information sheet 0.7

<sup>1)</sup> The minimum breaking strength (straight pull) corresponds to double the permitted tensile force (LC); this concerns only synthetic straps, woven straps and load securing straps, as well as lashing steel wire ropes and lashing chains.



## **Chapter 9: Combined transport load units**



## 9.0 Combined transport - General

### Principles applicable to combined transport (CT)

CT involves carriage of coded intermodal transport units (ITUs) on special carrier wagons running in trains subject to an agreement; these trains have a maximum profile number and run on approved lines subject to a special examination.

#### Intermodal transport units (ITUs) shall be:

- containers (Cts) whose dimensions, corner fittings and strength are standardised by the International Standardisation Organisation (ISO)
- swap bodies (SBs), special swap bodies, demountable bodies (DBs), heavy-duty swap bodies and semi-trailers (STs).

These ITUs must comply with the legal prescriptions and technical provisions in force in every case (e.g. ISO, EN standards, UIC leaflets, International Railway Solutions (IRS), CSC, ACEP) and bear the relevant markings.

ITUs must be approved, fit for transport, safe in operations and suited to the load they are carrying.

The owner, keeper or a proxy is responsible for maintaining the ITU and overseeing the inspections. If any changes are made to the design, further official approval is required.

#### Marking:

- on SBs, special swap bodies, DBs, heavy-duty swap bodies and STs by means of a yellow code number plate (officially approved internationally and UIC-compliant) fitted on either side of each unit. Alternatively, SBs and STs may be marked by yellow code number plates compliant with EN 13044 with separate indications to identify the owner by means of an ILU (Intermodal Loading Unit) code or BIC code (ownership code).
- on SBs, special swap bodies, DBs, heavy-duty swap bodies and STs by means of red code number plates (approved at national level but whose characteristics are not all UIC-compliant, accepted through bilateral and multilateral agreements).

RUs accepting these units are mentioned in the relevant example loading, whose number is indicated on the code number plate; in addition, a QR code may be affixed, which refers to the relevant loading example in force.

Examples of possible red code number plates:

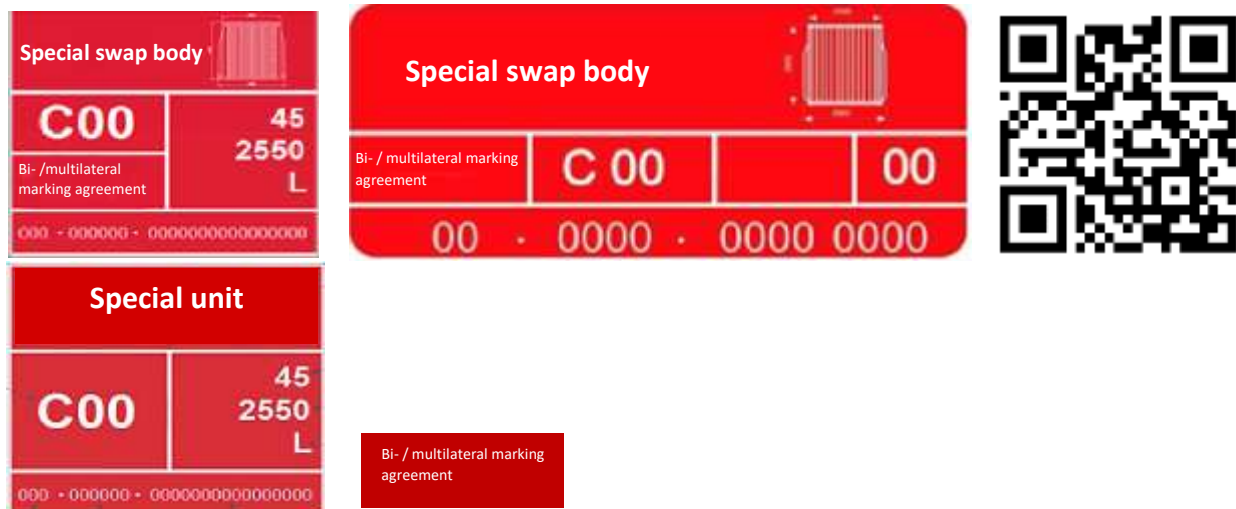

The data on the plate includes the profile code and width according to UIC 596-6 / IRS 50596-6 as well as information on the length category and the number of the bi-/multilateral agreement (Loading example). The code plates may only be issued by authorised bodies (conformity assessment body in accordance with IRS 50596-6, Annex H.1, Table 1).

The following applies to ILUs codified after 1 July 2025: The number of the loading example must be stated next to or on the red code number plate; transport is not permitted without a valid loading example marked on the ILU.

A QR code referring to the relevant loading example in force can be affixed near the red code number plate.

## 9.0

- ISO 668 container with the ownership code (BIC code), serial number, inspection number, dimensions code and type code as well as the indications of height / height and width.  
Note: ISO 668 containers do not have a code number plate, containers listed in loading method 9.2 - table 1 with a width of more than 2438 mm (class 2 and 3) do not have a code number plate if they were built and approved before 2013 according to UIC leaflet 592, version 2010 or UIC leaflet 592-2.
- Load units with upper castings bearing the CSC approval plate.
- Height-adjustable tarpaulin superstructures must be identifiable by means of several code number plates, though only the plate corresponding to the relevant edge height may be visible (tarpaulin window) or marked (marker system).
- For height-adjustable tarpaulin superstructures only one of whose height settings is authorised in rail transport, an unequivocal identification system is required (e.g., correlating coloured stripes).

Example of the corresponding edge height indication in case of height-adjustable ILUs

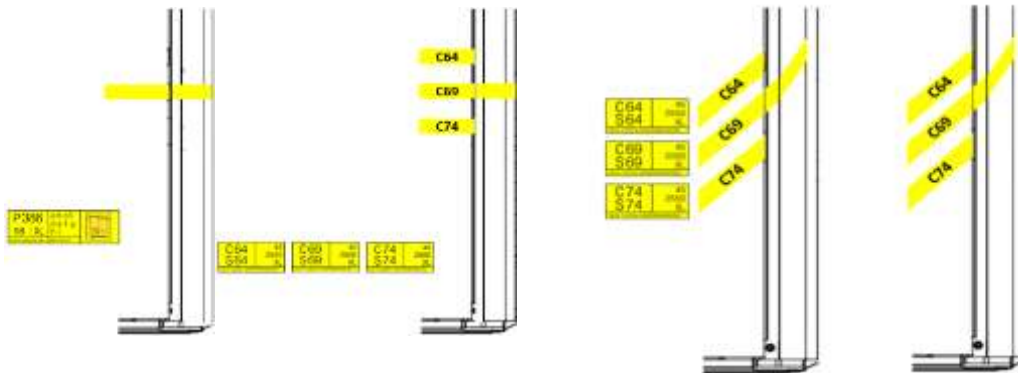

If markings are not in aligned, the adjusted edge height should be matched to the unequivocal combined transport profile.

- ITUs equipped with ladders for access to the danger zone of the high-voltage line must bear the pictogram "**High-voltage warning sign**" in the ladder areas. The pictogram must comply with ISO 6346.

The pictogram consists of a black symbol on a yellow background, surrounded by a black border.

The height of the lightning flash must be at least 175 mm, and the size of the pictogram, measured between the outer edges of the black border, must not be smaller than 230 mm.



ITUs which do not meet these conditions may not be authorised for loading on carrier wagons in combined transport (except for consignments operated in accordance with a loading example).

The load must be secured inside the ITUs in accordance with the UIC Loading Guidelines, by analogy. The sliding method of loading is not permitted inside ITUs. The devices required for transshipment (grab-handling grooves, corner fittings) must be left free.

When loading ITUs, the loading diagrams in force for the relevant carrier wagon must be observed.

### **In principle the following types of wagons are used for combined transport:**

- carrier wagons for containers (Cts), swap bodies (SBs), special swap bodies, and heavy-duty swap bodies
- carrier wagons only for the transport of ISO containers,
- carrier wagons for demountable bodies (DBs),
- carrier wagons for swap body types 1, 2 and 3 (see loading method 9.1.1),
- carrier wagons for semi-trailers and, potentially, Cts, SBs and special swap bodies,
- flat wagons without a compatibility code, under special conditions (see table 1).

The features of the various systems are indicated by means of the following wagon compatibility codes:



Swap bodies on carrier wagons for SBs and Cts,



ISO container on wagon with a bogie pivot pitch (pivot distance > 16,15 up to and including 19,30 m



Demountable bodies (horizontal transshipment) on carrier wagons for demountable bodies,



STs on pocket wagons,



STs on certain pocket wagons, Novatrans system,



STs on bogies, Road Railer system,



STs on bogies, Transtrailer system,



STs on bogies, Kombi Rail system,



STs on certain pocket wagons, Cemat-Technik system (no UIC regulations, only by multilateral agreement),



STs on certain pocket wagons, Alpen-Trailer system (no UIC regulations, only by multilateral agreement),



STs on pocket wagons with broader clearance envelopes (multilateral agreement)

	a	b	c	d	e	f	g	h	i
--	---	---	---	---	---	---	---	---	---

	a	b	c	d	e
	f	g	h	i	

STs on pocket wagons with broader clearance envelopes and compatibility codes.

The loading conditions of different ITUs are defined in the subsequent loading methods, 9.x.

**Line codes**

Railway infrastructure managers (IMs) define maximum CT profiles in force on certain lines, in accordance with IRS 50596-6/UIC Leaflet 596-6. The profiles are identified by means of a wagon compatibility code, e.g. P or C, and a profile number code (normal profile).

Line codes as per P are also applicable for R, T and N; line codes as per C are also applicable for K and B. In Great Britain lines are coded according to the special profile (S).

Line codes are indicated in the conditions of use for the IM's network, along with other information pertaining to network access.

**Profile for the carriage of an ordinary consignment**

The permissible profile for the carriage of an ordinary consignment is based on the code number plate of ITU or table 1 of the loading method 9.2 and, where applicable, the correction digit indicated on the carrier wagon.

This consignment profile should not exceed the values in table 1 of the loading method 9.0. In Great Britain only the special profile (S) is applicable; the conditions in table 2 of the loading method 9.0 should be observed.

**Correction digit**

Carrier wagons with characteristics in accordance with IRS 50596-6/UIC Leaflet 596-6 are indicated by a yellow wagon compatibility code, for example:





and should be additionally marked with correction digit in accordance with Appendix 11 to the GCU.

Examples:

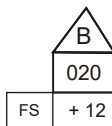

- For wagons with this marking the profile number for the route should be up to 23 units higher for all networks. This also applies to values in table 1 of the loading method 9.0, column entitled "Wagons with compatibility code ". The smallest resulting value of the route gives the consignment profile. The code number of the ITU to be loaded should not exceed this consignment profile



-For wagons with this marking the profile number for the route should be up to 12 units higher for FS network. This also applies to values in table 1 of the loading method 9.0, column entitled "Wagons with compatibility code ". The smallest resulting value of the route gives the consignment profile. The code number of the DB to be loaded should not exceed this consignment profile

Carrier wagons with characteristics **other** than those set out in IRS 50596-6/UIC Leaflet 596-6 are subject to a bilateral or multilateral agreement and should be marked with white correction digit in accordance with Appendix 11 to the GCU.

Carrier wagons have a white compatibility code.

The correction digit on the carrier wagon indicates the value by which the ITU profile for the route should be increased / decreased for the RU/IM indicated to obtain the consignment profile.

Examples



- For wagons with this marking the profile number for the route should be lower by at least 3 units for SNCF and 2 for FS. This also applies to values in table 1 of the loading method 9.0, column entitled "Wagons with compatibility code ". The smallest resulting value of the route gives the consignment profile. The code number of the ITU to be loaded should not exceed this consignment profile

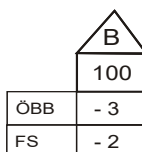



-For wagons with this marking the profile number for the route should be lower by at least 3 units for ÖBB and 2 for FS. This also applies to values in table 1 of the loading method 9.0, column entitled "Wagons with compatibility code ". The smallest resulting value of the route gives the consignment profile. The code number of the DB to be loaded should not exceed this consignment profile.

Table 1

SBs / Cts / DBs may be transported as normal consignments on all the lines of the corresponding IM / RU under CT conditions if

their allocated code number (module number), according to the carrier wagon, is not higher than the profile number concerned.

Country code	RU / IM	Two-axle wagons		Bogie wagons							Wagons with compatibility code		
		K... L...s	L...s	R...s			S...s						
		Distance between axles up to		Distance between bogies up to									
		8 m	9 m	9 m	14.86 m			11.30 m	15.80 m				
		External overhang		Overhang				Overhang					
		max. 2.25 m	max. 2 m	max. 2 m	max. 2 m	max. 2 m	max. 2 m	max. 2 m	max. 2 m	max. 2 m	max. 2 m		
		Height of the loading surface		Height of the loading surface up to					Height of the loading surface up to				
		1250 mm	1180 mm	1260 mm	1180 mm	1240 mm	1260 mm	1300 mm	1180 mm	1180 mm	1240 mm	 	
		Loading tolerance		Loading tolerance				Loading tolerance					
		± 20 mm	± 10 mm	± 10 mm				± 10 mm					
		with lateral guide-pieces	with securing device	with lateral guide-pieces or securing devices				with securing devices					
10 <sup>3)</sup>	VR <sup>3)</sup>												
24	LTG												
41	HSH												
43	GySEV												
44	ZRS												
50	ZFBH	C 25 / C 343	C 32 / C 350	C 24 / C 342	C 22 / C 340	C 16 / C 334	C 14 / C 332	C 10 / C 328	C 32 / C 350	C 22 / C 340	C 16 / C 334	.....	.....
51	PKP PLK												
52	BDZ												
53	CFR												
54	CDC												
55	MAV <sup>4)</sup>	C 21 / C 340	C 32 / C 351	C 24 / C 343	C 19 / C 338	C 13 / C 332	C 11 / C 330	C 07 / C...	C 28 / C 347	C 18 / C 337	C 12 / C 331	C 21 / C 340	B 21 / B 340
56	ZSSKC												
63	BLS	C 19 / C 338	C 26 / C 345	C 15 / C 334	C 24 / C 343	C 18 / C 337	C 16 / C 335	C 12 / C 331	C 25 / C 344	C 24 / C 343	C 12 / C 331	C 25 / C 344	B 25 / B 344
64	FNME												
65	MZ												

## 9.0

70	EWS	.....	.....	.....	.....	.....	.....	.....	.....	.....	.....	See table 2	no
71	ADIF	C 26 / C 345	C 33 / C 352	C 25 / C 344	C 33 / C 352	C 27 / C 346	C 25 / C 344	C 21 / C 340	C 33 / C 352	C 33 / C 352	C 27 / C 346	C 33 / C 352	
72	ZS												
73	TRANOSE												
74	TRAFIKVERKET	C 36 / C 364	C 43 / C 371	C 35 / C 363	C 43 / C 371	C 37 / C 365	C 35 / C 363	C 31 / C 359	C 43 / C 371	C 43 / C 371	C 37 / C 365	C 43 / C 371	<sup>1)</sup>
75	TCDD												
76	JBV	C 69 / C399	C 77 / C407	C 69 / C 399	C73 /C403	C 67 / C397	C 65 / C 395	C 61 / C 399	C 77 / C 407	C 70 / C 400	C 64 / C 394	C 77 / C 407	no
78	HZ	C 25 / C 343	C 32 / C 350	C 24 / C 342	C 22 / C 340	C 18 / C 334	C 14 / C 332	C 10 / C...	C 32 / C 350	C 22 / C 340	C 16 / C 344	.....	.....
79	SZ	C 25 / C337	C 24 / C337	C 25 / C337	C 21 / C335	C 21 / C337	C 14 / C332	C 10 / C...	C 32 / C 350	C 24 / C336	C 21 / C 334	C 21 / C334	B 21 / B 334
80	DB	C 17 / C 336	C 25 / C 344	C 17 / C 336	C 19 / C 338	C 13 / C 332	C 11 / C 330	C 7 / C ...	C 24 / C 343	C 18 / C 337	C 12 / C 331	C 21 / C 340	B 21 / B 340
81	ÖBB	C 17 / C 344	C 26 / C 353	C 20 / C 347	C 19 / C 346	C 13 / C 340	C 11 / C 338	C 7 / C334	C 24 / C 351	C 18 / C 345	C 12 / C 339	C 21 / C 348	B 21 / B 348
82	CFL	C 17 / C 336	C 25 / C 344	C 17 / C 336	C 19 / C 338	C 13 / C 332	C 11 / C 330	C 07 / C ...	C 24 / C 343	C 18 / C 337	C 12 / C 331	C 21 / C 340	B 21 / B 340
83	FS	C 12 / C 331	C 19 / C 338	C 11 / C 330	C 17 / C 336	C 11 / C 330	C 09 / C...	C 05 / C...	C 19 / C 338	C 13 / C 332	C 07 / C...	C 18 / C 337	B 18 / B 337
84	NS	C 17 / C 336	C 25 / C 344	C 17 / C 336	C 19 / C 338	C 13 / C 332	C 11 / C 330	C 07 / C ...	C 24 / C 343	C 18 / C 337	C 12 / C 331	C 21 / C 340	B 21 / B 340
85	SBB/CFF	C 19 / C 338	C 26 / C 345	C 15 / C 334	C 24 / C 343	C 18 / C 337	C 16 / C 335	C 12 / C 331	C 25 / C 344	C 24 / C 343	C 12 / C 331	C 25 / C 344	B 25 / B 344
86	DK	C 32 / C 356	C 43 / C 366	C 35 / C 358	C 43 / C 366	C 37 / C 360	C 35 / C 358	C 31 / C 354	C 43 / C 366	C 43 / C 366	C 37 / C 360	C 45 / C 369	B 45 / B 369
87 <sup>2)</sup>	SNCF (WB)	C 11 / C 330	C 20 / C 339	C 12 / C 331	C 11 / C 330	C 05 / C ...	C 03 / C ...	C .. / C ...	C 20 / C 339	C 09 / C ...	C 03 / C ...	C 22 / C 341	B 22 / B 341
	(Ct)	Module 3		Module 3	Module 3					Module 3	Module 3		
88	B	C 22 / C 344	C 30 / C 352	C 22 / C 344	C 30 / C 352	C 24 / C 346	C 22 / C 344	C18 / C 340	C 30 / C 352	C 30 / C 352	C 24 / C 346	C 30 / C 352	B 30 / B 352
94	CP												
96	RAI												
97	CFS												
99	IRR												

<sup>1)</sup> Transport on the basis of the system agreement only as an exceptional consignment in accordance with UIC Leaflet 502-1

<sup>2)</sup> Except for stations mentioned in Section 1, Table 1<sub>2</sub> of the UIC Loading Guidelines (Ct height module: see Loading method 9.2, Table 1).

<sup>3)</sup> Profiles C 99 / C 429 apply to wagons available in traffic involving VR.

<sup>4)</sup> Except for Budapest-Deli Pu station.

**Conditions for accepting ISO containers and special S-profile swap bodies in Great Britain via Dollands Moor**

Type of wagon	Height of the loading surface (mm)	Maximum authorised dimensions for ITUs			
		Maximum width of the swap body			ISO container
		2500	2501-2550	2551-2600	
Sfgmmnss <sup>1)</sup>	475				9'6''
Sffgmrss <sup>1)</sup>	825	S 44	S 44		9'6''
Sfgmrss <sup>1)</sup> Sfgmss <sup>1)</sup>	945	S 32	S 32	S 360	9'0''
Sfgmrss <sup>2)</sup> Sfgmss <sup>2)</sup>	945	S 15			8'6''
Sffgns <sup>3)</sup>	1090	S 21	S 14		8'9''
Sffgns <sup>4)</sup>	1090	S 16	S 14		8'6''
Sfgss <sup>1)</sup>	1100	S 15	S 13		8'6''
Lfgss <sup>5)</sup>	1180	S 11			

To the following stations:

- 1) Birmingham Lawley Street, Crewe Basford Hall, Daventry Rail Port, Doncaster Rail Port, Hams Hall Rail Freight Terminal, Liverpool Seaforth Container Terminal, Manchester (Trafford Park) Euroterminal, Mossend Euroterminal, Wakefield Euroterminal
- 2) Dalry Roche
- 3) Dagenham Ford, Daventry Rail Port, Hams Hall Rail Freight Terminal, London Willesden Euroterminal, Manchester (Trafford Park) Euroterminal, Mossend Euroterminal, Widnes Ahc
- 4) Birmingham Lawley Street, Crewe Basford Hall, Doncaster Rail Port, Liverpool Seaforth, Wakefield Euroterminal
- 5) Dagenham Ford only for Transfesa swap bodies numbered TF001-TF480

**Table 3**

**Fastening to prevent tipping/falling as a result of wind**

Type of line	Wagons	
	with fixing spigots in accordance with IRS 50571-4 <sup>3)</sup>	without fixing spigots
Lines with moderate winds (= all lines)	No specific measures required	800 kg / 3m length <sup>1)</sup> : stanchions <b>and</b> bindings <sup>2)</sup> ≤ 1200 kg / 3 m length <sup>1)</sup> = stanchions <b>or</b> bindings <sup>2)</sup>
Lines with heavy winds (= lines in accordance with table 4).		≤ 1200 kg / 3 m length <sup>1)</sup> = stanchions <b>and</b> bindings <sup>2)</sup>

1) If necessary, the tare of the SB can be found in the carriage documents.

2) Breaking strength (straight pull): 1400 daN minimum.

3) Wagons with inward folding spigots which do not comply with IRS 50571-4 must be treated as if they are without spigots.

List of lines with heavy winds<sup>4)</sup>

UIC Code	EF/IM	Line			Remarks
		from	to	via	
71	ADIF	PORTBOU	VALENCIA		
		VALENCIA	ALCÁZAR DE SAN JUAN		
		BOBADILLA	ALGECIRAS		
		BARCELONA	FIGUERES - VILAFANT / LÍMITE ADIF- LFP, S.A.		
83	FS	PAOLA	S. LUCIDO		
		BIVIO S. SUCIA	SARNO		
		MONFALCONE	TRIESTE.C.LE		
		BIVIO D'AURISINA	VILLA OPICINA		
87	SNCF	AVIGNON	CARPENTRAS		
		AVIGNON	FOS	MIRAMAS	
		AVIGNON	MARSEILLE	ROGNAS or PORT DE BOUC	
		AVIGNON	NARBONNE	NIMES, MONTPELLIER, SETE	
		ELNE BOULOU - MARSEILLE	PERTHUS CARNOULES		
		NARBONNE	PORT BOU	PERPIGNAN	

<sup>4)</sup> Lines in the table are for information purposes only and are not exhaustive. To find out whether a route includes a line exposed to the wind, the relevant information can be obtained from the relevant IM.

## 9.0.1 Securing of goods inside Intermodal Loading Units (ILUs)

### Type of goods

Goods loaded in intermodal transport units

### Stresses during transit/ relevant accelerations

Securing in	Acceleration values				
	$c_x$ , longitudinal		$c_y$ , transverse	$c_z$ , Minimum value vertically downwards	
	slipping	tilting		slipping	tilting
longitudinal direction	1.0	0.6	---	1.0	1.0
transverse direction	---	---	0.5	0.7	1.0

Source: EN 12195-1, table 3

### Stresses during transit/ relevant accelerations

- ① in the longitudinal direction (forwards and backwards): up to 1 g ( $g = 9.81 \text{ m/s}^2$ )
- ② in the transverse direction: up to 0.5 g
- ③ Vertical stresses make the goods more likely to move about during transit.

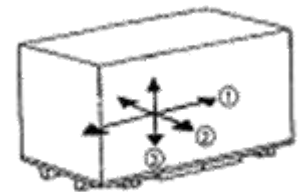

### Condition of ILUs used for transport

- floor clean,
- side walls, floor, solebars, laths and tarpaulins in one piece and in good condition,
- the belt buckles of the sliding tarpaulins must always be correctly fitted and tensioned.
- doors and walls must close properly,
- in securing the load, bindings must not be attached to the corner fittings or grab-handling grooves of the ILU.
- for foldable ILUs, all locking devices/locks should be placed into active position in accordance with the manufacturer's operating instructions.
- tarpaulins must not be secured with elasticated straps (e.g. elasticated zigzag cords).

### Method of loading and load securing

According to applicable regulations for load securing in combined transport such as e.g., EN 12195, etc

- distribute bulk goods evenly and compactly across the loading surface,
- no sliding load is permitted
- do not exceed the outer dimensions of the ILU<sup>1)</sup>,
- distribute load evenly,
- stacking is permitted only if the lower tier covers the entire loading surface and offers a suitable bearing surface.
- neither the goods nor the method of loading must place a stress on the ILU such as to constitute an operating risk.
- Coils or goods providing concentrated loads should only be transported in loading units dedicated or equipped for this purpose.

<sup>1)</sup> Any derogation must be agreed with all participants in the transport (RU, combined transport operators, terminal operators, etc.)

## 9.0.1

### Securing

To ensure load stability, identical items or piles are to be bound together using e.g. bindings or shrink-fit or stretch-wrapped films or covers. Bags must be cross-stacked or be inclined inwards.

Any goods which may blow away in the wind must be protected against falling/blowing off.

Goods not propped against the side walls or longitudinal walls must be held in place by, for example:

- direct or indirect fastenings,
- supporting struts,
- air cushions/padding,
- pallets or boards in vertical position,
- inserts made from friction-enhancing material.

Preferably, securing devices built into the load units are to be used.

The supporting struts must be arranged such that pressure from the load is spread across as large a surface as possible. They must support the full width of the load as far as the front doors and end walls, and if possible, against the corner posts.

To secure by using tarpaulins, bent frames, solebars or laths is only permissible for particular tarpaulin models. These tarpaulins must be identified by the following pictogram on the front side or next to the number code plate.

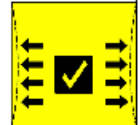

To be secured against tipping goods are held in place if ratio of their loading surface to their height (h) is not equal at least to

- $\frac{6}{10}$  in the longitudinal direction,
- $\frac{5}{10}$  in the transverse direction of the height

by a frame, stanchions or bindings placed on approximately  $\frac{3}{4}$  of their height

The goods of cylindrical forms must be held in place to prevent their rolling.

## 9.1 Swap bodies (SBs)

Single wagons and groups of wagons (for conveyance conditions see loading method 9.0)

Wagons in block trains or combined transport  
Wagons with long-stroke shock absorbers

### Type of goods

a) Swap bodies (SBs) with UIC code number plate

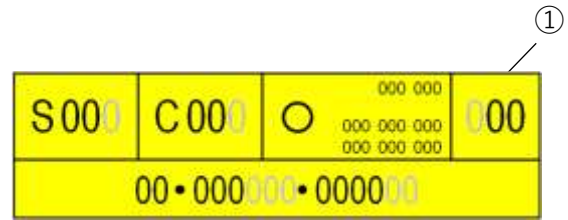

- SBs with a width of 2550 mm are identified by the following additional plate placed in or next to the UIC code number plate.



SBs with sheeting suitable for transport on trains running at over 120 km/h must be compliant with EN 12642 (Code XL) and bear "XL" marking on the code number plate or additional plate



b) SBs with code number plate in accordance with EN 13044

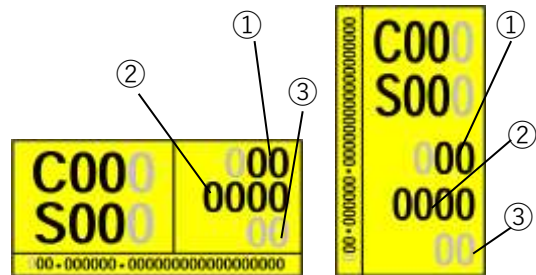

① The SB is allocated a length code on the basis of the distance between the centres of its corner fittings, its external length and its overhangs. The length code must be observed when positioning the SB on the carrier wagon, taking into account the relevant loading diagram.

② indicates the width category of the SB.

③ indicates the strength of the SB structure, the indication XL (XL code) meets the requirements of EN 12642 and should be present for transport on trains running at over 120 km/h.

The profile number on the code number plate indicates that

- the SB does not exceed a set width:
  - C000 = maximum width of 2550 mm,
  - C0000 = width higher than 2550 mm up to a maximum of 2600 mm,
- the edges height and roof shape do not exceed a gauge profile set by UIC.

④ Characterises the strength of tarpaulins permitted for the transport of loads subject to settling.

- Goods loaded in accordance with the applicable load certificate can touch the tarpaulin (e.g. car tyres with load certificate, etc.)
- Good and securing methods can not come into sharp edge contact with the tarpaulin or damage it.
- The SB does not exceed the maximum width in accordance with the code number plate.
- These SBs are allowed to be transported up to 140 km/h

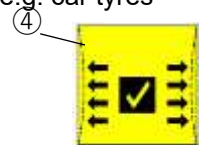

Swap bodies with upper castings shall, in addition, bear a valid CSC approval plate.

The date of the next overhaul must be indicated on the CSC approval plate or next to it.

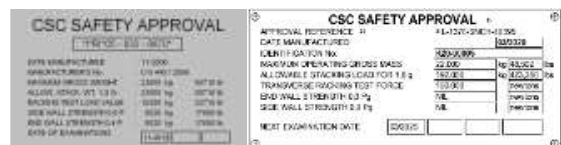

Example : current

Example : new

Load units with an ACEP marking should be monitored permanently.

The date of the next overhaul is not indicated.

The marking of the approval authority must be present.



## 9.1

The grab-handling grooves must be in perfect condition, and to prevent longitudinal movement of the grab handles they must have a stop at a distance of 500 mm on each side or, depending on the design (e.g. with legs), be at a minimum distance of 850 mm from the axis of the casting.

Their position must be indicated by means of a yellow or contrasting band measuring approx. 100 mm-high placed above them. Any sheeting protection plates placed above the grab-handling grooves must not project above the surface of the grab-handling groove stops. They must not be bent or detached.

- They must also be indicated by coloured marking.  
Sliding sheeting (curtainsider) must not encroach into the area where the grab-handling grooves are located.
- The legs must be folded up, locked and secured by means of a ratchet.

### Wagons

a) Carrier wagons of combined transport with

- a compatibility code  **and** where necessary an additional plate with positive correction digit



Ex. +23 applicable on all coded lines

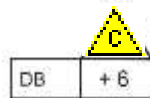

Ex. +6 applicable only on DB Netz coded lines.

or

- a plate  with correction digit (in accordance with bi-/multilateral agreement)

Compatibility code and correction number line applicable only on the coded lines of the networks indicated.

	
1000	-3
15	-2
100 1000 40 1000	0



b) Flat wagons with spigots<sup>1)</sup>

c) Flat wagons with wooden floors<sup>1)</sup>

### Method of loading

- The SB must rest on four castings.
- On swap bodies with more than four castings on the lower part, the castings to be used for rail transport are indicated by yellow or red triangles pointing downwards or by painting castings in a contrasting colour. If there are no markings, for consignment it is advisable to use the castings located under the supporting column.
- Any spigots or twist-locks placed under the SB and not required for use are folded down or away and secured in that position.
- When loading on carrier wagons with inward folding spigots that do not have a safety mechanism against folding, additional safety measures must be taken to prevent the ILU from tipping over during windy conditions.
- SBs, special swap bodies, and Cts must rest flat on four castings. A tolerance on one casting of up to 10mm between the base of the spigot and the lower part of the corner fitting/piece in a vertical direction is permitted. The underside of the spigot head must be engaged.
- The wagon loading diagram must be complied with; an ILU must not be loaded above the centre bogie or the buffing and draw gear.

Special provisions for loading on pocket wagons:

- SBs up to 40 feet in length with or without CSC approval plate may be loaded on all pocket wagons.
- SBs up to 40 feet in length with pictogram  and/or a CSC approval plate may be loaded on all pocket wagons.
- SBs with the pictogram  may be conveyed on pocket wagons if the intermediate timbers or rolling beams on the solebar are brought into the active position.

<sup>1)</sup> If the profile data resulting from loading method 9.0 table 1 is exceeded, these consignments may only be transported as exceptional consignments.

- SBs with the pictogram  may not be conveyed on pocket wagons.
- When loading SBs with group numbers 40 to 53 and 91 to 98 without CSC approval plate, the intermediate timbers or rolling beams on the solebar should be placed into active position.



Meaning: plate for swap bodies wider than 2500 mm but with a setback of 2500 mm in the area of fixing pieces.

NB: not all swap bodies carry this plate, even if this parameter is respected.

- Intermediate supports, if present, should be placed into active position.

### Securing

- Using spigots or turn-screws on wagons as per a) and b).  
Corner fittings incorporated into the legs must not be used to secure the SB on the carrier wagon.
- Using fixed lateral guide-pieces or wooden guide-pieces on the wagon as per c):
  - for SBs with a bottom frame: min. 30x5x5 cm,
  - for SB without a bottom frame: min. 100x5x5 cm.
 The wooden pieces are to be fixed by means of a nail ( $\varnothing$  approx. 5 mm) per 1500 kg of load mass and with at least two nails per wooden piece.

SBs loaded one on top of the other may only be carried on carrier wagons for combined transport within the loading gauge if they are of the same type, of the same length and connected or screwed together by four intermediate timbers<sup>2)</sup> with twist locks of the same type at their corner pieces.

- In the case of automatic or semi-automatic locking systems, the locked position should be visible.
- In the case of manual locking systems, the locking lever in the locked position should be secured in such a way that spontaneous or unintentional unlocking is impossible.
- When using bindings<sup>2)</sup> without twist locks, loaded SBs stacked on top of each other should be bound together with at least two bindings<sup>3)</sup> with edge protection on sharp edges. Bindings that should be used for this purpose are woven and synthetic straps.
- Any covering surfaces must be secured on both sides to prevent them from being blown away during transport.
- To prevent SBs tipping or falling from the wagon as a result of wind, they should be firmly secured as specified in loading method 9.0, tables 3 and 4.

### Additional indications

General indications: see loading methods 9.0 and 9.0.1,

Load of wagons: see information sheets 0.1 and 0.4,

Maximum dimensions of loads: see information sheet 0.2,

Covering of loads: see information sheet 0.3.

<sup>2)</sup> The dimensions of the connecting pieces must correspond to the stresses resulting from the dynamic effects produced during carriage by rail.

<sup>3)</sup> Tensile breaking strength of bindings (straight pull): 1400 daN minimum



### 9.1.1 Swap bodies dedicated to certain carrier wagons

Single wagons and groups of wagons (for conveyance conditions see loading method 9.0)

Wagons in block trains or combined transport  
Wagons with long-stroke shock absorbers

#### Type of goods

- Swap bodies (SBs) checked in accordance with an approval procedure, marked and dedicated to specific carrier wagons.
- Code number plates for SBs

a) type 1:

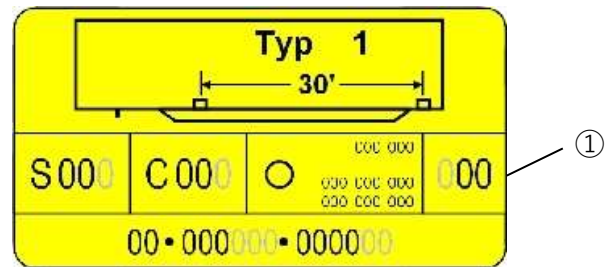

b) type 2:

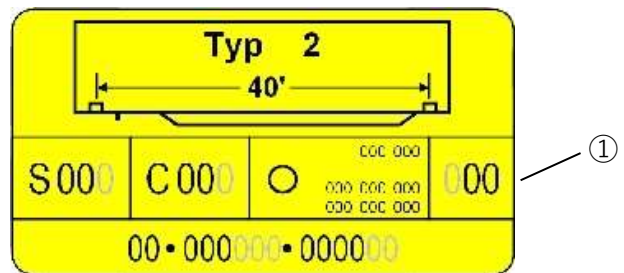

c) type 3:

On various couplings of two-axle carrier wagons, it is possible to use two different bearing heights according to the positions of the foldable locks.

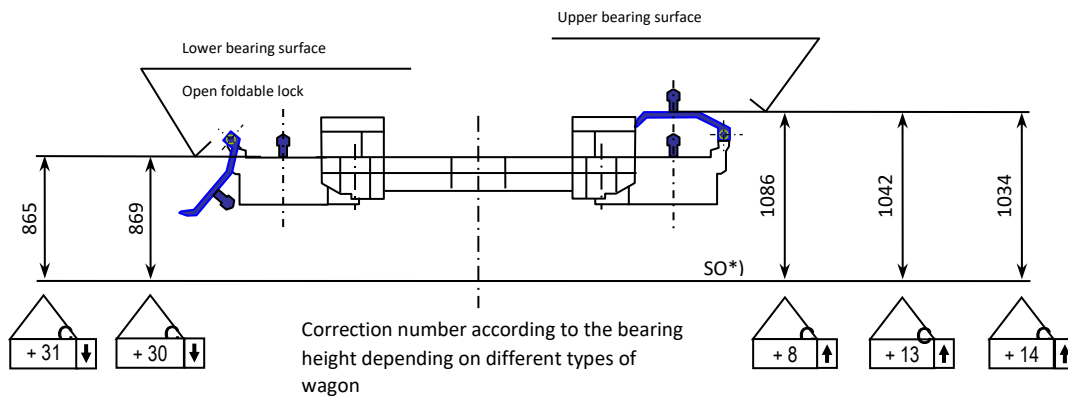

\*) SO = railhead

On the upper bearing surface, SBs may be loaded as per loading method 9.1.

On the lower bearing surface, type 3 SB with code number plate.

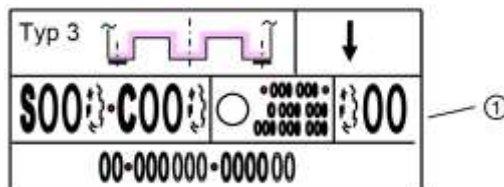

① The SB is allocated a length code on the basis of the distance between the centres of its corner fittings, its external length and its overhangs. The length code must be observed when positioning the SB on the carrier wagon, taking into account the relevant loading diagram.

### 9.1.1

- The profile number on the code number plates means that
  - the SB does not exceed a set width
    - C00 = maximum width of 2550 mm
    - C000 = width higher than 2550 up to a maximum of 2600 mm
  - the edges height and the roof shape do not exceed a gauge profile set by UIC.
- The grab-handling grooves must be in perfect condition, and to prevent longitudinal movement of the grab handles they must have a stop at a distance of 500 mm on each side or, depending on the design (e.g. with legs), be at a minimum distance of 850 mm from the axis of the casting. Their position must be indicated by means of a yellow or contrasting band measuring approx. 100 mm-high placed above them. Any sheeting protection plates placed above the grab-handling grooves must not project above the surface of the grab-handling groove stops. They must not be bent or detached. They must also be indicated by coloured marking.
- Sliding sheeting (curtain) must not encroach into the area where the grab-handling grooves are located.
- The legs must be folded up, locked and secured by means of a ratchet.

### Wagons

a) Carrier wagons with identification plate for the transport of type 1 SBs:

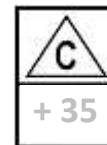
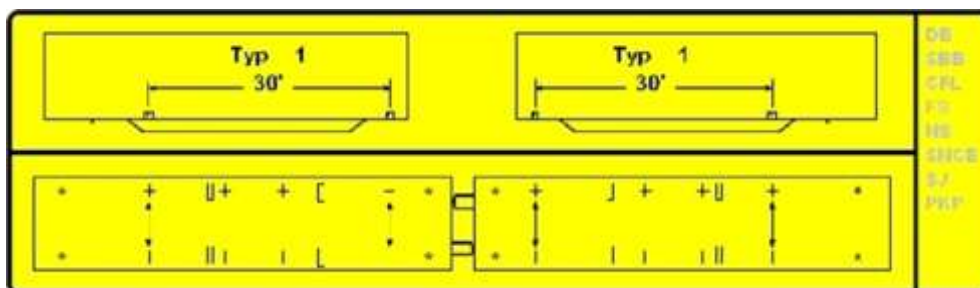

and additional marking of the carrier wagons with the wagon compatibility code:

b) Carrier wagons with identification plate for the transport of type 2 SBs:

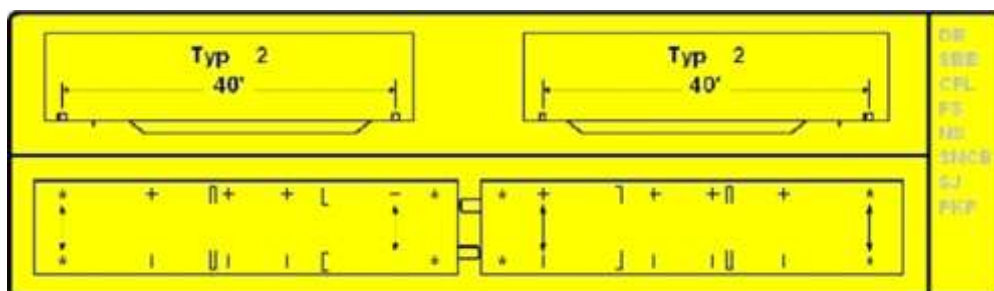

and additional marking of the carrier wagons with the wagon compatibility code:

c) Carrier wagons with identification plates:

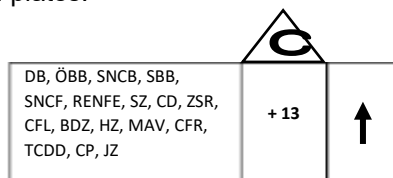

On the upper bearing surface (closed foldable locks) it is possible to load SBs in accordance with loading method 9.1. In the presence of the  $\uparrow$  sign, it is obligatory to use the upper bearing surface.

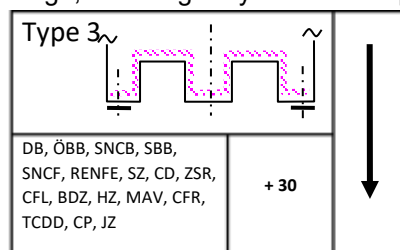

On the lower bearing surface (open foldable locks) the design only permits loading of type 3 swap bodies. In the presence of the  $\downarrow$  sign, it is obligatory to use the lower bearing surface.

### Method of loading

- The carrier wagons must be suitable for transporting the SBs described and marked accordingly.
- The type of number on the SB must match the carrier wagon's type number.
- Transport is based on multilateral agreements. RUs/networks taking part in transport must be indicated on the identification plate of the wagon.
- The relevant spigots should be placed into active position and in contact with all four castings.
- If the SBs are asymmetric, the direction of loading must be taken into account.
- When loading on carrier wagons with inward folding spigots that do not have a safety mechanism against folding, additional safety measures must be taken to prevent the ILU from tipping over during windy conditions.

### Securing

- Using spigots.
- Corner fittings incorporated into the legs must not be used to secure the SB on the carrier wagon.
- To prevent SBs tipping or falling from the wagon as a result of wind, they should be firmly secured as specified in loading method 9.0, tables 3 and 4.

### Additional indications

General indications: see loading methods 9.0 and 9.0.1,

Load of wagons: see information sheet 0.1

Maximum dimensions of loads: see information sheet 0.2,

Covering of loads: see information sheet 0.3,

Bulk goods: see information sheet 0.4.



### 9.1.2 Special swap bodies

Single wagons and groups of wagons (for conveyance conditions see loading method 9.0)

Wagons in block trains or combined transport  
Wagons with long-stroke shock absorbers

#### Type of goods

Special swap bodies are swap bodies with a base width higher than 2600 mm.

The lower area of these load units is wider than CT profiles, while observing the international loading gauge in accordance with table 1<sub>1</sub> of volume 1 of the Loading Guidelines.

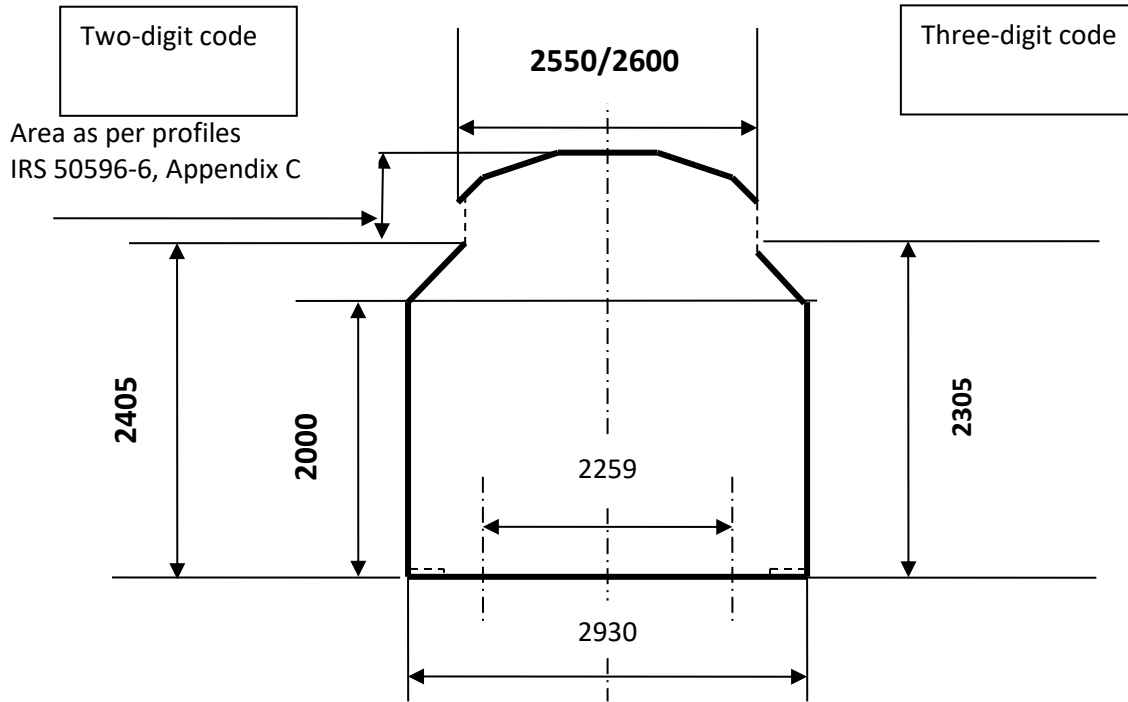

With code number plate and additional pictogram:

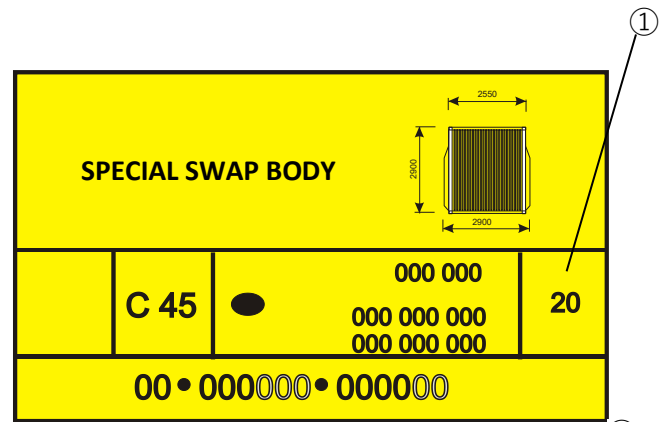

or

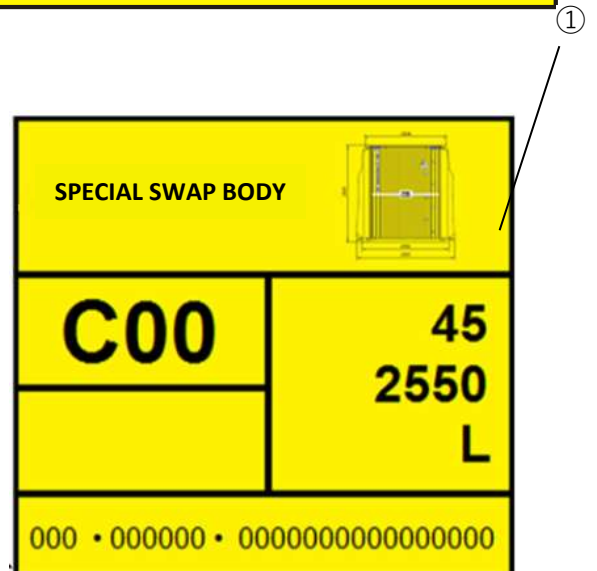

### 9.1.2

The profile number on the code number plate means that

- the special swap body does not exceed a set width
  - C00 = area according to profile compliant with IRS 50596-6, max. width of 2550 mm,
  - C000 = area according to profile compliant with IRS 50596-6, width greater than 2550 mm, up to a maximum of 2600 mm,
- the edges height and the roof shape do not exceed a gauge profile set by UIC.

- ① The special swap body is allocated a length code on the basis of the distance between the centres of its corner fittings, its external length and its overhangs. The length code must be observed when positioning the special swap body on the carrier wagon.

Special swap bodies with upper castings must, in addition, bear a valid CSC approval plate, taking into account the relevant loading diagram.

The date of the next overhaul must be indicated on the CSC approval plate or next to it.



Example: current



Example: new

Loading units with an ACEP marking should be monitored permanently.

The date of the next overhaul is not indicated.

The marking of the approval authority must be present.

The legs must be folded up, locked and secured by means of a ratchet.

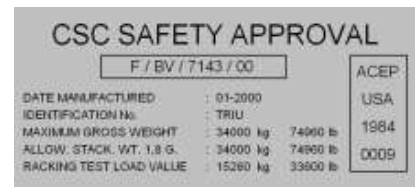

Special swap bodies with reinforced tarpaulins for the transport of loads subject to settlement should be provided with an additional plate on the front wall or next to the code number plate

- Goods loaded in accordance with the applicable load certificate can touch the tarpaulin (e.g. car tyres with load certificate, etc.)
- Good and securing methods can not come into sharp edge contact with the tarpaulin or damage it.
- Special swap body does not exceed the maximum width in accordance with the code number plate.
- These SBs are allowed to be transported up to 140 km/h



### Wagons

Carrier wagons of combined transport with

- a compatibility code  and where necessary an additional plate with positive correction digit



Ex. +23 applicable on all coded lines

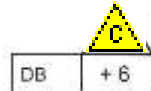



Ex. +6 applicable only on DB Netz coded lines.

## Method of loading

- The special swap body rest on four castings.
- On special swap bodies with more than four castings on the lower part, the castings to be used for rail transport are indicated by yellow or red triangles pointing downwards or by painting castings in a contrasting colour. If there are no markings, for consignment it is advisable to use the castings located under the supporting column.
- Any spigots or twist-locks placed under the special swap body and not required for use are folded down or away and secured in that position.
- When loading on carrier wagons with inward folding spigots that do not have a safety mechanism against folding, additional safety measures must be taken to prevent the ILU from tipping over during windy conditions.
- SBs, special swap bodies and Cts must rest flat on four castings. A tolerance on one casting of up to 10mm between the base of the spigot and the lower part of the corner fitting/piece in a vertical direction is permitted. The underside of the spigot head must be engaged.
- The wagon loading diagram must be complied with; an ILU must not be loaded above the centre bogie or the buffing and draw gear.

Special provisions for loading on pocket wagons:

- Special swap bodies up to 40 feet in length with or without CSC approval plate may be loaded on all pocket wagons
- Special swap bodies up to 40 feet in length with pictogram  and/or a CSC approval plate may be loaded on all pocket wagons
- Special swap bodies with the pictogram  may be conveyed on pocket wagons if the intermediate timbers or rolling beams on the solebar should be placed into active position.
- Special swap bodies with the pictogram  may not be conveyed on pocket wagons.
- When loading special swap bodies with group numbers 40 to 53 and 91 to 98 without CSC approval plate, the intermediate timbers or rolling beams on the solebar should be placed into active position.



Meaning: plate for special swap bodies wider than 2500 mm but with a setback of 2500 mm in the area of fixing pieces.

NB: not all special swap bodies carry this plate, even if this parameter is respected

- Intermediate timbers, if present, should be placed into active position.

## Securing

- Using spigots.
- Corner fittings incorporated into the legs must not be used to secure the SB on the carrier wagon.
- Any covering surfaces (roofs, covers, bonnets, etc.) must be secured on both sides to prevent them being swept away by the wind during transport.
- To prevent tipping or falling of special swap body from the wagon as a result of wind, they should be firmly secured as specified in loading method 9.0, tables 3 and 4.

## Additional indications

General indications: see loading methods 9.0 and 9.0.1,

Load of wagons: see information sheet 0.1

Maximum dimensions of loads: see information sheet 0.2,

Covering of loads: see information sheet 0.3.

Bulk goods: see information sheet 0.4

The transport of special swap bodies with a base width > 2600 mm to Great Britain and Iran is not permitted.



### 9.1.3 Flats

Single wagons and groups of wagons

Wagons in block trains or combined transport  
Wagons with long-stroke shock absorbers

#### Type of goods

Flats loaded individually or stacked:

- a) with end walls and/or raised stanchions and UIC code number plate

The profile number on the code number plate means that

- the flat does not exceed a defined width:
  - C00 = area according to profile compliant with IRS 50596-6, max. width 2550 mm,
  - C000 = area according to profile compliant with IRS 50596-6, width greater than 2550 mm and not greater than 2 600 mm max.,

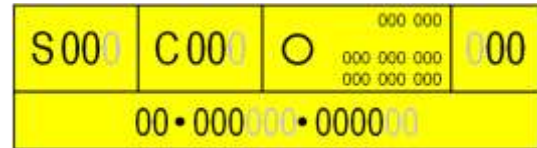

- b) ISO flat containers (lower container)  
to be marked and loaded in accordance with loading method 9.2,

- c) without end walls:  
with identification plate (no indication of code number).

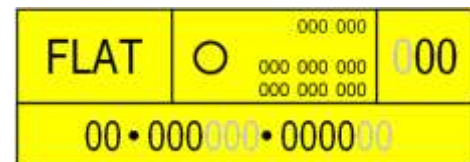

- Flat containers without end walls and/or side walls shall not receive code number plates, only identification plates bearing the word "FLAT" and no permitted CT profile number (code). Loads must therefore be measured prior to carriage and may not foul the applicable loading gauge of the RUs involved on the route taken. No association with CT profiles is permitted.
- Loads on flat containers with a UIC code number plate which exceed the height of the end walls and/or raised stanchions must be measured prior to carriage and may not foul the applicable loading gauge of the RUs involved on the route taken.  
The profile number on the UIC code number plate must be hidden. Association with CT profiles is not permitted.
- Stacked flats must be measured prior to carriage and may not foul the applicable loading gauge of the RUs involved on the route taken.  
Except for block trains, no reference to combined transport profiles is permitted<sup>1)</sup>.

<sup>1)</sup> Where goods are moved by block train in combined transport, the maximum CT-profile of the **used** line to be taken may not be exceeded (**loading method 9.0, table 1**).

### 9.1.3

#### Wagons

a) carrier wagons of combined transport with:

- a compatibility code  **and** where necessary an additional plate with positive correction digit



Ex. +23 applicable on all coded lines

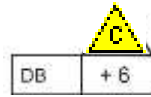

Ex. +6 applicable only on DB Netz coded lines.

or

- a plate  with correction digit (in accordance with bi-/multilateral agreement)

Compatibility code and correction number line applicable only on the coded lines of the networks indicated.

	
DB	-3
OS	-2
000 000 000 000	0

b) flat wagons with spigots<sup>2)</sup>

c) flat wagons with wooden floors<sup>2)</sup>

#### Method of loading

- On flat containers with raised end walls and/or side walls, the load must not foul the loading gauge of any of these walls lengthways, crossways or vertically.
- The end walls of flat wagons, whether with or without sheeting, must be secured by twistlocks.
- The moveable parts of these end walls and side walls must also be secured against unintentional movements.
- Stacked empty flats where the top is loaded with related flat items up to a weight of not more than 1500 kg, load securing as per the loading method 9.0.1
- When loading on carrier wagons with inward folding spigots that do not have a safety mechanism against folding, additional safety measures must be taken to prevent the ILU from tipping over during windy conditions.
- SBs, special swap bodies, and Cts must rest flat on four castings. A tolerance on one casting of up to 10mm between the base of the spigot and the lower part of the corner fitting/piece in a vertical direction is permitted. The underside of the spigot head must be engaged.
- The wagon loading diagram must be complied with; an ILU must not be loaded above the centre bogie or the buffing and draw gear.

Special provisions for loading on pocket wagons:

Flats of all length groups can be transported without intermediate or middle supports.

#### Securing

- The load is secured by means of spigots.
- Flats to be secured against tipping/ falling from the wagon as a result of wind in accordance with loading method 9.0, tables 3 and 4.
- On wagons as per c), loads are secured:
  - by fixed lateral guide pieces, **or**
  - wooden guide pieces measuring 30x5x5 cm.
- The wooden pieces are to be fixed in place by means of a nail (Ø 5 mm) per 1500 kg of load mass and with at least two nails per wooden piece.
- Flat containers stacked empty may only be carried on combined transport wagons if they do not foul the loading gauge, and if they are of the same design type, are of the same length, and are held together with connecting pieces<sup>3)</sup> which are themselves secured by twistlocks all of the same design or are bolted together.
- If an automatic or semi-automatic locking system is in place, the locking status must be identifiable visually.
- If a manual locking system is in place, the lever must lock in place when in the "locked" position such that it may unlock on its own or unintentionally.
- If connecting pieces<sup>3)</sup> without twistlocks are used, the stacked flat containers must be bound together using at least two bindings<sup>4)</sup> with edge protection for the sharp edges. Only securing straps may be used as bindings.

<sup>2)</sup> If the profile data resulting from loading method 9.0, Table 1 is exceeded, these consignments may only be conveyed as special consignments.

<sup>3)</sup> The dimensions of the connecting pieces must correspond to the stresses resulting from the dynamic effects produced during carriage by rail.

<sup>4)</sup> Tensile breaking strength of bindings (straight pull): 1400 daN minimum

- For stacked flat containers, the collapsed end walls of the flat containers in the upper part are to be held down (prevented from lifting) using bindings<sup>4)</sup>

### **Additional indications**

General indications: see loading methods 9.0 and 9.0.1,  
Load of wagons: see information sheet 0.1  
Maximum dimensions of loads: see information sheet 0.2,  
Covering of loads: see information sheet 0.3,  
Bulk goods: see information sheet 0.4,  
Single-use bindings<sup>5)</sup>: see information sheet 0.6.

---

<sup>4)</sup> Tensile breaking strength of bindings (straight pull): 1400 daN minimum

<sup>5)</sup> The minimum breaking strength (straight pull) corresponds to double the permitted tensile force (LC); this concerns only synthetic straps, woven straps and load securing straps.



### 9.1.4 Heavy-duty swap bodies

Single wagons and groups of wagons (for conveyance conditions see loading method 9.0)

Wagons in block trains or combined transport  
Wagons with long-stroke shock absorbers

#### Type of goods

Heavy-duty swap bodies (swap bodies with a total permissible mass of more than 36 000 kg).

These loading units need special restraining devices on the carrying wagon to transmit the higher forces

With code number plate :

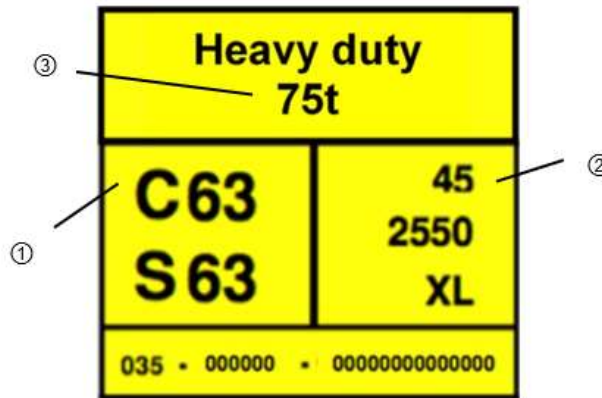

The profile number on the code number plate means that

- The heavy-duty swap body do not exceed a defined width:
  - ① - C00 = area according to profile compliant with IRS 50596-6, max. width 2550 mm,
  - C000 = area according to profile compliant with IRS 50596-6, width greater than 2550 mm and not greater than 2 600 mm max.,
- ② The heavy-duty swap body is allocated a length code on the basis of the distance between the centres of its corner fittings, its external length and its overhangs. The length code must be observed when positioning the heavy-duty swap bodies on the carrier wagon considering the relevant loading diagram.

Heavy-duty swap bodies with upper castings must, in addition, bear a valid CSC approval plate.

The date of the next overhaul must be indicated on the CSC approval plate or next to it.

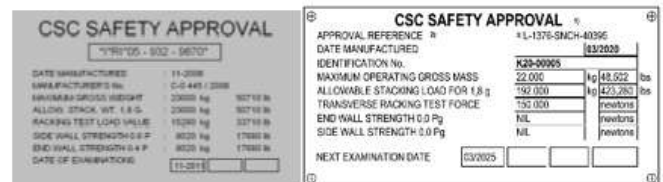

Example: current

Example: new

Loading units with an ACEP marking should be monitored permanently.

The date of the next overhaul is not indicated.

The marking of the approval authority must be present.

The legs must be folded up, locked and secured by means of a ratchet.



- ③ The number indicates the total weight of the heavy duty swap body

### 9.1.4

The grab-handling grooves if present, must be in perfect condition, and to prevent longitudinal movement of the grab handles they must have a stop at a distance of 500 mm on each side.

Their position must be indicated by means of a yellow or contrasting band measuring approx. 100 mm-high placed above them. Any sheeting protection plates placed above the grab-handling grooves must not project above the surface of the grab-handling groove stops. They must not be bent or detached.

- They must also be indicated by coloured marking.
- Sliding sheeting (curtain) must not encroach into the area where the grab-handling grooves are located.



Heavy duty swap bodies with reinforced tarpaulins for the transport of loads subject to settlement should be provided with an additional plate on the front wall or next to the code number plate



- Goods loaded in accordance with the applicable load certificate can touch the tarpaulin (e.g. car tyres with load certificate, etc.)
- Good and securing methods can not come into sharp edge contact with the tarpaulin or damage it.
- Heavy duty swap body does not exceed the maximum width in accordance with the code number plate.
- These swap bodies are allowed to be transported up to 140 km/h

### Wagons

Carrier wagons of combined transport with:

- a compatibility code  and  where necessary an additional plate with positive correction digit



Ex. +23 applicable on all coded lines

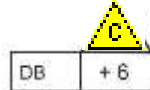

Ex. +6 applicable only on DB Netz coded lines.

or

- a plate  with correction digit (in accordance with bi-/multilateral agreement)

Compatibility code and correction number line applicable only on the coded lines of the networks indicated.

	
DB	-3
FS	-2
PL	0

A loading diagram is positioned on the wagon with marking of reinforced tensioning fittings.

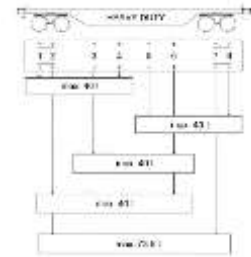

### Method of loading

- The heavy-duty swap body must rest on four castings.
- Any spigots or twist-locks placed under the heavy-duty swap body and not required for use are folded down or away and secured in that position.
- The heavy-duty swap body may only be loaded in the position that is permitted in the loading diagram for its total permissible weight.

Note: Swap bodies for heavy loads, which are empty or loaded, or loaded with a maximum total mass of 36t, may also be loaded onto all carrier wagons with a compatibility code  (with or without correction digit) without reinforced tensioning fittings, and taking the wagon loading diagram into account.

- When loading on carrier wagons with inward folding spigots that do not have a safety mechanism against folding, additional safety measures must be taken to prevent the ILU from tipping over during windy conditions.
- SBs, special swap bodies and Cts must rest flat on four castings. A tolerance on one casting of up to 10mm between the base of the spigot and the lower part of the corner fitting/piece in a vertical direction is permitted. The underside of the spigot head must be engaged.
- The wagon loading diagram must be complied with; an ILU must not be loaded above the centre bogie or the buffing and draw gear.

**Securing**

- The load is secured by means of reinforced spigots or reinforced tensioning fittings in accordance with loading diagram.
- Securing against tipping/ falling from the wagon as a result of wind in accordance with loading method 9.0, tables 3 and 4.

**Additional indications**

General indications: see loading methods 9.0 and 9.0.1,  
Load of wagons: see information sheet 0.1  
Maximum dimensions of loads: see information sheet 0.2,  
Covering of loads: see information sheet 0.3,  
Bulk goods: see information sheet 0.4

## 9.2 Containers

Single wagons and groups of wagons (for conveyance conditions see loading method 9.0)

Wagons in block trains or combined transport  
Wagons with long-stroke shock absorbers

### Type of goods

Containers (Cts)

- Cts must bear a valid CSC approval plate.

The date of the next overhaul must be indicated on the CSC approval plate or next to it.

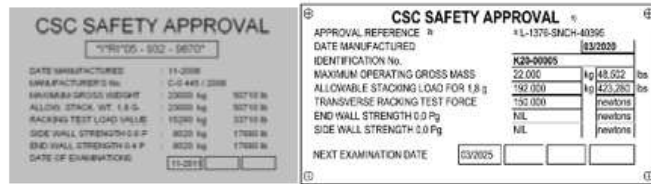

Example: current

Example: new

Cts with an ACEP marking should be monitored permanently. The date of the next overhaul should not be indicated. The marking of the approval authority must be present.



- Cts have
  - Markings indicating their height or their height and width (in accordance with ISO6346), e.g.:

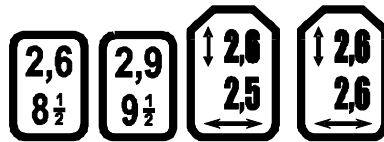

- These markings are mandatory for Ct's with a height greater than 8 ½ feet. If these markings are absent the width and height should be measured or determined according to Table 1 (dimension codes).
- For Ct's longer than 8 ½', in addition to the height indication, there is a black/yellow marking on the corner pieces

- |   |   |
|---|---|
| i | c |
|---|---|

 : is optional

- or 

i	t
---	---

 in connection with the distinctive sign: is optional.

- Cts are allocated a C code number / a container height module Ct depending on their dimensions and in accordance with table 1.

Class 1 containers according to ISO 668 do not require a code number plate. They can be transported in CT on the basis of the dimensions code C/ container height module Ct according to Table 1.

- If a Ct has a code number plate, only information of this code number plate shall be considered.

- ILUs that do not comply with ISO 668 shall be provided with a code plate in accordance with UIC Leaflet 592, 2013 edition.

- Ct's shall not have any elements protruding beyond their frame<sup>1)</sup>.

### Exceptions:

- Specific coding numbers (see Table 1) may be assigned to containers admitted before the publication of UIC Leaflet 592, 2013 edition, based on the setback defined for the upper corner pieces and the maximum permissible height of 2.6 m. These containers do not bear a code number plate.

- Containers with a height of more than 2.6 m, which were accepted before the publication of Leaflet 592, 2013 edition, may be transported in CT on the basis of their dimensions code (see Table 1). The deduced code numbers are agreed and apply only under bi-/multilateral agreements. These containers do not carry a code number plate.

<sup>1)</sup> Conveyance solely as a coded swap body with corresponding length code.

Table 1

Dimensions code (XXX)		Class 1						Class 2				Class 3											
		9	8	0	2	4	5	6	C <sup>1)</sup>	D <sup>1)</sup>	C R	D S	E T	F U	L <sup>2)</sup>	M <sup>2)</sup>	L	M	N	P			
Width	[m]	2,438						2,5				> 2,438 ≤ 2,5				2,6				> 2,5			
Height	[Feet]	≤ 4'	4'3"	8'	8'6"	9'	9'6"	> 9'6"	8'6"		8'6"	9'	9'6"	> 9'6"	8'6"		8'6"	9'	9'6"	> 9'6"			
	[m]	≤ 1,219	1,295	2,438	2,591	2,743	2,896	> 2,896	2,591	2,6	2,591	2,743	2,896	> 2,896	2,591	2,6	2,591	2,743	2,896	> 2,896			
Compatibility	Codification	C00	C00	C00	C12	C29	C44	— 9.1 <sup>1)</sup>	C12	C13	— 9.1 <sup>1)</sup>				C331	C332	— 9.1 <sup>1)</sup>						
	Module ct	1	1	1	2				2	3					2	3							
maximum permitted dimensions in accordance with		ISO 6346 ISO 668						UIC leaflets 592-2:2004 / 592:2010				UIC leaflets 592-2:2004 / 592:2010											
Pictograms		h > 2,6 						h > 2,6 				h > 2,6 				h > 2,6 							

a) ILUs shall be fitted with codification plates and shall be transported as codified ILUs in accordance with Loading Method 9.1.

Special arrangements for ILUs approved before 2010 are possible.



1) Class 2 containers shall be marked with pictograms indicating a maximum width of 2.5 m and a maximum height of 2.6 m in order to be conveyed by CT.

2) Class 3 containers shall be marked with pictograms indicating a maximum width of 2.6 m and a maximum height of 2.6 m in order to be conveyed by CT.



## 9.2

### Wagons

- a) Carrier wagons with:
- wagon compatibility code  or  and eventually additional plate
- or
- plate with correction digit (in accordance with bi-/multilateral agreement).

	
	+22
	
UNDF	-3
IS	-2
ISO 4011-1000	0

- b) Flat wagons with spigots<sup>2)</sup>  
c) Flat wagons with wooden floors<sup>2)</sup>

### Method of loading

- The Ct must rest on four castings.
- On 45' containers with more than four castings in the lower part, the castings with a distance between centres of 40' should be used for rail transport. For all other containers with over four fastenings in the lower part, the castings to be used are those fitted below the supporting column.
- Any spigots or twist-locks placed under the Ct and not required for use are folded down or away and secured in that position.
- When loading on pocket wagons with additional marking  intermediate timbers/inserts or rolling beams (if present) should be placed into active position, though transport is possible without intermediate timber/rolling beam.
- Containers loaded in several tiers. The heaviest Ct must always be loaded in the lower tier.
- When loading on carrier wagons with inward folding spigots that do not have a safety mechanism against folding, additional safety measures must be taken to prevent the ILU from tipping over during windy conditions.
- SBs, special swap bodies, and Cts must rest flat on four castings. A tolerance on one casting of up to 10mm between the base of the spigot and the lower part of the corner fitting/piece in a vertical direction is permitted. The underside of the spigot head must be engaged.
- The wagon loading diagram must be complied with; an ILU must not be loaded above the centre bogie or the buffing and draw gear.

### Securing

Using spigots or turn-screws on wagons as per a) and b).

Using fixed lateral guide-pieces or wooden guide-pieces on the wagon as per c):

- for Cts with a bottom frame: min. 300x50x50 mm,
- for Cts without a bottom frame: min. 1000x50x50 mm.

The pieces are to be fixed in place by means of a nail ( $\varnothing$  approx. 5 mm) per 1500 kg of load mass and with at least two nails per piece.

Containers stacked empty may only be carried on carrier wagons of combined transport if they do not foul the loading gauge, and if they are of the same design type, are of the same length, and are held together with connecting pieces<sup>4)</sup> which are themselves secured by twistlocks all of the same design, or are bolted together.

- If an automatic or semi-automatic locking system is in place, the locking status must be identifiable visually.
- If a manual locking system is in place, the lever must lock in place when in the "locked" position such that it may unlock on its own or unintentionally.
- If connecting pieces<sup>3)</sup> without twistlocks are used, the stacked flat containers must be bound together using at least two bindings<sup>4)</sup> with edge protection for the sharp edges. Only securing straps may be used as bindings.

To prevent Cts tipping or falling from the wagon as a result of wind, they should be firmly secured as specified in loading method 9.0, tables 3 and 4.

### Additional indications

General indications, see loading methods 9.0 and 9.0.1,

Load of wagons: see information sheet 0.1

Maximum dimensions of loads: see information sheet 0.2,

Covering of loads: see information sheet 0.3,

Bulk goods: see information sheet 0.4,

Single-use bindings<sup>5)</sup>: see information sheet 0.6.

<sup>2)</sup> If the profile data resulting from loading method 9.0, table 1 is exceeded, these consignments may only be transported as exceptional consignments.

<sup>3)</sup> The dimensions of the connecting pieces must correspond to the stresses resulting from the dynamic effects produced during carriage by rail.

<sup>4)</sup> Tensile breaking strength of bindings (straight pull): 1400 daN minimum.

<sup>5)</sup> The minimum breaking strength (straight pull) corresponds to double the permitted tensile force (LC); this concerns only synthetic straps, woven straps and load securing straps.



## 9.3 Demountable bodies (DBs)

Single wagons and groups of wagons (for conveyance conditions see Loading Guidelines 9.0)

Wagons in block trains or combined transport  
Wagons with long-stroke shock absorbers

### Type of goods

DBs (rolling) with a maximum length of 5950 mm for horizontal transshipment and with a UIC code number plate

#### ① Compatibility code

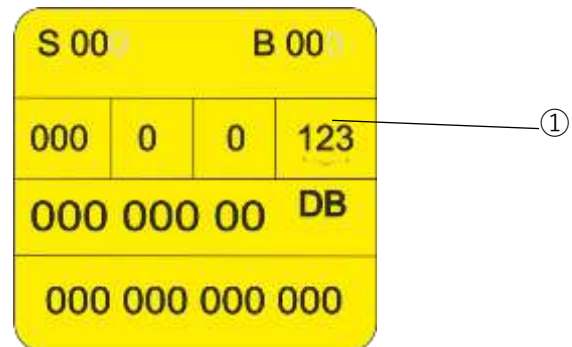

The profile number on the code number plate indicates that

- the demountable body does not exceed a set width:
  - **B 00** = maximum width of 2500 mm,
  - **B 000** = width higher than 2500 mm up to a maximum of 2600 mm,
- the height and roof shape do not exceed a gauge profile set by UIC.

DBs with a width of 2550 mm have an additional plate in their code number plate or next to it:



### Wagons

Carrier wagons with two or three underframes for carrying DBs, pivoting up to 45° on both sides and with the marking:

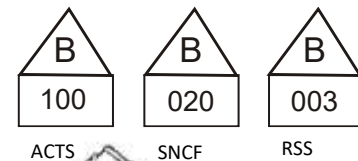

### Method of loading

- The DB is loaded by a truck equipped with a device using chains or hooks on the pivoting frame turned towards the outside of the wagon. This operation fouls the loading gauge laterally.

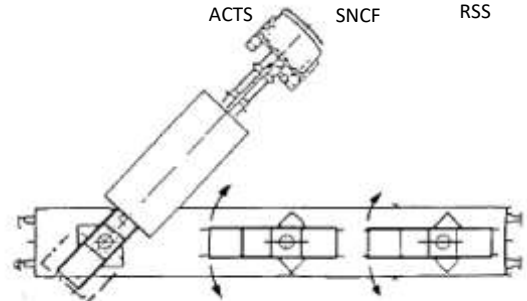

- The distance at which the pivoting underframe of the DB may project over the contiguous line must be indicated by means of a pictograph placed on the wagon.

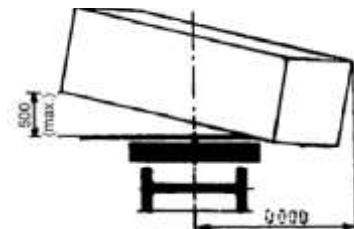

- The number, marked on the wagon, of pivoting underframes which may be in a pivoted position and have been secured against tipping must be observed.
- The carrying capacity of the pivoting underframe must be observed.
- Carrier wagons with pivoting underframes in a pivoted position may not be moved

### 9.3

- There are several DB systems, categorised according to the type of load they carry and how they are fixed to the carrier wagon. The systems are identified by the compatibility codes listed below:
  - ACTS systems: number 1 in the first position, other positions on zero,
  - SNCF system: number 2 in the second position, other positions on zero,
  - RSS system: number 3 in the third position, other positions on zero.
- The compatibility code of the DB must match the compatibility code of the carrier wagon for loading.
- Several DBs may also fulfil the requirements of several different systems and therefore be loaded on the suitable carrier wagon in accordance with the following table:

System and combination	Compatibility code
ACTS	100
SNCF	020
RSS	003
ACTS + SNCF	120
ACTS + RSS	103
ACTS + SNCF + RSS	123
SNCF + RSS	023

#### Securing

- DBs must be locked to the pivoting underframes to prevent displacement or lifting.
- The pivoting underframes must be secured against rotation by means of two protection devices acting separately and in accordance with the method of use of the pivoting underframe system.

#### Additional indications

General indications, see loading methods 9.0 and 9.0.1,  
Load of wagons: see information sheet 0.1  
Maximum dimensions of loads: see information sheet 0.2,  
Covering of loads: see information sheet 0.3,  
Bulk goods: see information sheet 0.4.

### 9.4 Semi-trailers (STs)

Single wagons and groups of wagons

Wagons in block trains or combined transport  
Wagons with long-stroke shock absorbers

#### Type of goods

Semi-trailers (STs)

- a) with a UIC code number plate for loading on a pocket wagon P  
required height of the seating device: 113 cm

S00	P00		
00.000.0000	000 000	●	000 000 000 000 000 000

- b) for loading on a pocket wagon (P) with a broader clearance envelope  
(current regulations)  
required height of the seating device: 113 cm

	(P)00		
00.000.0000	000 00	●	000000 00000000

↓.....required height of the seating device: 98 cm

- c) with a UIC code number plate for loading on a pocket wagon P with a broader clearance envelope and defined compatibility code and seating device heights

	(P)00		
00.000.0000	000 00	●	000000 00000000

①                      ②

- ① Height of the seating device: 113 cm, 98 cm, 88 cm or 85 cm  
② Identification letter defined by UIC for a specific pocket wagon with a defined clearance envelope (wagon compatibility code)

S000	P000	000 cm	a	b	c	d	e	f
00.000.0000	000 00	●					000000 00000000	

- d) with a UIC code number plate for loading on various pocket wagons P with broader clearance envelopes (new regulations) and defined seating device heights

S402	P402	88 cm	e	f			
S400	P400	85 cm	d				
00.000.0000	000 00	●		000000 00000000			

- e) STs with sheeting suitable for transport on trains running at over 120 km/h to 140 km/h shall be compliant with EN 12642 (Code XL) and bear "XL" marking on the code number plate or additional plate

Code XL

- f) ST with a codification plate in accordance with EN 13044

#### Marking

- ③ of the height of the seating device,  
④ of the strength of the ST structure The indication XL meets the requirements of EN 12642 and must be present for transport on trains running at over 120 km/h.  
⑤ c3 = number of the position on the carrier wagon of the notch for the moveable scotch for the axle which is to be scotched.

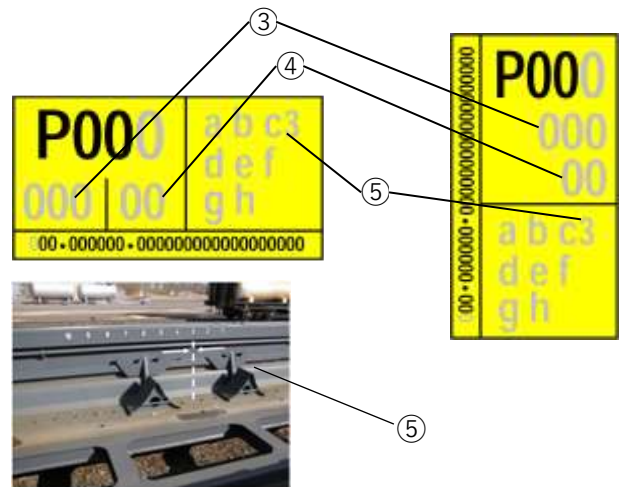

- g) With a codification plate compliant with EN 13044 SR loading on wagons with two codification plates corresponding to several setting devices heights  
Example:

This example shows a ST with two codification plates corresponding to several heights of setting devices. This ST can be transported both on the pocket wagon with a setting device height of 113 cm and on the unified pocket wagon (only P in the triangle). It can also be transported with a wagon with a setting device height of 98 cm when the compatibility code of the pocket wagon (c,e,f,g) matches the compatibility code on the codification plate.

#### Two codification plates

Height of setting device

Compatibility code on pocket wagons

98cm

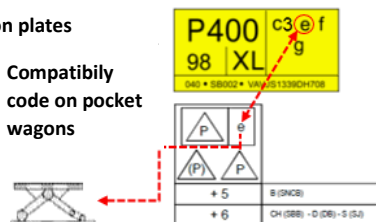

Height of setting device

113cm

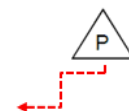

## 9.4

The profile number on the code number plate means that

- the ST does not exceed a set width:
  - P 00 = maximum width of 2500 mm,
  - P 000 = width higher than 2500 mm up to a maximum of 2600 mm,
- the height and roof shape do not exceed a gauge profile set by UIC.

⑥ Characterises the strength of tarpaulins permitted for the transport of loads subject to settling.

- Goods loaded in accordance with the applicable load certificate can touch the tarpaulin (e.g. car tyres with load certificate, etc.)
- Good and securing methods can not come into sharp edge contact with the tarpaulin or damage it.
- The ST does not exceed the maximum width in accordance with the code number plate.
- These STs are allowed to be transported up to 140 km/h

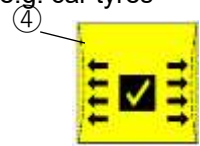

### Wagons

Pocket wagons equipped with seating device with a clearance envelope approved by UIC for ST's loading

- as per a) with wagon compatibility code P with or without correction digit

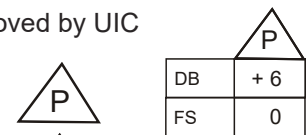

- as per b)<sup>1)</sup> with wagon compatibility code (P)



- as per c), d), e), f) and g) with wagon compatibility: code e, for example with or without correction digit



### Method of loading

- Before loading the seating device must be adjusted and locked at the prescribed height in accordance with codification plate
- When loading STs on pocket wagons with built-in wheel cradles/moveable wheel scotch segments, the axle to be placed in the cradle must be marked with the following pictograms:



⑦ Long STs (rear axle secured)

⑧ Long STs with short three-axle undercarriage (rear axle secured)

⑨ Before loading move the wheel scotch segment crosswise vis-à-vis the wagon axis

⑩ Medium-length STs (rear axle secured)

⑪ Short STs (front axle secured)

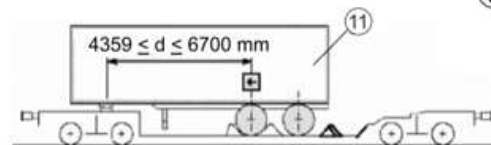
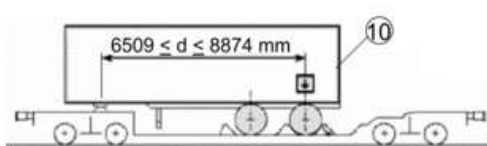
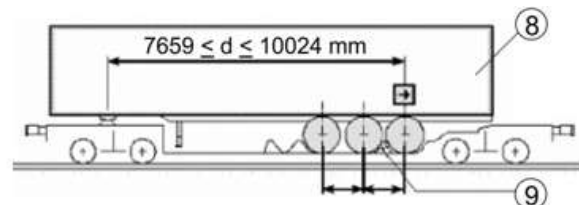
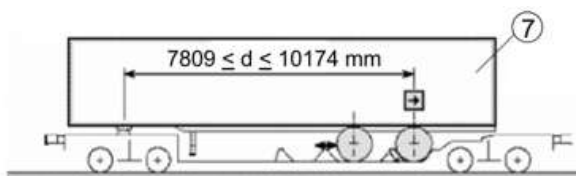

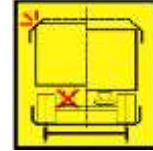

<sup>1)</sup> In case of STs with , it is necessary for the wagon to be equipped with a seating device with adjustable height (98 cm)

- STs with pneumatic suspension must be indicated by means of a pictograph. Before being loaded onto the wagon their brakes must be deactivated while parked on the road, then their pneumatic system must be emptied of all air. The pneumatic suspension must be lowered and completely pressure-free for the duration of transshipment and transport.
- The pocket wagon and ST must have matching compatibility codes for loading.



- STs:

- bearing the marking P without a compatibility code may be loaded on pocket wagons with wagon compatibility codes P, (P) or P with ST compatibility code a, b, c, d, e, f, g, h and i for a seating device height of 113 cm.
- bearing the marking ↓ (P) without a compatibility code may be loaded on pocket wagons with wagon compatibility codes (P) or P with ST compatibility code a, b, c, d, e, f, g, h and i for a seating device height of 98 cm.
- bearing the marking (P) without a compatibility code may be loaded on pocket wagons with compatibility codes (P) or P with ST compatibility code a, b, c, d, e, f, g, h and i for a seating device height of 113 cm.
- bearing the marking guide-block  must not be loaded on pocket wagons with the marking 
- with a sheeted structure and with pneumatic suspension (1) and without a compatibility code describing the envelope (letter a, b, c, d, etc.) (2) and with a seating device height of 113 cm may be loaded on pocket wagons with the pictogramme  with a seating device height of 98 cm if the wagon does not have a seating device height of 113 cm.

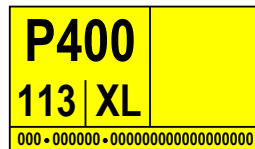
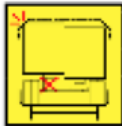

The ST may only touch the pocket wagon at its wheels and seating device.

- The loading and unloading of the ST onto the pocket wagon may only be carried out with the released brake of the ST.
- The ST may be transported with the brake on or off.
- STs may only be transported with retracted or folded down legs. Damaged legs must be secured.
- The lateral and rear underrun protection devices must, as much as the design allows it, be raised or retracted and secured by the driver of the semi-trailer before the semi-trailer is loaded onto the wagon. If the loading has been carried out in conformity, no contact shall be possible between the underrun protection and the components of the wagon.
  - For pocket wagons with extended envelope space (indicated by one of the compatibility codes: e, f, g, h, i), the lateral and rear underrun protection device do not have to be raised.
- The grab-handling grooves must be in perfect condition. They must have stops at a distance of 500 mm on both sides to prevent longitudinal movement of the grab handles.
- Their position must be indicated by means of a yellow or contrasting band measuring approx. 100 mm-high placed above the grooves. Any sheeting protection plates placed above the grab-handling grooves must not project above the surface of the grab-handling groove stops. They must not be bent or detached. They must also be indicated by coloured marking.
- Sliding sheeting (curtainsider) must not encroach into the area where the grab-handling grooves are located.
- The strap loops of sliding sheeting must always be properly hooked and tensioned.
- All of the spigots positioned under the ST must be folded down.

## 9.4

### Securing

Along the length of the wagon:

- by the built-in wheel cradles and/or moveable wheel scotch segments. Longitudinal play may be possible depending on the type of design
- or**
- on wagons without wheel cradles, secure the ST by slotting its coupling pin into the seating device.
- Overload of the pin is signalled by the triggering of the crash elements built into the seating device. In such cases the wagon keeper's instructions must be followed.

Across the wagon:

- at wheel level by the wagon pocket **and**
- by the ST coupling pin slotted into the seating device. Correct locking is indicated in accordance with the design of the seating device.

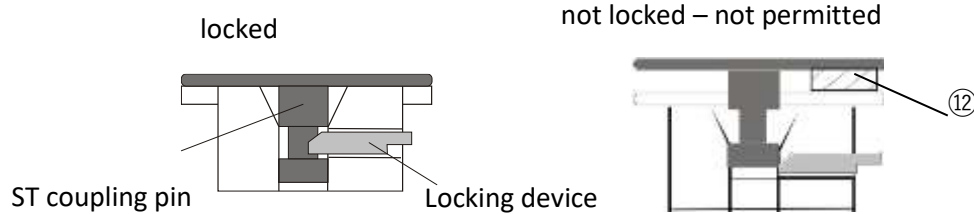

⑫ STs with a P marking and equipped with guide-blocks (semi-trailers with steered rear axle) may not be loaded on pocket wagons with the following pictogram



### Additional indications

- General indications: see loading methods 9.0 and 9.0.1,
- Load of wagons: see information sheet 0.1
- Maximum dimensions of loads: see information sheet 0.2,
- Covering of loads: see information sheet 0.3,
- Bulk goods: see information sheet 0.4.

The transport of STs without S coding to Great Britain is not permitted.

### 9.4.1 Semi-trailers Novatrans system (“N”)

Single wagons and groups of wagons (for conveyance conditions see loading guideline 9.0)

Wagons in block trains or combined transport  
Wagons with long-stroke shock absorbers

#### Type of goods

Semi-trailers, Novatrans system (“N”) with a UIC code number plate for loading on “N” pocket wagons

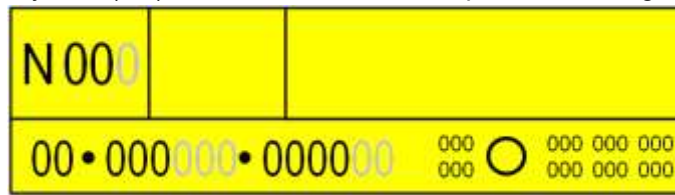

The semi-trailers are equipped with lateral skids with a longitudinal groove under the underframe solebars.

Semi-trailers with “N” coding are marked with the following pictograph:

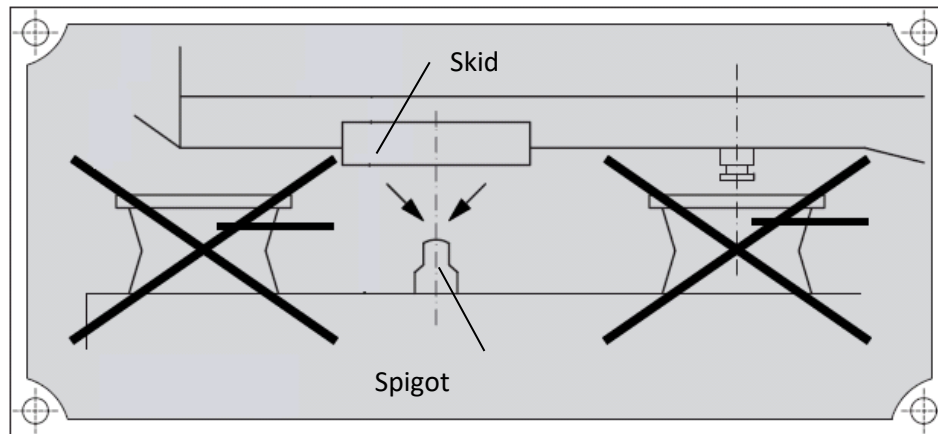

The profile number on the code number plate means that

- the ST does not exceed a set width:
  - N 00 = max. width of 2500 mm,
  - N 000 = width higher than 2500 mm up to a maximum of 2600 mm,
- the height and roof shape do not exceed a gauge profile set by UIC.

Code number plate compliant with EN 13044 for loading on various P-type pocket wagons with compatibility code, seating device height of 98 cm and “N”-type skid system.



#### Wagons

Pocket wagons of type 1a and 1b for loading semi-trailers with wagon compatibility code .

## 9.4.1

### Method of loading

On pocket wagons

- type 1a, the seating device must be removed,
- type 1b, the seating device must be pushed up to the front bolster of the wagon and immobilised.

The wheels of the ST rest in the cradle of the wagon pocket. The coupling pin is clear and not slotted into the seating device. The lateral skids of the ST rest on the supporting plates of the carrier wagon, covering the spigot by their groove.

With the exception of wheels, skids and solebars in the prescribed supporting area, no element of the semi-trailer is in contact with the carrier wagon.

- STs with pneumatic suspension must be indicated by means of a pictograph. Before being loaded onto the wagon their brakes must be deactivated while parked on the road, then their pneumatic system must be emptied of all air. The pneumatic suspension must be lowered and completely pressure-free for the duration of transshipment and transport.

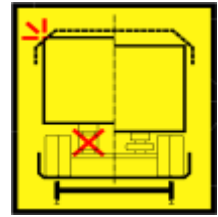

- STs may only be transported with retracted or folded down landing gear. Damaged landing gear must be secured.
- The lateral and rear underrun protection devices must, as much as the design allows it, be raised or retracted and secured by the driver of the semi-trailer before the semi-trailer is loaded onto the wagon. This operation is not necessary on pocket wagons with no built-in wheel cradles.
- The grab-handling grooves must be in perfect condition. They must have stops on both sides to prevent longitudinal movement of the grab handles. Their position must be indicated by means of a yellow or contrasting band measuring approx. 100 mm-high located above the grooves. Any sheeting protection plates placed above the grab-handling grooves must not project above the surface of the grab-handling groove stops. They must not be bent or detached. They must also be indicated by coloured marking.
- The STs with sliding sheeting (curtainsider) suitable for transport on trains running at over 120 km/h and up to 140 km/h must be compliant with EN 12642 (Code XL) and bear "XL" marking on the codification plate, or an additional plate

Code XL

### Securing

- longitudinal and lateral securing of the ST by the wheels resting in the pocket and the spigots being slotted into the longitudinal grooves of the skids. This allows minor longitudinal movement of the semi-trailer depending on the longitudinal play of its suspension.

### Additional indications

General indications: see loading methods 9.0 and 9.0.1,

Load of wagons: see information sheet 0.1

Maximum dimensions of loads: see information sheet 0.2,

Covering of loads: see information sheet 0.3,

Bulk goods: see information sheet 0.4.

## Chapter 10: Barrels



## 10.1 Barrels

Single wagons and groups of wagons

Wagons in block trains or combined transport  
Wagons with long-stroke shock absorbers

### Type of goods

Barrels

### Wagons

Wagons with walls or sides

### Method of loading

- ① Barrels should be loaded upright and in compact formation over the whole loading surface, with intermediate space filled in.
- ② When barrels are loaded in two tiers (only on E, G, H and Si wagons), the tiers should be separated using panels (e.g. wooden panels).  
When loading barrels of different dimensions, barrels of similar dimensions should be grouped together and separated (e.g. using wooden panels).

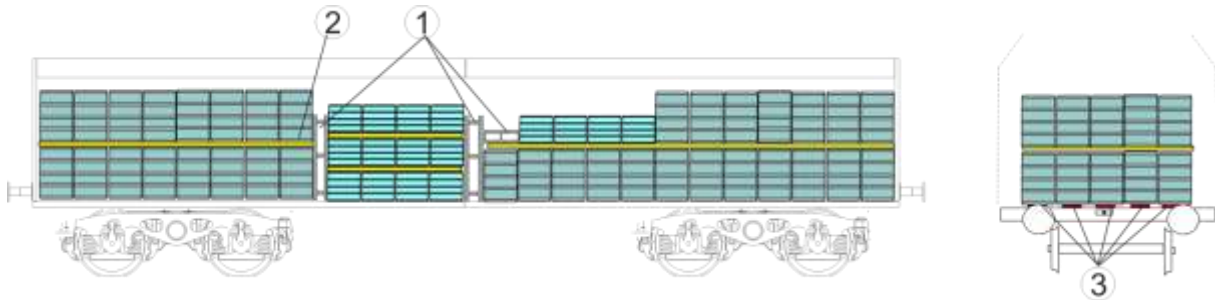

### Securing

- ③ By the walls and sides. In the vicinity of the side doors additional measures are used to ensure stability: barrels bound together into groups (breakings strength of bindings: at least 1000 daN) friction-enhancing inserts or timber scotches used.  
Scotches should be secured on each side with one 5 mm diameter nail per 1500 kg load weight, and at least two nails per scotch.

### Additional indications

Load of wagons: see information sheet 0.1

Single-use bindings<sup>1)</sup>: see information sheet 0.6.

<sup>1)</sup> The minimum breaking strength (straight pull) corresponds to double the permitted tensile force (LC); this concerns only synthetic straps, woven straps and load securing straps.



## 10.2 Barrels in wagons with sliding walls

Single wagons and groups of wagons

Wagons in block trains or combined transport  
Wagons with long-stroke shock absorbers

### Type of goods

Barrels

### Wagons

Wagons with sliding walls and partitions (H..., I..., Li..., Si...)

### Method of loading

- ① Barrels should be loaded upright and in compact formation aligned one behind another, with intermediate spaces separated by partitions.
- ② If the barrels are loaded in tiers the tiers should be separated by panels.  
When loading barrels of different sizes, barrels of similar dimensions should be grouped together and separated e.g. using panels as required.

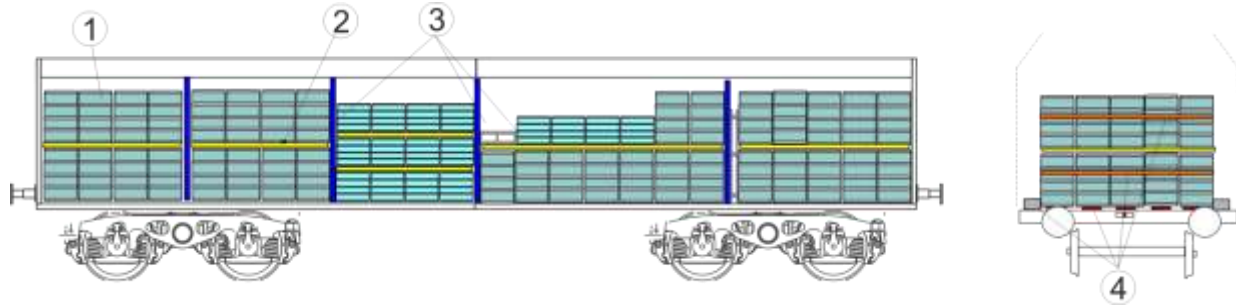

### Securing

- ③ - lengthways in the wagon by the partition walls,
- ④ - across the wagon by timber scotches, units (breaking strength at least 1000 daN) by binding groups of barrels together or using friction-enhancing inserts. Scotches should be secured on each side with one 5 mm diameter nail per 1,500 kg load weight, and at least two nails per scotch.  
Packages shall be bound together (breaking strength 1400 daN) with one binding

### Additional indications

Load of wagons: see information sheet 0.1

Single-use bindings<sup>1)</sup>: see information sheet 0.6.

Friction and coefficients of friction: see information sheet 0.8

Goods in wagons with sliding doors and lockable partition walls: see loading method 100.1

<sup>1)</sup> The minimum breaking strength (straight pull) corresponds to double the permitted tensile force (LC); this concerns only synthetic straps, woven straps and load securing straps, as well as lashing steel wire ropes and lashing chains.



## **Chapter 11: Palletized load units**



## 11.1 Formation of palletised load units

Single wagons and groups of wagons

Wagons in block trains or combined transport  
Wagons with long-stroke shock absorbers

### Type of goods

Cases, sacks, building materials, stone, slabs, paper, cardboard, casks, drums, products loaded on semi-pallets, fruit and vegetables in boxes or crates, etc.

### Loaded on

Flat pallets made of wood, plastic, pressboard, etc.

- ① - with feet / bearers designed and fastened to ensure they will not tip or break off.

### Method of loading

- ② Goods should be arranged on the pallet in stable and compact manner, with sides flush with the pallet edges (avoid offset or projecting goods)

- in interlocking layers (e.g. crates)
- stacked in criss-cross formation (e.g. sacks)

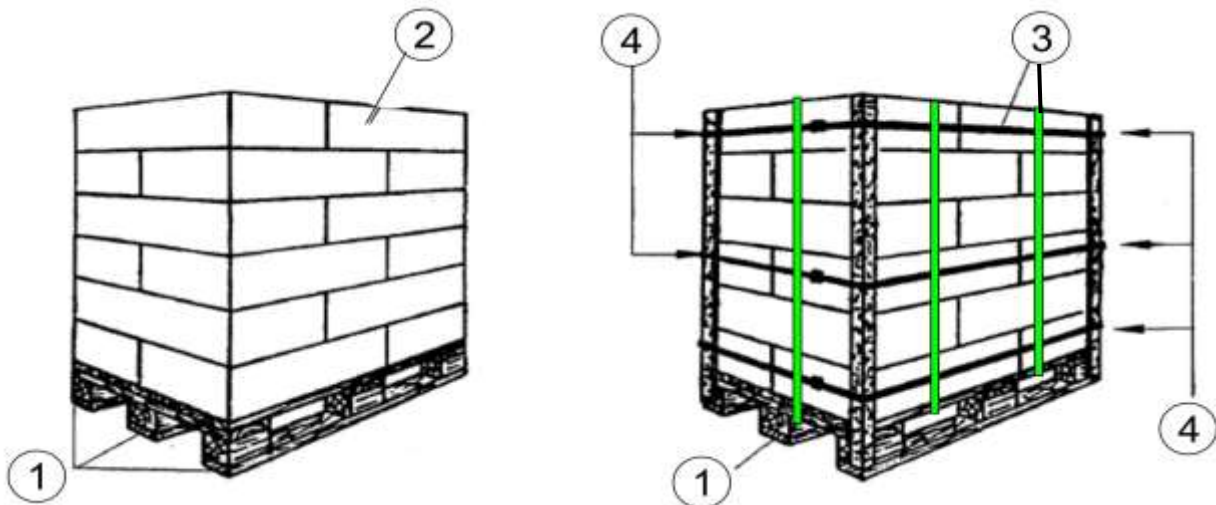

### Securing

Cohesion of load unit increased by:

- ③ - using steel strip, textile or synthetic bands (breaking strength 700 daN minimum) to encircle the load vertically and horizontally,
- ④ - for easily displaced goods with edge protection bound to the load, horizontal encircling bands, one to be placed:
- round the lower tier,
  - one around the middle, and
  - one towards the top of the load unit.
- shrink-fit or stretched plastic sheeting (the feet of the pallets must also be enclosed in the plastic sheeting). Such sheeting must withstand the mechanical stresses and climatic conditions occurring during carriage by rail. If necessary, it must be ensured that the sheeting can withstand the effects of biological conditions (micro-organisms, insects, etc.).
  - Use of:
    - inserts made from friction-enhancing material between individual layers or
    - special adhesives **or**
    - corner pieces.

### Additional indications

Single-use bindings<sup>1)</sup>: see information sheet 0.6,

Friction and coefficients of friction: see information sheet 0.8.

<sup>1)</sup> The minimum breaking strength (straight pull) corresponds to double the permitted tensile force (LC); this concerns only synthetic straps, woven straps and load securing straps, as well as lashing steel wire ropes and lashing chains.



## Chapter 20: Cable drums



## 20.1 Cable drums, loaded "gunshot"

Single wagons and groups of wagons

Wagons in block trains or combined transport  
Wagons with long-stroke shock absorbers

### Type of goods

Cable drums, loaded "gunshot" (eye to end)

### Wagons

Wagons with walls, sides or stanchions and wooden floor

### Method of loading

Cable drums should be loaded individually or in groups on cradles<sup>1)</sup>, clearance from floor 2-3 cm.

Cradles should be

- |   |  |   |
|---|--|---|
| <p>① set up as sleds</p> <p>③ - drum width at least <math>\frac{5}{10}</math></p> |  | <p>② fixed</p> <p><math>\frac{4}{10}</math></p> |
| of the drum diameter  |  |   |

- narrower drums should be secured against tipping by:

- ④ • props (for single drums; only to be used for groups if the individual drums are narrower than  $\frac{1}{4}$  of their diameter) of cross-section at least 7x15 cm, at an angle of approx. 45° and laid against the load at a point  $\frac{3}{4}$  of the way up.
- ⑤ • being tied together (for groups, only the two outer units in each case, as appropriate) with bindings with a breaking strength of at least 1400 daN.
- ⑥ - minimum clearances to the ends:

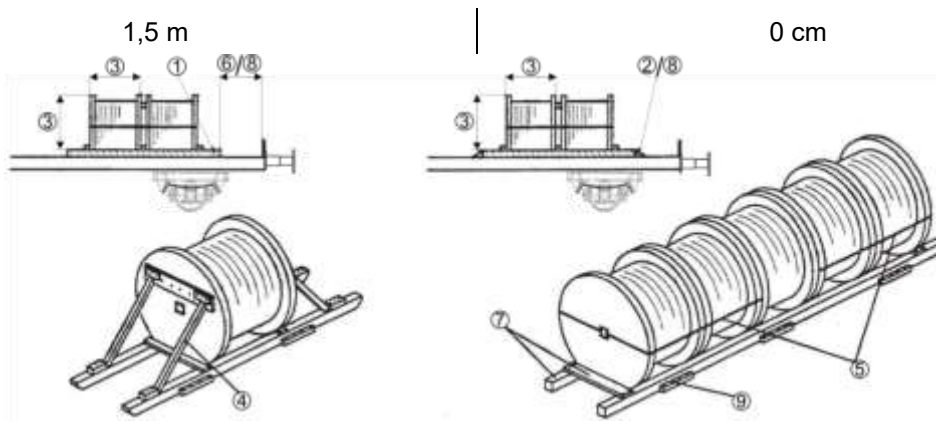

### Securing

⑦ by the cradles

- effective height of underlying timbers at least  $\frac{1}{12}$  of the drum diameter, though a minimum of 12 cm
- timber cross-section will depend on drum weight and diameter
  - for underlying timbers, e.g. 12x15 cm,
  - for cross-braces, e.g. 7x15 cm,
- timbers joined with four 160 mm nails (diameter 5 mm) on each or two through screws of at least 10 mm diameter.

⑧ - lengthways in the wagon:

- able to slide

- free space filled, or timber guide-pieces used (cross-section 5x10 cm min.). Number of nails on each side: one nail/400 kg.

⑨ - across the wagon:

- guide-pieces, at least two on each side (cross-section at least 5x10 cm), number of nails on each side one nail per 1500 kg, but at least two per guide-piece.

### Additional indications

Load of wagons: see information sheet 0.1,

Maximum dimensions of loads: see information sheet 0.2,

Single-use bindings<sup>2)</sup>: see information sheet 0.6.

<sup>1)</sup> For cable drums weighing over 10 t, the cradles must be either made of steel or reinforced with steel fittings.

<sup>2)</sup> The minimum breaking strength (straight pull) corresponds to double the permitted tensile force (LC); this concerns only synthetic straps, woven straps and load securing straps.



## 20.2 Cable drums, loaded "on the roll"

Single wagons and groups of wagons

Wagons in block trains or combined transport  
Wagons with long-stroke shock absorbers

### Type of goods

Cable drums, loaded "on the roll" (eye-to-side)

### Wagons

Wagons with walls, sides or stanchions and wooden floor

### Method of loading

Cable drums should be loaded

- ① - on timbers or
- ② - on wedged scotches
- ③ - clearance from floor 2 to 3 cm.
- ④ - clearances to end walls or ends at least  
50 cm | 10 cm
- ⑤ - drum width should be at least  $\frac{5}{10}$  of drum diameter, for wagons without walls at least  $\frac{7}{10}$ .
- ⑥ - narrower drums should be secured against tipping, for example by being tied together. Bindings should have a breaking strength of at least 4000 daN.

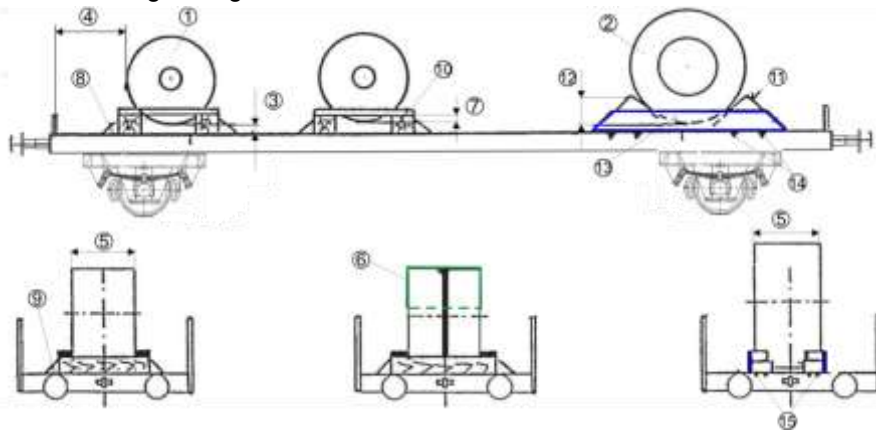

### Securing

Drums weighing up to a maximum of 7 t should be secured with timbers

- Cross-timbers
- ⑦
  - effective height at least  $\frac{1}{8}$  of the drum diameter,
  - timber width at least equal to height,
  - in each running direction
- ⑧
  - secured on the outside with at least two wooden scotches (scotch height approx.  $\frac{2}{3}$  of timber height)
  - scotches should be fastened with a total of  
one nail/500 kg | one nail / 2000 kg
- but at least two nails per scotch
- ⑨
  - secured laterally with scotches
  - scotches should be fastened on each side with a total of one nail per 1500 kg load weight, but at least two nails
- ⑩ - Supporting pieces
  - minimum cross-section 5x15 cm
  - fastened at each end with at least four nails
- Nails at least 5 mm in diameter with penetration of at least 40 mm
- ⑪ Drums weighing up to a maximum of 20 t should be secured with 2 wedged scotches.
- ⑫ - effective height of scotches at least  $\frac{1}{8}$  of drum diameter, scotch width at least  $\frac{2}{3}$  of scotch height.
- ⑬ - scotches should be covered on three sides with steel sheeting at least 6 mm thick.
- ⑭ - sheet on underside of scotches should have 8 steel spikes (2x4), 10-15 mm long.
- ⑮ - drums are prevented from lateral movement by resting against the lateral sheeting.

### Additional indications

Load of wagons: see information sheet 0.1,

Maximum dimensions of loads: see information sheet 0.2,

Single-use bindings<sup>1)</sup>: see information sheet 0.6

<sup>1)</sup> The minimum breaking strength (straight pull) corresponds to double the permitted tensile force (LC); this concerns only synthetic straps, woven straps and load securing straps, as well as lashing steel wire ropes and lashing chains.



## **Chapter 100/200: Miscellaneous**



## 100.1 Goods in wagons with sliding doors and lockable partition walls

### Type of goods

- palletised goods
- goods liable to tip
- part-loads

### Wagons

- ① - with sliding doors (H..ll..) and
- ② - moveable partition walls
- ③ • approx. 2,4 m wide and approx. 2 m high
- lockable every 45 mm

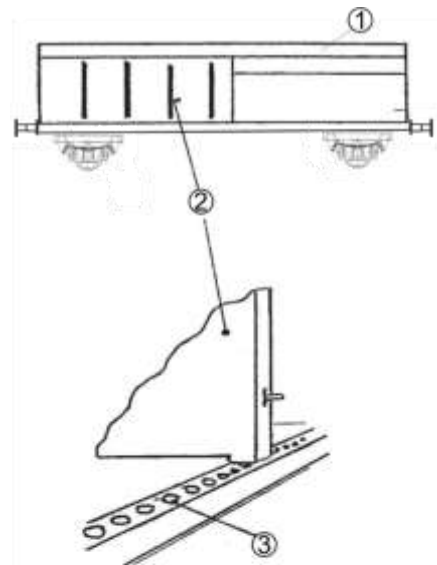

### Partition walls

Walls are unlocked as follows

- ④ - by pulling out the handles (one person)
- ⑤ - by raising the levers placed on the partition wall sides (two persons)

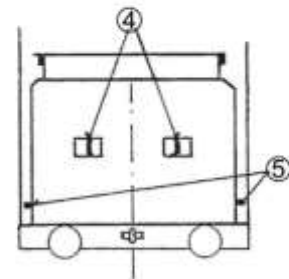

### Loading

- ⑥ - 5 t maximum against one partition wall
- ⑦ - 7 t maximum against two adjacent locked partition walls
- goods with these weights must be in contact with the partition walls over a surface at least 2,4 m wide and 0,7 m high

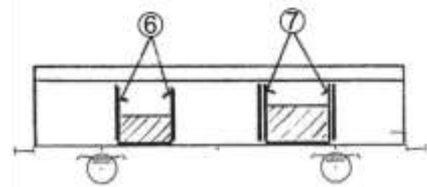

### Securing

Partition walls should be pushed up as close as possible to the goods and locked.

Partition walls not in use should be locked.

### Additional indications

Loading of bulk goods is not permitted

Load of wagons: see information sheet 0.1



**100.2 Wagons with strengthened sliding walls without code letters ii**

(in accordance with the strength requirements of UIC Leaflet 577 of 1.1.2012 ERRI-RP 17, 7th edition onwards)

Country Code UIC 920-14	Identification of the keeper	Wagons	
		Letter codes	Numbers
54	<u>CZ</u> - ČDC	Hbillnss	21 54 246 1 001-200
		Habbillns	31 54 278 0 000-299
		Hillmrrss (2 x Hbillnss)	21 54 293 6 001-050
		Kils	21 54 338 0 000-300
		Laails (2 x Kils)	21 54 430 7 001-050
55	<u>H</u> -RCH	Habbins	31 55 287 0 000-250
		Habbillnss	21 55 289 0 000-050
56	<u>SK</u> -ZSSKC	Hbillnss	21 56 245 7000-2 à 7041-6
		Hbis	21 56 224 5009-0 à 5499-3
		Hirrs	21 56 292 0001-9 à 0070-4
		Heirrs	21 56 291 8001-3 à 8016-1
		Habbillns	31 56 278 0001-6 à 0150-1
			31 56 277 0631-2 à 0814-4
68	D-AAE	Habbins	31 68 277 0 000-999
		Habbins	31 68 277 1 000-999
		Habbins	31 68 277 2 000-999
		Habbins	33 68 277 0 000-999
		Habbins	33 68 277 1 000-999
		Habbins	33 68 277 2 000-999
		Habbillns	31 68 278 0 000-999
		Habbillns	33 68 278 0 000-999
		Habbillns	33 68 287 0 000-500
74	<u>S</u> -GC	Habins	34 74 278 2 000-405
		Laaais	24 74 435 9 151-910
		Laaais	24 74 436 0 000-399
		Laaais	24 74 460 0 200-399
80	<u>D</u> -DB	Habis	34 80 275 5 476-595
		Habis	34 80 275 3 458-507
		Habis	33 80 276 3 750-889
		Hirrs	23 80 292 1 300-599
		Hirrs	23 80 292 1 775-799
		Hirrs	43 80 292 1 800-849
		Hirrs	23 80 292 1 800-999
83	I-MIR	Habills	31 83 285 2 000-714

**Loading method 100.2**

		Habilss	31 83 285 2 800-899
86	DK-DBCSC	Habins	31 86 278 3 000-063
88	B-BLX	Habins	35 88 278 2 800-999

**100.3 Wagons with high-strength side stanchions**

(compliant with the strength requirements defined in UIC Leaflet 577, point 4.4.3)

Country Code UIC 920-14	Identification of the keeper	Wagons	
		Letter codes	Country Code
54	<u>CZ</u> -ČDC	Roos	31 54 3525 000-8 to 299-6
		Rils-y	31 54 3538 001-9 to 100-9
		Laaps	31 54 4309 001-8 to 100-8
		Laaps-y	31 54 4309 101-6 to 200-6
56	<u>SK</u> -ZSSKC	Snps	31 56 472 3000-4 à 3199-4
		Sps	31 56 472 0401-7 à 0819-0
		Laas	31 56 471 7001-0 à 7071-3
			31 56 471 9001- 8 à 9100-8
			21 56 430 5000-2 à 5039-0
74	<u>S</u> -TWA	Laas	84 74 4308 200-7 to 204-9
80	<u>D</u> -TWA	Laas	24 80 4303 001-1 to 002-7
			24 80 4305 340-9 to 360-7
			24 80 4305 362-3 to 365-6
			24 80 4305 367-2 to 468-8
			24 80 4305 473-8
			24 80 4305 482-9
			24 80 4305 487-8 to 501-6
			24 80 4305 506-5
			24 80 4305 508-1
			24 80 4305 519-8
			24 80 4305 550-3 to 553-7
			24 80 4305 555-2
			24 80 4305 559-4 to 560-2
			24 80 4305 563-8 to 590-9
			24 80 4305 592-5 to 610-5
			24 80 4305 613-9 to 620-4
			24 80 4305 622-0 to 623-8
			24 80 4305 625-3 to 626-1
			24 80 4305 629-5 to 636-0
			24 80 4305 638-6 to 640-2
24 80 4305 644-4 to 615-9			
24 80 4305 653-5 to 656-8			
24 80 4305 658-4 to 659-2			
24 80 4305 661-8 to 663-4			
24 80 4305 665-9 to 678-2			

100.3

			<p>24 80 4305 680-8 to 689-9</p> <p>24 80 4305 692-3 to 693-1</p> <p>24 80 4305 695-6 to 697-2</p> <p>24 80 4305 699-8 to 702-0</p> <p>24 80 4305 704-6 to 705-3</p> <p>24 80 4305 707-9 to 742-6</p> <p>24 80 4305 744-2 to 757-4</p> <p>24 80 4305 760-8</p> <p>24 80 4305 763-2 to 771-5</p> <p>24 80 4305 773-1 to 776-4</p> <p>24 80 4305 778-0 to 786-3</p> <p>24 80 4305 788-9 to 791-3</p> <p>24 80 4305 793-9 to 799-6</p> <p>24 80 4305 905-9</p> <p>24 80 4305 935-6</p> <p>24 80 4305 942-2 to 943-0</p> <p>24 80 4305 947-1</p> <p>Snps 33 80 4725 100-8 to 119-8</p> <p>33 80 4725 141-2</p> <p>33 80 4724 259-5 to 285-0</p> <p>Sn-p-z 81 80 4723 000-3 to 199-3</p>
80	<u>D</u> -DB	<p>Snps</p> <p>Rnoos</p> <p>Rbns</p> <p>Rns-z</p> <p>Rbns</p> <p>Snps</p> <p>Sns</p>	<p>37 80 4724 001-5 to 155-9</p> <p>37 80 3521 001-2 to 250-5</p> <p>81 80 3507 000-7 to 151-8</p> <p>31 80 3991 000-1 to 399-7</p> <p>81 80 3507 500-6 to 899-2</p> <p>31 80 4723 000-4 to 4725 699-1</p> <p>81 80 4712 000-6 to 208-5</p>
81	<u>A</u> -ÖBB	<p>Rnooss-uz</p> <p>Rnoos-uz</p> <p>Rnoos-uz</p> <p>Rnooss-uz</p> <p>Rnoos-uz</p> <p>Ros</p> <p>Laaprs</p>	<p>31 81 3522 000-8 to 014-9</p> <p>31 81 3522 100-6 to 131-1</p> <p>31 81 3522 200-4 to 207-9</p> <p>31 81 3522 500-7 to 699-7</p> <p>31 81 3523 100-5 to 399-3</p> <p>31 81 3925 000-1 to 696-6</p> <p>21 81 4395 001-0 to 300-6</p>
85	<u>CH</u> -SBB C	<p>Snps</p>	<p>31 85 4723 000-9 to 199-9</p>

2;